

CRAFCOTM **INC**
AN **ERGON** COMPANY

SUPER SHOT 60 MELTER

SUPER SHOT 60 MELTER

This manual is furnished with each new CRAFCO™ **SUPER SHOT 60 MELTER**. The manual will help your machine operators learn to run the sealer properly and understand its mechanical functions for trouble-free operation.

Your CRAFCO™ **SUPER SHOT 60 MELTER** is designed to give excellent service and save maintenance expense. However, as with all specially engineered equipment, you can get best results at minimum costs if:

- a. You operate your machine as instructed in this manual, and
- b. Maintain your machine regularly as stated in this manual.

TABLE OF CONTENTS

Safety Precautions	3
Warranty	4
Warranty Claim Instructions	4
Specifications	5
Operating Instructions	6
Machine Start Up	7
Dispensing The Material	8
Inlet Filter / Strainer	8
Loading Machine	8
Shutdown And Clean-out Procedure	9
Storing Machine	9
Instructions For Ordering Parts	9
Electric Hose Care And Cautions	10
Hose Transport Instructions	10
Maintenance	
Maintenance Instructions	11
Maintenance Chart	12
Recommended Fluids And Lubricants	13
Warning For Heat Transfer Oil And All Oils	13
Material Pump Replacement	14
Trouble Shooting	
Wiring Schematic	15
How to Check Hose And Wand	16
Hose Trouble Shooting	17
Burner Schematic	18
Burner Trouble Shooting Guide	19
Hydraulic Schematic	20
Trouble Shooting Hydraulics	21
Parts	
SS 60 Parts Diagram	22
SS 60 Parts List	23
Tank Diagram	24
Tank Parts List	25
Control Box Assembly	26
Control Box Parts List	27
Power Pack Assembly	28
Power Pack Parts List	29
Hydraulic Valve Assembly	30
Pump / Agitator Assembly	31

SAFETY PRECAUTIONS

- * High operating temperatures of Sealant and Machine require protective clothing, hard soled shoes and heat resistant gloves be worn by operator.
- * Always wear eye protection.
- * Observe all **CAUTION AND WARNING** signs posted on machine.
- * Avoid the entrance of water into any part of the machine. Water will displace heat transfer oil or sealant which could be hazardous to personnel surrounding machine when it reaches operating temperature.
- * Avoid bodily contact with hot sealant material or heat transfer oil, serious burns may result.
- * Read Operator Manual thoroughly before operating machine.
- * Make sure operator is familiar with machine operation.
- * Shut down burner and engine prior to refilling LPG tanks.
- * When adding solid material to Sealant Tank, lift lid, place material onto lid and close lid. Hot material could splash and cause serious burns if this procedure is not followed.
- * Keep hands, feet and clothing away from all moving parts.
- * Always keep a fire extinguisher near the unit. Maintain extinguisher properly and be familiar with its use.
- * DO NOT exceed 525° F for heat transfer oil temperature.
- * DO NOT overfill heat transfer oil level. Expansion of oil during heat up could cause overflow. Check oil each day before starting burner, add oil to full mark on dipstick (at 70° F). Use only recommended heat transfer oil and change after 500 hours of operation or one year, whichever occurs first.
- * Follow operating instructions for starting and shut-down of burner. Instructions are mounted on control box.
- * Calibrate temperature control prior to initial operation and each 50 hours of operation.
- * Replace any hoses which show signs of wear, fraying, or splitting. Be sure all fittings and joints are tight and leak proof.
- * Precaution is the best insurance against accidents.
- * The melter should not be left unattended with the burner lit.
- * Tighten all bolts and screws after every 100 hours of operation.
- * CRAFTCO™, INC. assumes no Liability for an accident or injury incurred through improper use of the machine.

LIMITED WARRANTY

Crafco™, Inc., through its authorized distributor, will replace for the original purchaser free of charge any parts found upon examination by the factory at Chandler, Arizona, to be defective in material or workmanship. This warranty is for a period within 60 days of purchase date, but excludes engine or components, tires, and battery as these items are subject to warranties issued by their manufacturers.

After 60 days, Crafco™, Inc. warrants structural parts, excluding heating system, hydraulic components, material pump and hoses, hot oil pump, applicator valves, and electrical components for a period of (1) one year from date of delivery. Crafco™, Inc., shall not be liable for parts that have been damaged by accident, alteration, abuse, improper lubrication/maintenance, normal wear, or other cause beyond our control.

The warranty provided herein extends only to the repair and/or replacement of those components on the equipment covered above and does not cover **labor** costs. The warranty does not extend to incidental or consequential damages incurred as a result of any defect covered by this warranty.

All transportation and labor costs incurred by the purchaser in submitting or repairing covered components must be bore by the purchaser.

Crafco™, Inc., specifically disavows any other representation, warranty or liability related to the condition or use of the product.

Warning - Use of replacement parts other than genuine Crafco™ parts may impair the safety or reliability of your equipment and nullifies any warranty.

CRAFCO™ Inc. WARRANTY CLAIM INSTRUCTIONS

Please follow the instructions stated below when calling in a warranty claim. Failure to follow these procedures may be cause to void the warranty.

1. Call your local Crafco™ Distributor. If you do not know who your local distributor is, call a Crafco™ Customer Service Representative, (Toll Free 1-800-528-8242) for name, location and telephone number.
 2. On contacting the Distributor, be prepared to identify the machine type, model number and serial number, also the date of purchase if available.
 3. Should the cause of malfunction be a defective part, the Distributor will advise you of the procedure to follow for a replacement.
-
4. The warranty is valid only for parts which have been supplied or recommended by CRAFCO™ Inc.

If you have any additional questions regarding warranty repairs and parts, please do not hesitate to call toll free 1-800-528-8242.

CRAFCO™ INC.
235 S. HIBBERT DR.,
MESA, AZ 85210
(602)-655-8333
Toll Free 1-800-528-8242

SPECIFICATIONS

Vat Capacity	60 Gallons
Melt Capacity	40 Gallons/Hour
Heat Transfer Oil Required	21 Gallons at 70° F.
Tank Construction	Double Boiler Type
Tank Opening Size	12" X 15"
Maximum Heat Input	Vapor Burner 180,000 BTU's
Burner & Temperature Control	Automatic - Fail Safe
Engine - Kohler Model CH11 - Propane Fueled	Single Cylinder 11 BHP @ 3,600 rpm
Drive Mechanism	All Hydraulic with infinite speed on Mixer & Material Pump
Mixer	Full sweep mixer with 2 horizontal paddles
Axle	Single - 2,000 lb. Capacity
Tires (2)	20.5 X 8 X 10 - 4 ply rating (1,005 lb. capacity each)
Dry Weight	Approximately 1,500 lb.
Propane Bottle (1)	100 lb.
Generator	2,000 Watt - 12 Volt

SUPER SHOT 60 MELTER OPERATING INSTRUCTIONS

INTRODUCTION

The CRAFCO™ SUPER SHOT 60 Melter was developed to melt CRAFCO™ Brand Sealants. However, it will work equally well with all road asphalts and federal specification crack or joint sealants.

DO NOT operate machine without following these instructions:

- a. Fill propane tank.
- b. Check engine crankcase oil level (refer to Engine Operator's Manual).
- c. Check hydraulic fluid level, at ambient temperature. Add fluid if necessary to bring to correct level.
- d. Check heat transfer oil level. At 70° F., the oil should be at the full mark on the dipstick.

DO NOT overfill or spillage may occur when oil is heated and expands.

- e. All toggle switches should be turned "OFF" and both temperature control dials at minimum setting.
- f. Remember that safe operation of this equipment is the operator's responsibility.

CAUTION:

Extreme care must be used when operating this equipment. Safety is the result of being careful and paying attention to details. Remember the propane flame is about 2,200° F. Certain exposed parts of this machine, when operating, reach 500° F.; the sealant as high as 400° F. and the hydraulic fluid may reach 200° F. Always wear protective clothing, hard soled shoes, and eye protection. Be sure that all joints and fittings are tight and leak proof. Immediately replace any hose which shows any signs of wear, fraying, or splitting. Tighten all bolts on all flanges after 100 hours. Tighten all bolts, nuts, and screws every 250 hours.

MACHINE START UP

TO START BURNER

1. Open LPG tank valve.
2. Open Line Valve at Cylinder.
3. Start Engine Per Instruction Below.
4. Turn "ON" toggle switch at burner box. Follow directions on control box.
5. Set hot oil temperature at 500° F. and material temperature at manufacturers recommended temperature.
6. Turn on the hose controller when hot oil reaches approximately 300° F.

STARTING THE ENGINE

Depress the priming button on the SD zero flow regulator next to the LP bottle. Button should be depressed for approximately 2 seconds. Turn the ignition key to start position. Engine should start. If engine does not start, depress button again and try starting again. After engine starts, allow to warm up before using hydraulics or generator.

HEATED HOSE, WAND, AND CONTROLLER

NOTE!! The hose must be up to temperature before dispensing can take place. IMPORTANT!! DO NOT twist or kink hose. Avoid sharp bends and continuous twisting. Maintain minimum 10" bend radius. DO NOT exceed 400 degrees!! DO NOT move or bend hose when cold. Damage may result.

The heated hose supplied with the machine is Teflon lined with a stainless steel overbraid. It has a heating element which runs down the hose to heat the material within the hose. The hose is insulated with silicone foam rubber and is covered with a durable rubber outer covering. The wand has an aluminum tube to protect both the wand and the operator. The pistol grip actuator is equipped with an electric switch which when depressed sends a signal to actuate the pump. At the end of the wand, a high temperature elastomeric output valve is attached. The valve is pressure actuated and opens automatically when fluid pressure is applied. The wand is equipped with a trigger lock to prevent accidental pump actuation when not pumping material. The trigger should be in the "LOCKED" position at all times except when intentionally pumping material.

Turn the hose controller to the "ON" position. Adjust the temperature dial to approximately 400 degrees. The hose will come up to temperature in approximately 30 minutes. After the hose is hot, the light on top of the hose controller box will turn off and the temperature may be reduced to approximately 360 degrees. It is advisable to run the hose at the lowest temperature setting possible.

IT IS STRONGLY RECOMMENDED THAT THE HOSE BE STORED IN THE HOSE HANGER WHEN NOT IN USE OR WHEN IN TRANSIT. THIS WILL HELP PREVENT TWISTING OR KINKING.

STARTING THE MIXER

When the sealant material reaches a liquid state, engage the mixer by moving the toggle switch to "ON". If the mixer does not move, allow material to heat longer. Jamming of mixer shaft causes hydraulic oil to over heat and machine damage could occur. Remember, mixer does not start with melter lid open. Set the mixer speed using the flow control on hydraulic panel.

DISPENSING THE MATERIAL

NOTE: PROTECTIVE CLOTHING, GLOVES, HARD SOLED SHOES, AND FACE SHIELD OR SAFETY GLASSES SHOULD BE WORN WHEN OPERATING OR FILLING THIS EQUIPMENT. READ ENTIRE MANUAL BEFORE OPERATING.

When the material and the hose have reached proper application temperature, you are ready to dispense material. The wand is equipped with a disposable duckbill valve on the end which shuts off the flow of material when the pump is turned off and prevents excessive dripping of material. This valve also directs the material into a stream for easy application into the crack.

Some difficulty may be encountered when starting up on cold days. Although the wand is designed to heat the material all the way down to the tip, on cold days it may be necessary to place the tip of the wand inside the melting pot to facilitate material melting in the valve. Insert the wand tip in top of melter for a short time before proceeding.

You are now ready to dispense material. Turn the pump flow control to the lowest setting by turning the speed control knob fully counterclockwise. With the wand tip inserted into the top of the melter, depress trigger on the wand and slowly increase pump speed by turning the speed control knob clockwise until the pump motor starts to turn. Material should start to flow from the tip of the duckbill valve. Adjust the pump speed for the desired rate of flow for the application and dispense material as required. The rate of flow may be varied while the pump is running by rotating the speed control knob in a clockwise direction.

NEVER POINT WAND AT ANY PART OF THE BODY OR AT ANY OTHER PEOPLE. HOT MATERIALS CAN CAUSE SEVERE BURNS. WEAR PROTECTIVE EQUIPMENT WHEN FILLING OR OPERATING THE EQUIPMENT. READ MANUAL BEFORE OPERATING.

INLET FILTER/STRAINER

The melter is equipped with an inlet filter/material strainer at the material pump. This strainer is attached to mixer and rotates when the mixer is turning. The strainer keeps rocks and other foreign material from entering and plugging the hose or pump. No maintenance of this screen is required under normal operation.

LOADING MACHINE

When loading solid material into the sealant tank, the mixer will stop when the lid is lifted.

To load, lift the lid, place the material on the lid and close lid. Following this procedure will prevent the material from splashing and causing serious burns to personnel.

The solid materials must be added at intervals which will allow the mixer to rotate without jamming. If blocks of material are fed in too quickly, jamming will result and slow down the melting process.

SHUTDOWN AND CLEAN-OUT PROCEDURE

When shutting down the machine for the day, there are several schools of thought about how much material to leave in the machine. CrafcO™ recommends leaving the melter about half full. This will give a fairly rapid heat up rate in the morning, but will allow enough material to start dispensing right away when the material becomes molten.

1. Turn the gas ignition control toggle switch to "OFF".
2. Turn the hose controller to the "OFF" position.
3. Store hose in hose hanger. **Important!!! DO NOT** kink or twist hose as permanent damage will result.
4. Turn the mixer toggle switch to "OFF" position.
5. Turn the engine off at the engine key switch.
6. Turn LPG off at line valve and valve at LPG bottle.

STORING MACHINE

The melter should be stored in an area where moisture cannot enter machine heating system, such as hot oil, controls, etc. Extended down time can cause moisture build up in heating oil tank.

If there is any suspicion that moisture may have collected in heat transfer oil, warm heat transfer fluid to 300° F. for 2 to 3 hours to evaporate the moisture.

INSTRUCTIONS FOR ORDERING PARTS

Parts may be ordered from your local CRAFCO™ distributor or directly from CRAFCO™, Inc., if a distributor is not available in your area. When ordering parts, give the following information:

- a. Part Number
- b. Machine Model
- c. Serial Number from Name Plate

Write or telephone:

CRAFCO™, Inc.
235 S. HIBBERT DR.,
MESA, AZ 85210
Phone: (602)-655-8333
Toll Free: 1-800-528-8242

ELECTRIC HOSE CARE AND CAUTIONS

Twisting and kinking of the electric hose (used on LF, BAX, SS60 and SS125 Melters) is the number one cause of hose failure.

When this happens, the electric heating wires are shorted out to the metal hose cover and the hose stops heating.

This type of failure is not covered under the CRAFCO™ warranty.

To help prevent twisting, kinking and the resulting hose damage, the operator should:

- a. Do not move or use hose unless it has been turned on at least 35 minutes and set at a minimum temperature of 300° F.
- b. Make sure hose swivel between hose and wand moves freely.
- c. Limit the hose bending to a radius of 10 inches.
- d. Avoid bending the hose over sharp edges such as the edge of the frame or tank.
- e. Avoid twisting.
- f. Do not exceed 400° F on the hose controller or material temperature.
- g. Follow all instructions of the melter as well as those in the instruction manual.
- h. Avoid pulling hose beyond it's limits.

HOSE TRANSPORT INSTRUCTIONS

1. Remove hose from jib support and rotate jib support towards front of machine until it locks into position.
2. Wrap hose on hose hanger two complete wraps (Approximately 20 inch diameter).
3. Store wand in support hook.

CAUTION:

Hose damage will occur if:

- a. Hose is bent or moved when cold.
- b. Hose is twisted or bent at less than 10 inch radius.
- c. Hose is moved prior to being turned on at least 35 minutes and set at 380 degrees F.
- d. Operator crosses over or under hose causing hose to twist or wires between hose and wand connection to twist or wrap up.
- e. Swivel is cold and not free to move allowing hose to twist.
- f. Hose to wand wiring is pulled, stressed, or used to support the wand.

MAINTENANCE INSTRUCTIONS

ENGINE:

Check oil every 8 hours of operation. Change after the first 5 hours of operation and change every 25 hours thereafter.

See engine owners manual for additional operating and maintenance instructions.

HYDRAULIC SYSTEM:

Check hydraulic fluid every 8 hours. Change hydraulic filter after first 10 hours of operating and every 250 hours thereafter. Change hydraulic fluid every 500 hours of operation.

WHEEL BEARINGS:

Re-pack wheel bearings every 24,000 miles or every two years, using a good grade of bearing grease.

TONGUE JACK:

Lubricate tongue jack, using a good grade of bearing grease.

SERVICE INSTRUCTIONS

1. Conduct a general inspection of your machine at least once a week. Replace all worn or damaged parts, make any necessary adjustments and tighten all loose nuts or screws.
2. Keep regular replacement items in stock for emergency repairs, to avoid costly "down" time.
3. Watch for leaks. Tighten fitting or repair as necessary.
4. Clean machine externally periodically. Check with sealant manufacturer for recommendation.
5. Follow recommended maintenance procedures on maintenance chart.

MAINTENANCE CHART

LOCATION	PROCEDURE	HOURS			
		8	50	100	500
Engine check oil level.	See engine instruction manual.	*			
Other engine maintenance	See engine operating and maintenance instructions				
Battery	Check water level weekly				
Heat transfer oil	Check	*			
	Change		*		
Hydraulic oil filter	First change (10 hours)				
	Subsequent changes (250 hours)				
Hydraulic oil	Check oil	*			
	Change oil				*
	For proper oil, see recommended fluids & lubricants, below.				
Wheel bearings	Clean & re-pack using a good grade of bearing grease	Every 24,000 miles or every two years			
Tongue jack	Grease, using good grade of bearing grease.	Once a year			

RECOMMENDED FLUIDS AND LUBRICANTS

APPLICATION	RECOMMENDED	FULL POINT
Engine oil	Refer to Kohler owners manual	2 Qts.
LPG	Propane	100 Lbs.
Hydraulic oil	Rondo oil - HD - 68 Texaco	10 Gal.
Heat transfer oil	Regal R&O 68	21 gal.

The following is a list of suitable Heat Transfer Oils to be used in CrafcO equipment.

PRODUCER	PRODUCT NAME	PRODUCT NO.
Texaco	Regal	R & O 68
Exxon	Caloria	HT 43
Arco	Rubilene	-
Citgo	Sentry	R&O 68
Gulf Oil Co.	Security	R&O 68
Shell Oil Co.	Therma	C
Chevron Oil Co.	Chevron Heat Transfer Oil	-
Conoco	Heat Transfer Oil	R&O 68

WARNING

The Heat Transfer Oil in this machine is a grade that has been tested and recommended by CrafcO™, Inc. The addition of any grade of oil not specifically recommended by CrafcO™, Inc., shall be cause for voidance of all warranties.

All oils subjected to high temperatures deteriorate with time and lose many of their characteristics. Tests conducted by CrafcO™, Inc. have determined that for best results and safety, the Heat Transfer Oil in this machine must be drained and replaced with CrafcO™, Inc. recommended oil after five hundred (500) hours of operation or one (1) year, whichever occurs first.

SUPER SHOT PUMP REPLACEMENT

Step 1

Bring melter up to temperature as preparation for draining the material tank. Remove pipe cap located at rear of machine and drain tank (**CAUTION!!! EXTREMELY HOT MATERIAL**).

Step 2

Remove both guards from the motor mount bridge for access to chain and sprockets.

Step 3

Rotate agitator until connecting link is accessible. Disassemble the connecting link and remove the drive chain.

Step 4

Loosen the set screw in the lower coupling half between the hydraulic motor and the drive shaft.

Step 5

Remove the (4) hydraulic hoses and cap off all ports. **Note:** Mark hoses for ease of replacement.

Step 6

Remove the (4) bolts holding motor mount bridge to top of melter. Lift off motor mounting bridge and set aside.

Step 7

Remove (2) bolts holding agitator shaft bearing. **Note:** Do not remove bearing from agitator shaft.

Step 8

When unit has cooled sufficiently, Remove (6) bolts holding paddles to top of screen. Remove paddles from tank.

Step 9

Remove pump drive shaft from center of agitator shaft then lift agitator shaft and screen assembly as high as possible and insert screw driver into shaft hole (**NOTE: There is a key in the pump drive shaft**). This will support this assembly while removing the pump from the tank.

Step 10

Remove the (6) bolts which fasten the pump to the tank. Lift the pump from the material tank (**CAUTION !!! THE PUMP WEIGHS APPROXIMATELY 90 Lbs.**).

Disassembly of material pump

Step 11

Remove the (2) bolts which hold the pump plates together. Disassemble the (3) plates from each other (**Note: as pump is being disassembled make note of the orientation of holes in each plate**).

Step 12

Clean all pump parts thoroughly before beginning to reassemble the pump.

Step 13

Assemble the pump, check for free movement of the pump gears. If gears do not turn freely, loosen bolts slightly and align plates until the gears turn freely. Torque all the bolts to 35 Ft. Lbs.

Step 14

Install all parts in machine starting from **Step 10** and working backwards to **Step 1**.

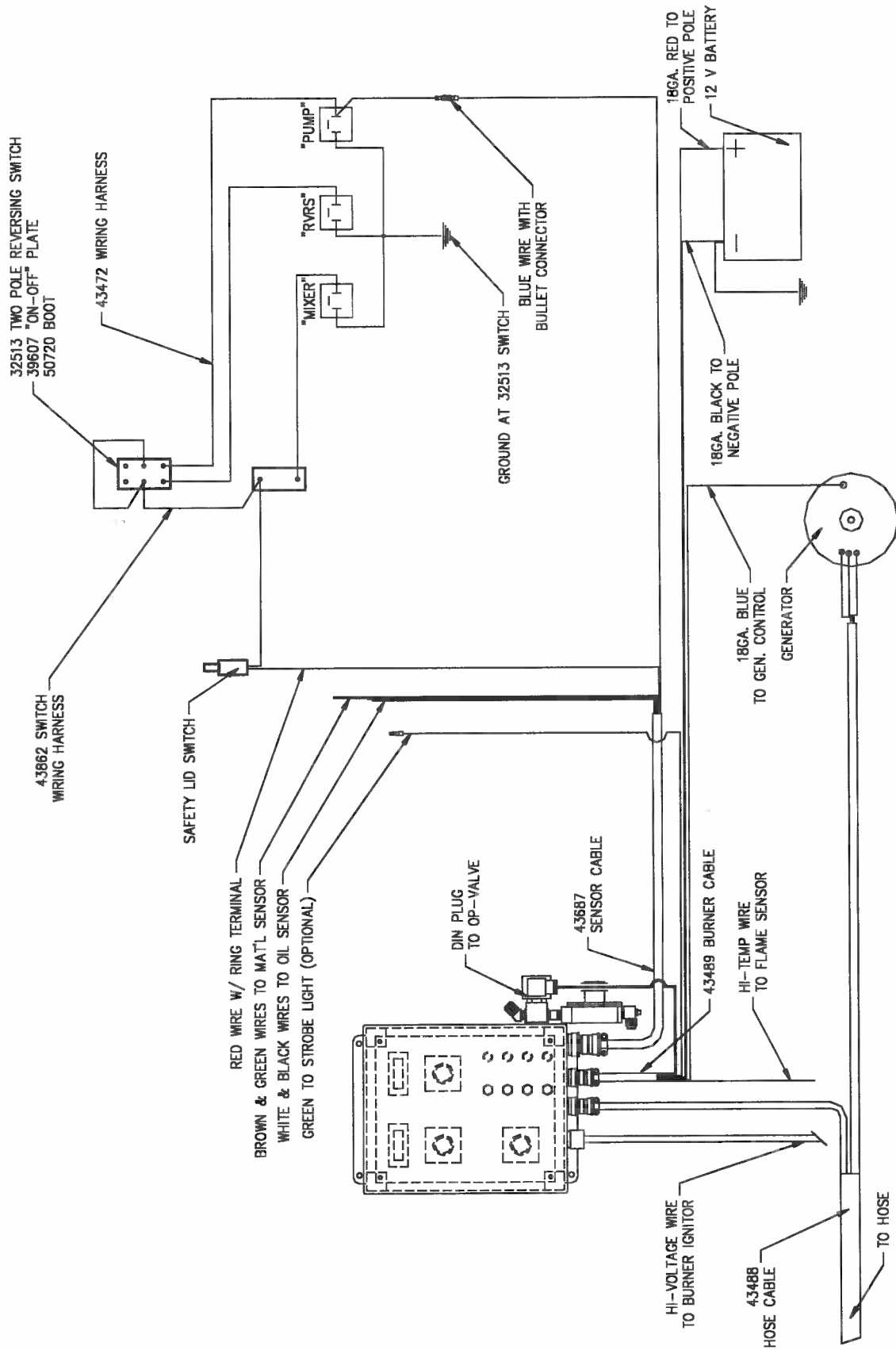

HOW TO CHECK SS125 AND SS60 HOSE AND WAND

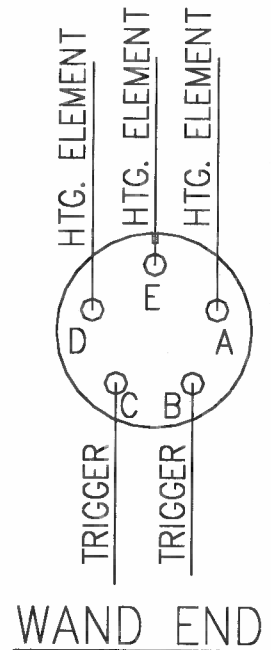
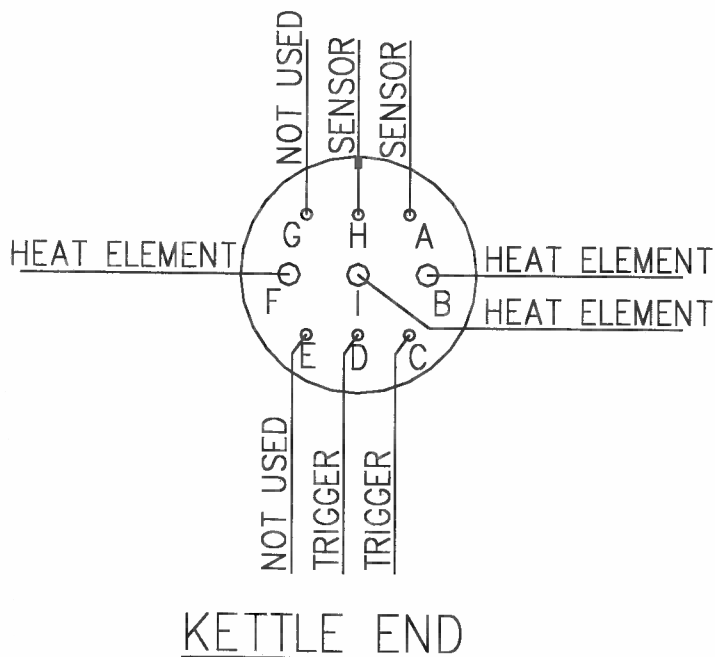

1. If hose is not heating, check continuity between "F", "I" and "B" while wand is connected. Also check for continuity to the case. There should not be any continuity to the case.
 2. If there is no continuity in one of the ports, disconnect wand and check "A", "E" and "D" on wand connector, then check "A", "E" and "D" to "F", "I" and "B" on ends of hose.
 3. If all of the above checks OK, then check the resistance of the sensors between "A" and "H" on kettle end of the hose, it should read 1.01 Kohms. If there is no resistance then the sensor is bad. **NOTE! : The resistance will be higher if the hose is warmer than 70 degrees.**
 4. If trigger is not working, check continuity between "D" and "C" (kettle end) when trigger is pulled. If no continuity disconnect wand and check "C" and "B" (wand). If there is no continuity then switch is bad.
 5. If there is continuity, then disconnect the second cable from the right and check "A" on the control box to see if you have 12 volts going to the coil on the hydraulic valve.
-
6. **NOTE:** The electrical plugs on the hydraulic valves have a light which tells you if there is 12 volts to the coil. There is also a light on the driver card inside the control box which tells when there is 12 volts going to the card (SS125 ONLY).

HOSE TROUBLE SHOOTING

PROBLEM	CAUSE	REMEDY
Hose does not heat	Generator wire loose.	Tighten nut.
	Generator belt loose.	Tighten belt.
	Bad connection at control box.	Tighten plug.
	Bad connection between hose and wand.	Tighten plug.
	Hose kinked and shorted wires.	Replace hose.
	Generator not producing voltage.	Replace generator.
	Bad sensor in hose.	Send to Crafcro for repair.
	Hose heats partially	Hose kinked and wires shorted.
Hose light flickers	Bad Pak-Stat (Temp. Controller)	Replace Pak-Stat
Hose does not pump	Bad wire connection.	Repair loose wire.
	Bad switch	Replace switch.
	Cartridge failure on hydraulic valve.	Replace cartridge on valve.
	Coil failure on hydraulic valve.	Replace coil on valve.
	Driver card not set properly.	Set driver card.
	LED Readout is incorrect	Open circuit on the sensor
Short in the sensor		Replace bad wire.
Sensor resistance below 1000 ohms.		Replace sensor.
Polarity of plug to Pak-Stat		Check for P1 to 1 connection.

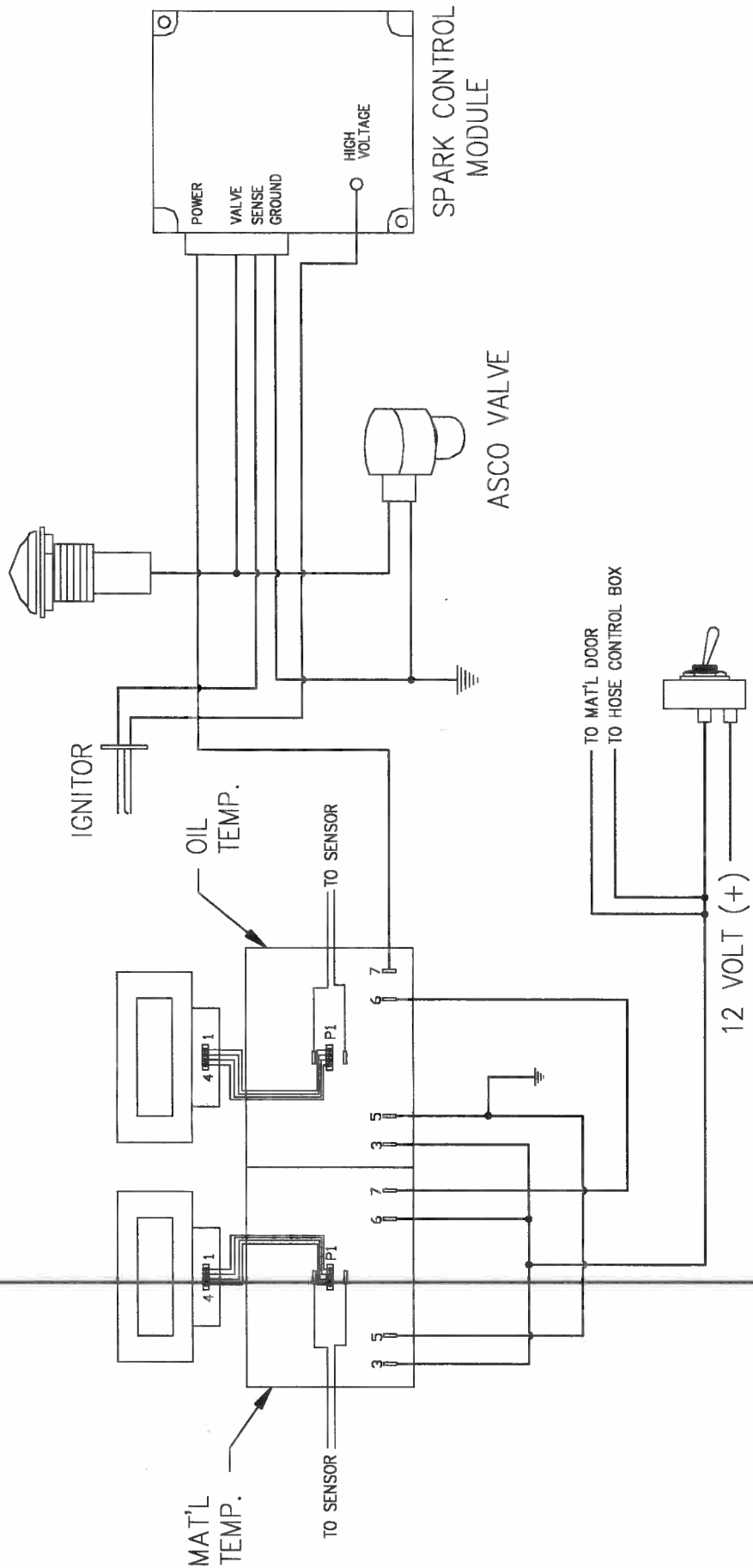

BURNER TROUBLE SHOOTING GUIDE

BURNER WILL NOT IGNITE:

Step 1: Check for 12 volts at toggle switch.

No, Then toggle switch is "Off"
Fuse is "Blown"
Broken wire

Yes, Then go to Step 2

Step 2: Check for 12 volts at terminal # 7 on material temperature thermostat.

No, Then material temperature thermostat is bad

Yes, Then go to Step 3

Step 3: Check for 12 volts at terminal # 7 on oil temperature thermostat.

No, Then oil temperature thermostat is bad

Yes, Then go to Step 4

Step 4: Check for 12 volts at power terminal of spark control module.

No, Then there is a bad connection or a broken wire

Yes, Then there is a Faulty spark control module
Faulty ignitor or ignitor wire
Reposition ignitor
Check for clogged burner orifice
Inadequate gas flow / or pressure
Faulty "ASCO" gas valve

BURNER LIGHTS BUT SHUTS DOWN IN 3.5 SECONDS:

Faulty ignitor
Broken or loose flame sensor wire
Faulty spark control module

BURNER LIGHTS BUT WILL NOT RE-LIGHT:

Calibrate thermostat
Blown fuse
Faulty spark control module
Faulty sensor

BURNER WILL NOT SHUT OFF @ TEMPERATURE SETTING:

Calibrate thermostat
Dirt in "ASCO" valve
Faulty sensors

PUMP/AGITATOR ASSY.- 43427

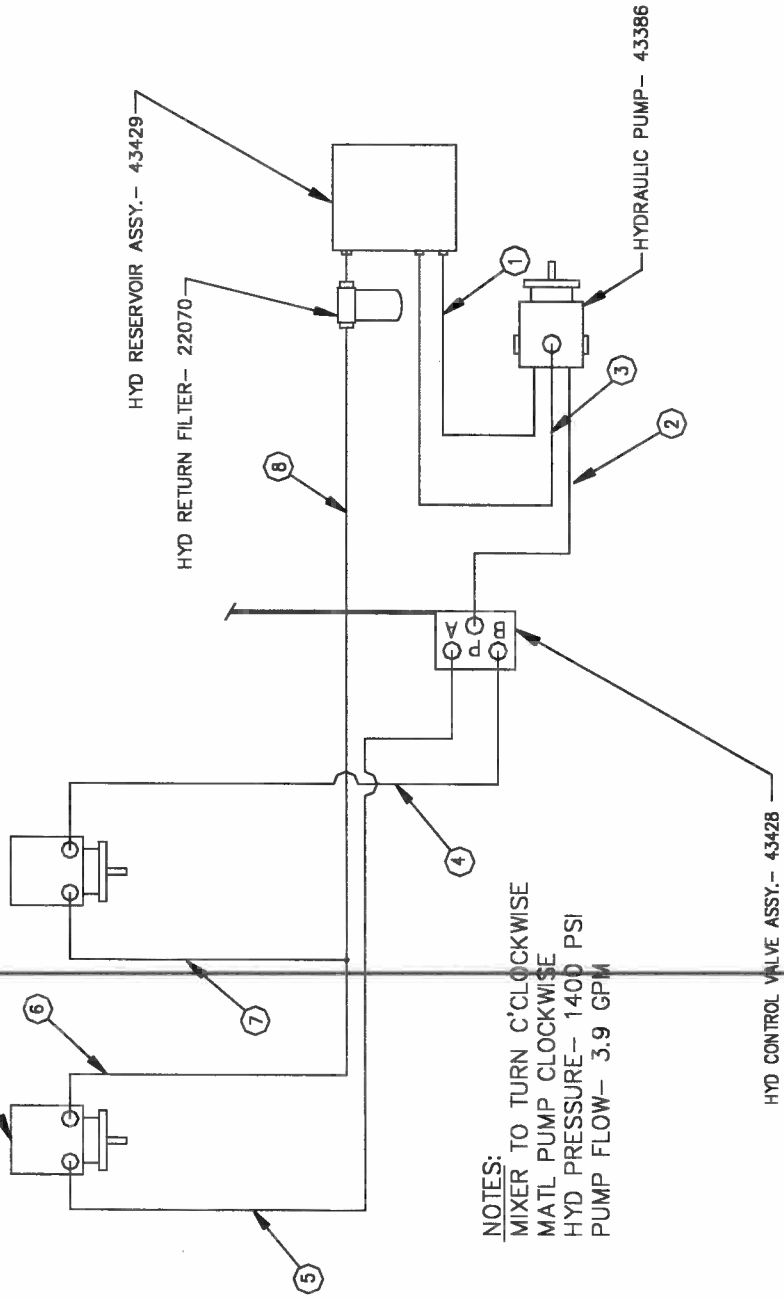

NOTES:
 MIXER TO TURN C'CLOCKWISE
 MATL PUMP CLOCKWISE
 HYD PRESSURE- 1400 PSI
 PUMP FLOW- 3.9 GPM

① HYD. RESERVOIR TO HYD. PUMP (SUCTION)
 1 29512 HYD HOSE ASSY 3/4 X 24" LG

② HYD. PUMP TO CONTROL VALVE
 1 29513 HYD HOSE ASSY, 3/8 X 57" LG

③ HYD. PUMP CASE DRAIN TO RESERVOIR
 1 40187 HYD. HOSE ASSY, 3/8 X 18" LG.

④ HYD VALVE TO MIXER HYD MOTOR
 1 40187 HYD HOSE ASSY, 3/8 X 18" LG.

⑤ HYD VALVE TO MATERIAL PUMP HYD MOTOR
 1 40012 HYD. HOSE ASSY, 3/8 X 24" LG.

⑥ HYD MOTOR (MATERIAL PUMP) TO BULKHEAD
 1 40012 HYD HOSE ASSY, 3/8 X 24" LG.

⑦ HYD MOTOR (MIXER) TO BULKHEAD
 1 29597 HYD. HOSE ASSY, 3/8 X 12" LG.
 1 29880 3/8 90° SWIVEL ADAPTOR

⑧ "T" PORT TO HYD RETURN FILTER
 1 29889 3/8 TUBE BULKHD RUN TEE
 1 29890 3/8 BULKHD NUT
 1 29880 3/8 SWIVEL ELBOW
 1 29535 HYD HOSE ASSY 3/8 X 26" LG

TROUBLE SHOOTING HYDRAULICS

PROBLEM	CAUSE	REMEDY
Mixer will not rotate	Sealant temperature too low. Too many blocks placed at one time. Inadequate hydraulic flow/pressure. Toggle switch turned off.	Continue to heat material. Continue to heat material Check hydraulic fluid level. Reset pressure, check flow if necessary.
Material pump will not turn.	Material in tank not to operating temperature. Inadequate hydraulic flow/pressure. Material pump damaged or foreign object lodged in pump.	Continue heating material. Check hydraulic fluid level. Reset pressure, check flow as necessary. Remove and replace.
When applying sealant it stops flowing from applicator wand.	Tank fluid level to low for material to flow into pump	Add more material or heating material until more liquid material is available.
Pump rotates, but will pump material.	Material cold, inlet still solid Hose not to temperature. Temperature at wand tip is inadequate.	Continue to heat material. Allow to heat longer. Set wand tip inside material tank.
Pump does not rotate	Bad wire connection. Bad switch at wand handle. Hydraulic cartridge failure. Hydraulic coil failure.	Find and repair. Remove and replace Remove and replace Remove and replace
Slow heat up of sealant	Build up of coked material on inside of material tank. Burner not operating / low LPG pressure Low heating oil level. Low heating oil temperature	Allow machine to cool. Remove deposits and flush with solvent. Repair / Adjust Make sure fluid level is Set at recommended temperature.

PARTS NOT SHOWN

50597 () HEATED HOSE - 15 FT.
50814 () HEATED WAND - 42"

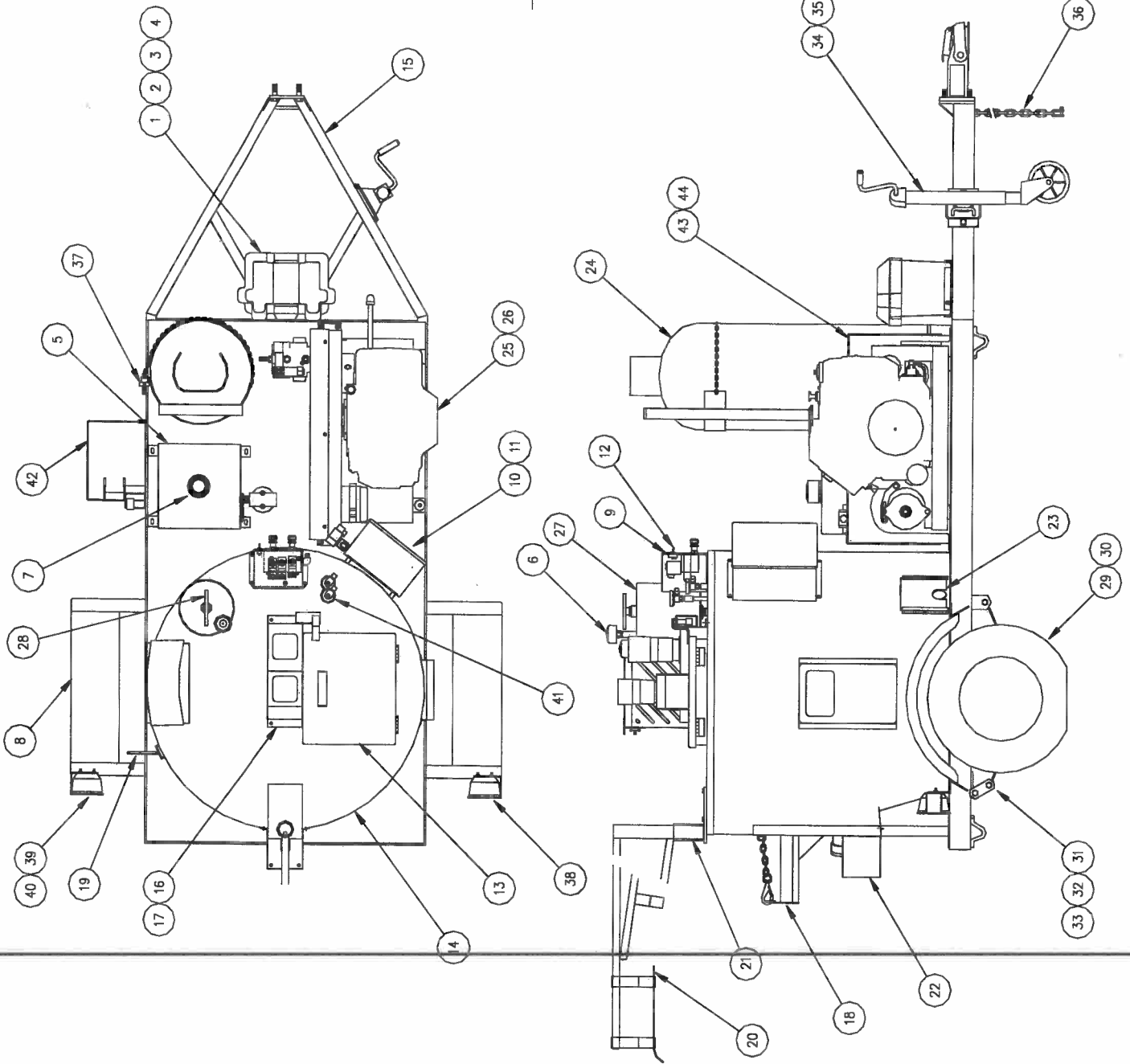

SS60 MELTER ASSEMBLY

NUMBER	PART NUMBER	DESCRIPTION	QTY.
1	24000	Battery Box	1
2	24002	12 Volt Battery	1
3	37038	Battery Cable (-)	1
4	29396	Battery Cable (+)	1
5	41520	Hydraulic Tank Assembly	1
6	26025	Air Breather	1
7	43424	Filler / Breather W/ Dipstick	1
8	40120	Fender Assembly	2
9	43367	Mounting Bracket - Hydraulic Valve	1
10	43389	Control Box Assembly	1
11	50074	Mounting Spacer	4
12	39608	Switch - Agitator	1
13	43338	Lid Assembly	1
14	43314	Modified Top cover	1
15	43301	Frame Assembly	1
16	43427	Pump / Agitator Motor Assembly	1
17	43307	Chain Guard	2
18	43477	Hose Hanger	1
19	43368	Wand Bracket	1
20	43828	Hose Boom	1
21	43836	Boom Mounting Base	1
22	43821	Heat Guard	1
23	43333	Burner Door	1
24	25118	LPG Bottle	1
25	43490	Power Pack Complete	1
26	41636	Isomount	4
27	43355	Overflow Tank	1
28	43374	Dipstick - Overflow Tank	1
29	40100	Axle Assembly With Springs	1
30	40873	Tire Assembly With Rim	2
31	23100	Bolt for Axle	6
32	23105	Locking Nut	6
33	23075	Pivot Link	2
34	40105	Swivel Jack	1
35	40106	Jack Bracket	1
36	40121	Safety Chain	2
37	26032	Black Knob	1
38	24022	RH Tail Light	1
39	24023	LH Tail Light	1
40	26099	License Plate Bracket	1
41	43465	RTD Sensor	2
42	43456	Drip Pan	1
43	39608	Switch - Lid	1
44	43473	Hydraulic Valve Assembly	1
45	32513	Switch, Momentary - Reverse	1

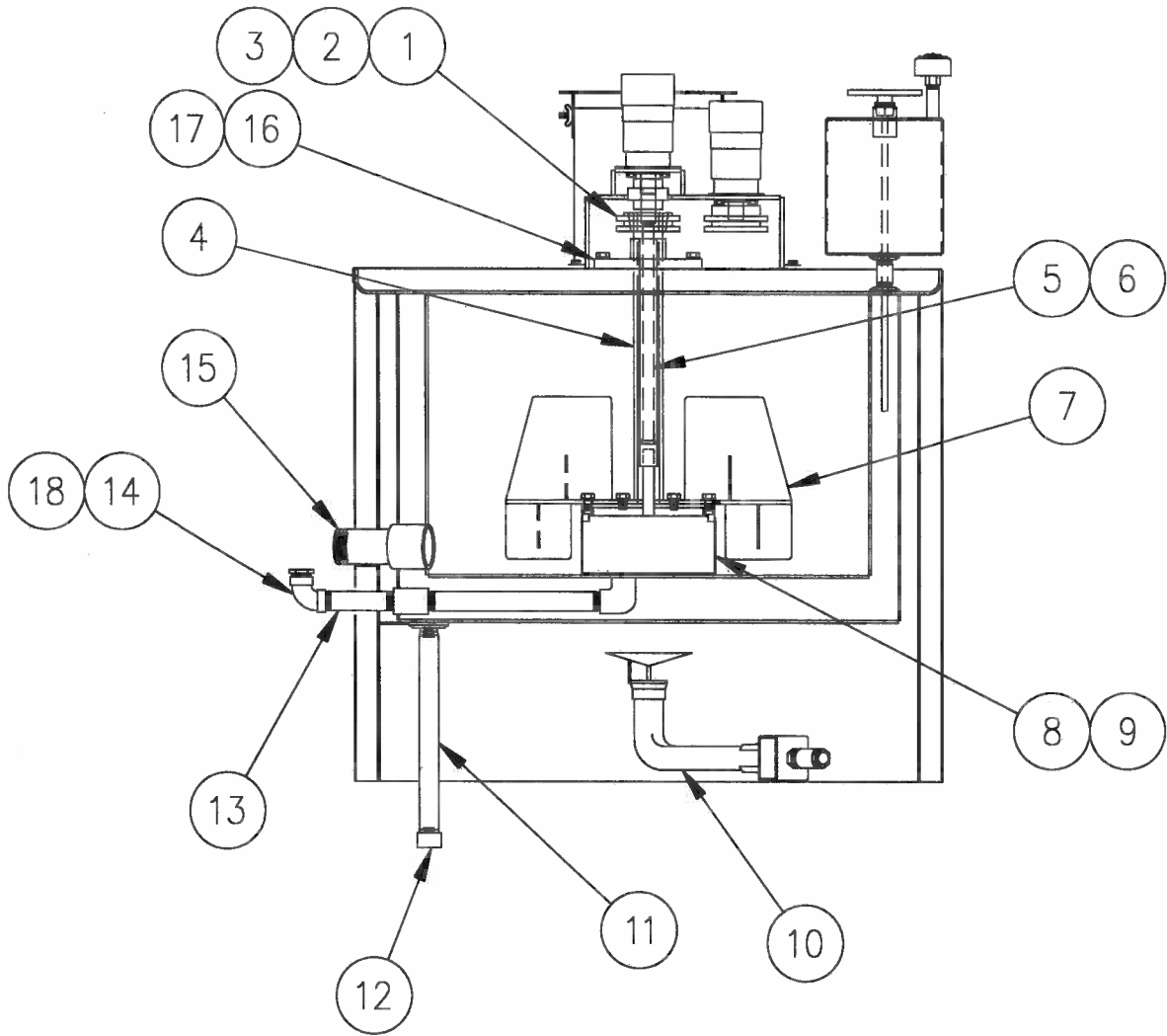

TANK DETAIL

NUMBER	PART NUMBER	DESCRIPTION	QTY.
1	43322	Sprocket - Driven	1
2	43321	Chain - Drive	1
3	43322	Connecting Link - Chain	1
4	43340	Mixer Shaft	1
5	43324	Drive Shaft - Pump	1
6	40084	Key, 3/16 Sq. x 7/8 Lg.	1
7	43325	Paddle Assembly	2
8	43426	Pump Assembly	2
9	43335	Strainer Assembly	1
10	43299	Burner Assembly	1
11	28174	1" x 15" Lg. Pipe Nipple	1
12	28270	1" Pipe Cap	1
13	28039	1" x 4" Lg. Pipe Nipple	1
14	28210	1" X 90 Deg. Elbow	1
15	28060	2" x 5" Lg. Pipe Nipple	1
16	50012	Bearing 2" Flanged	1
17	28273	Bearing 2" Flanged	1
18	28351	1" X 3/4" Reducing Bushing	1

- WIRE LEGEND
 RED-RED - MAIN POWER SUPPLY
 BLK-BLACK - GROUND
 GRN-GREEN - IGNITION CONTROL
 ORN-ORANGE - POWER TO OIL/MAT'L CONTRLR. & MIXER.
 PRP-PURPLE - POWER TO HOSE CONTRLR. & PUMP TRIGGER.
 BRN-BROWN - VALVE CONTROL
 GRN-GREEN - BEACON
 BLU-BLUE - GENERATOR CONTROL
 WHT-WHITE - FLAME SENSOR
 WHT/BLK-WHITE/BLACK - MAT'L SENSOR
 WHT/YEL-WHITE/YELLOW - OIL SENSOR
 WHT/RED-WHITE/RED - HOSE SENSOR

1. SOLDER WIRE ENDS PRIOR CRIMPING.
2. USE TEFLON PIPE SEALANT ON PIPE CONNECTIONS.
3. USE:
 - 24232 (34) SPADE TERMINALS ON WIRES ATTACHED TO TERMINAL STRIP.
 - 24231 (18) 1/4" TAB CONNECTORS ON WIRES ATTACHED TO TEMP. CONTROLLERS AND SWITCHES.
 - 24230 (6) 3/16" TAB CONNECTORS ON WIRES ATTACHED TO SENSOR TABS ON TEMP. CONTROLLERS.
 - 24097 (50) 1/8" HEAT SHRINK TUBE AROUND 24230, 24231, AND 24232 (.75 LONG EA.).
4. SOLDER LAMP WIRES TO CABLE WIRES AND INSULATE WITH HEAT SHRINK TUBE.
5. ALL WIRES TO 18 GA. 19 STRAND LIFE WIRE.
6. BRAID WIRES WITH 24260 (20) WIRE TIES.
7. SECURE WIRES TO PANELS WITH 33459 (8) WIRE CLIPS.

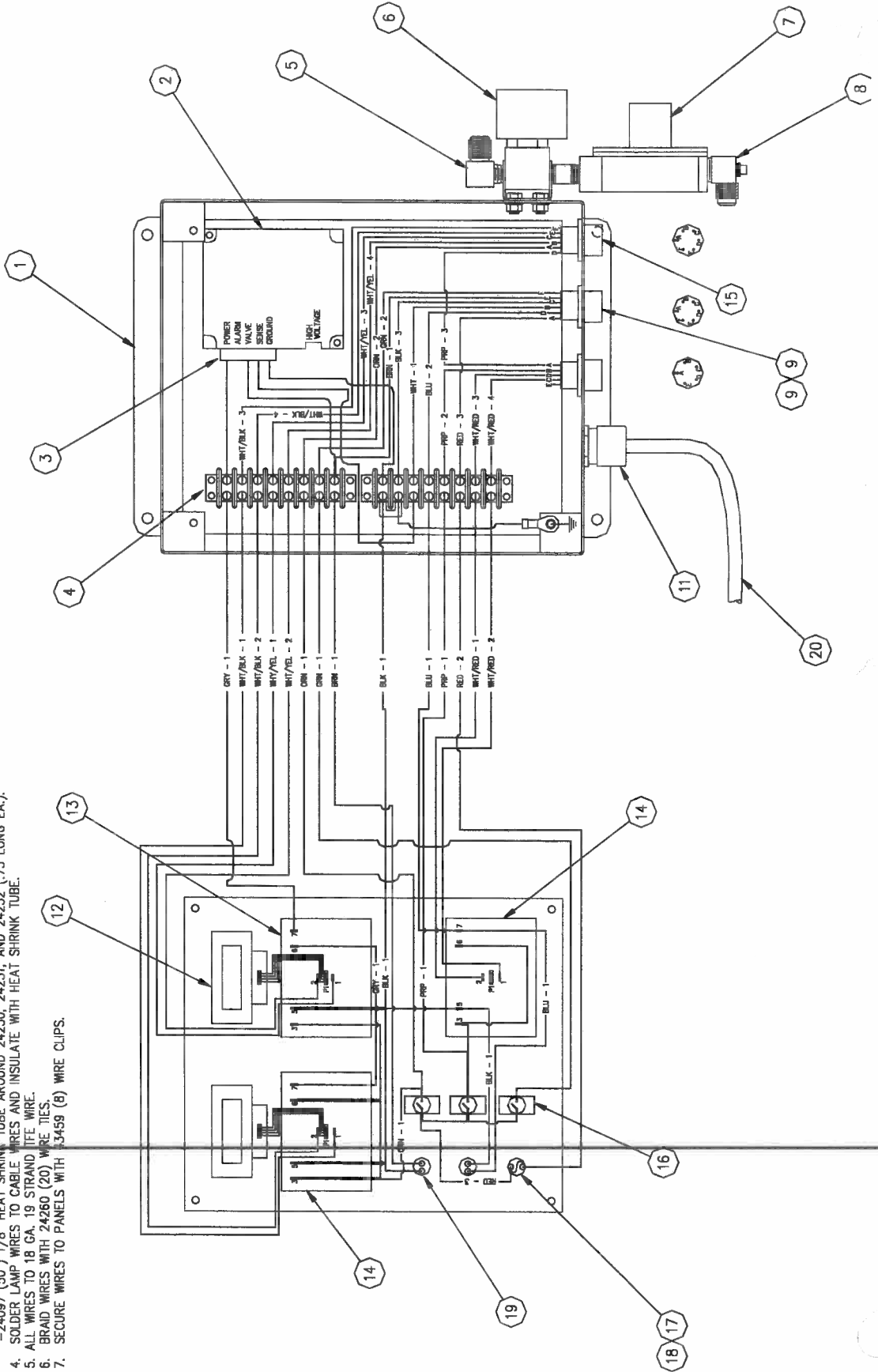

CONTROL BOX ASSEMBLY

NUMBER	PART NUMBER	DESCRIPTION	QTY. REQ'D
1	43665	Enclosure rework	1
2	25278	Spark control module	1
3	50559	Wiring harness	1
4	50250	Terminal strip	2
5	29871	Elbow 90 degree	1
6	25236	Gas valve	1
7	25087	Gas regulator	1
8	43441	Test port elbow	1
9	50215	Receptacle 5 - pin	2
10	50344	Gasket	3
11	51064	Cord grip	1
12	50251	Digital readout	2
13	43391	Pacstat controller (150-550)	1
14	43397	Pacstat controller (200-400)	2
15	50517	Receptacle 6 - pin	1
16	50719	Toggle switch	2
17	24185	Fuse holder	1
18	24199	Fuse 5 AMP	1
19	50226	Indicator lamp	2
20	50438	Hi - voltage cable assembly	1

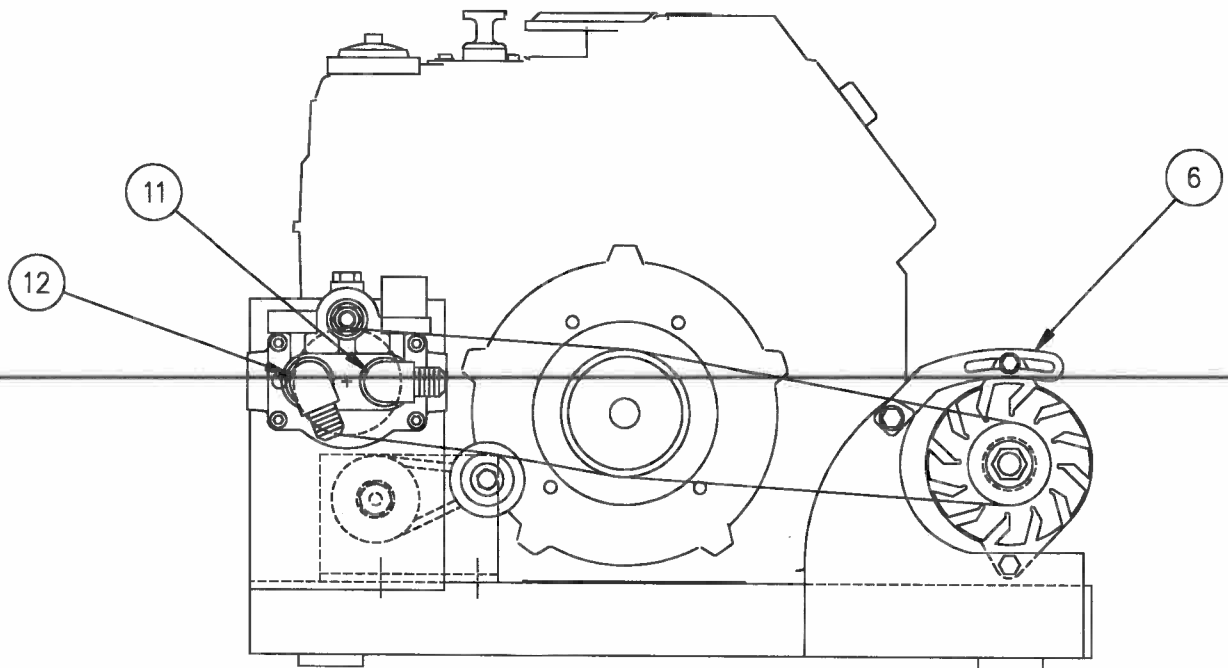
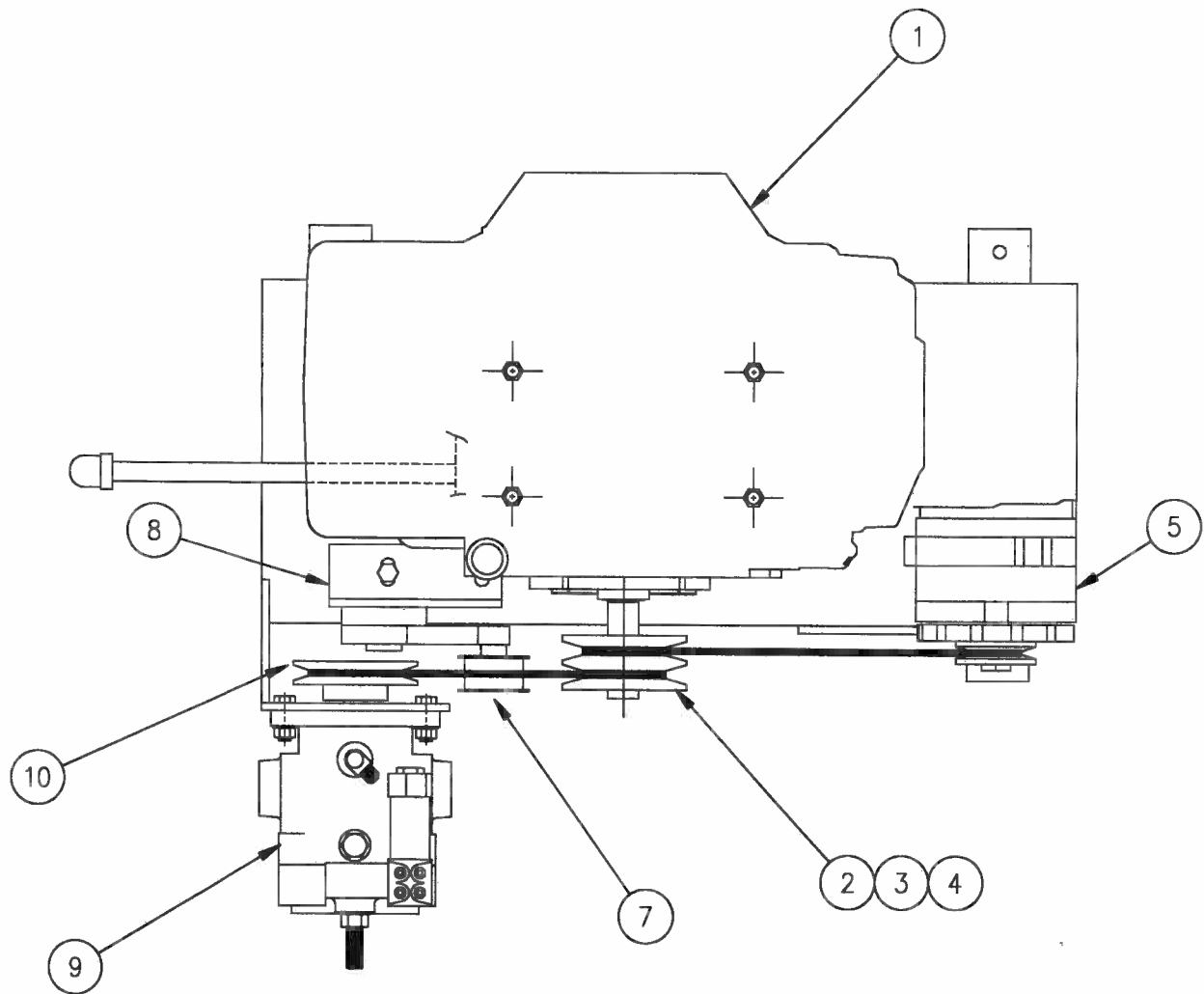

POWER - PACK ASSEMBLY

NUMBER	PART NUMBER	DESCRIPTION	QTY.
1	43480	11 HP Engine	1
2	50084	Pulley - Drive	1
3	50066	Taper Lock Bushing - Pulley	1
4	27017	Key - Shaft	1
5	43612	Generator, 12 VAC	1
6	43481	Adjustment Bracket	1
7	50085	Idler / Tensioner	1
8	43499	Idler Bracket	1
9	43386	Hydraulic Pump	1
10	43376	Pulley - Driven	1
11	29917	O-ring Adaptor	1
12	29916	O-ring Adaptor	1

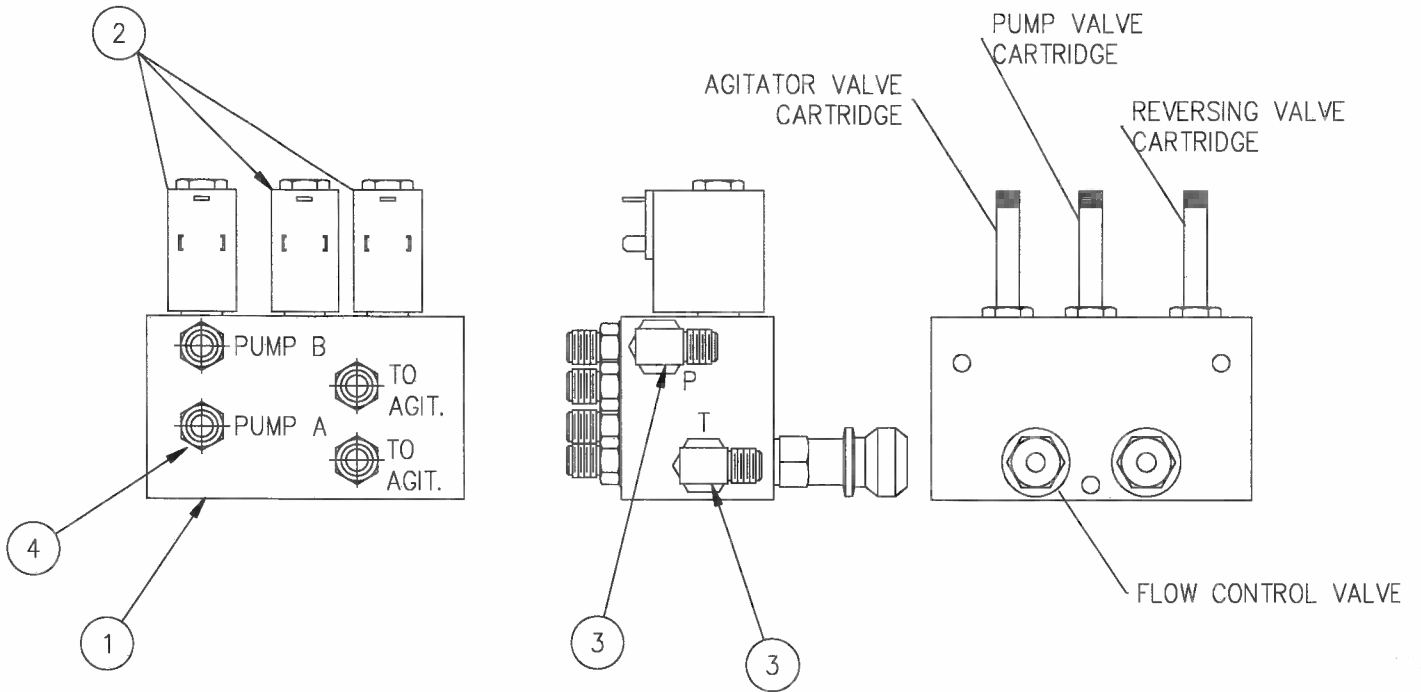

HYDRAULIC VALVE ASSEMBLY

NUMBER	PART NUMBER	DESCRIPTION	QTY.
1	43498	Hydraulic Valve Assembly	1
2	43853	Coil - Control Valve	1
3	40309	Elbow Adaptor	2
4	40311	Straight O-Ring Adaptor	4

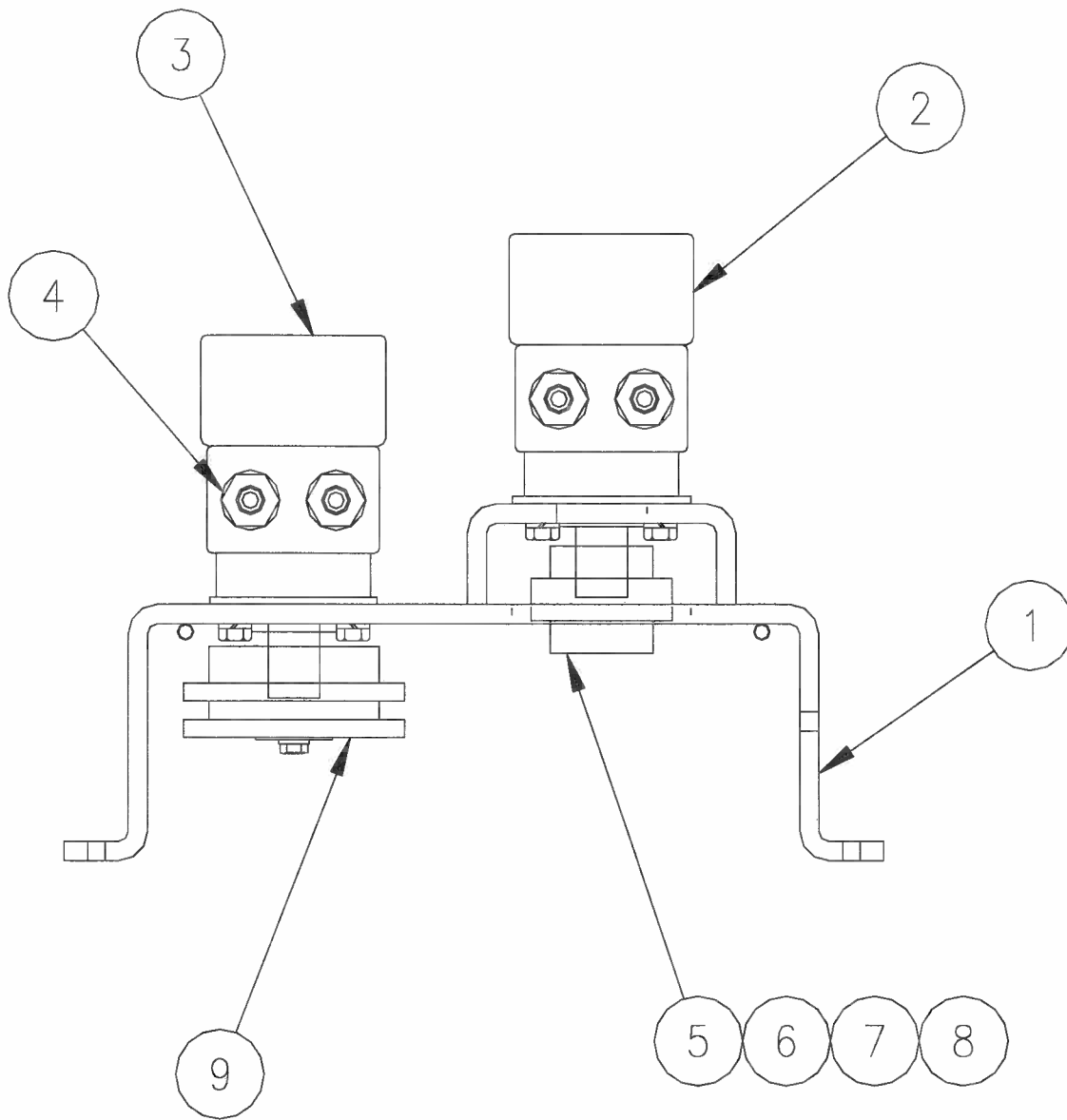

PUMP/AGITATOR ASSEMBLY

NUMBER	PART NUMBER	DESCRIPTION	QTY.
1	43345	Motor Mounting Bracket	1
2	43388	Hydraulic Motor - Pump	1
3	22027	Hydraulic Motor - Agitator	1
4	29828	Elbow O-Ring Adaptor	4
5	26002	Sprocket - Chain Coupling	2
6	26016	Chain - Coupling	1
7	26030	Connecting Link - Chain	1
8	31368	Key 1/4 x 1/4 x 7/8	1
9	43323	Sprocket - Agitator Drive	1

2

3

4



**Pioneering Leadership and Innovation in
Quality Pavement Maintenance Materials.**

CRAFCOTM INC
AN **ERGON** COMPANY

6975 W. Crafcow Way • Chandler, Arizona 85226
(602) 276-0406 • Wats 1 (800) 528-8242
FAX (602) 96100513

©Copyright 1988 by Crafcow Inc.