



E-Z PAINT MIXER
Operator/Parts Manual – 49110N
Revision A

Fill in appropriate fields that apply to this machine

Machine S/N: _____

Engine S/N: _____



**E-Z PAINT MIXER
P/N 4900N**

Table of Contents

1.0 About This Manual	1-1
1.1 How to use this manual:	1-1
2.0 Safety Precautions	2-1
2.1 General Safety	2-1
2.2 Personal Safety	2-1
2.3 Equipment or Operational Safety	2-1
2.4 California Proposition 65	2-2
2.4.1 All Crafco Inc. Equipment	2-2
2.4.2 All Crafco Inc. Equipment using a gasoline engine	2-2
2.5 Safety Symbols and Notices	2-3
3.0 Limited Warranty	3-1
3.1 Warranty Claim Instructions	3-2
4.0 Machine Specifications	4-1
5.0 Operating Instructions	5-1
5.1 Preparing the Machine for Start Up	5-1
5.2 Machine Start Up	5-2
5.3 Loading Material	5-3
5.4 Mixer Operation	5-4
5.5 Pouring Material	5-4
5.6 Operating the Drive Wheel	5-4
5.7 Shutting Down the Machine	5-5
5.8 Using the Hydraulic Tongue Jack	5-6
6.0 Maintenance Instructions	6-1
6.1 Engine Oil Recommendations	6-1
6.1.1 Oil Type	6-1
6.2 Fuel Recommendations	6-2
6.2.1 General Fuel Recommendations	6-2
6.2.2 Fuel Type	6-2
6.3 Hydraulic System	6-2
6.4 Lug Nuts	6-3
6.5 Brakes	6-3
6.6 Mixer Drive Chain Tension	6-3
6.7 Drive Wheel Chain Tension	6-4
6.8 Periodic Maintenance	6-5
6.9 Maintenance Schedule	6-5
6.10 Service Instructions	6-6
6.11 General Maintenance Parts	6-6
6.12 Recommended Fluids and Lubricants	6-6

Table of Contents

6.13 Storing Procedures	6-6
7.0 About the Illustrated Parts List.....	7-1
7.1 Ordering Crafcoc Parts	7-1
7.2 Paint Mixer Parts List	7-2
7.3 Hydraulic Diagram.....	7-8

List of Figures

Figure 5-1 Control Station	5-6
Figure 6-1 Recommended Engine Oil Viscosity	6-1
Figure 6-2 Lug Bolt Tightening Sequence	6-3
Figure 6-3 Mixer Chain Tension Adjustment	6-4
Figure 6-4 Mixer/Drive Wheel Chain Tension	6-4
Figure 6-5 Drive Wheel Chain Adjustment	6-5
Figure 7-1 Front Isometric View	7-2
Figure 7-2 Drive Wheel Components	7-4
Figure 7-3 Agitator Components	7-5
Figure 7-4 Engine/Hydraulic Pump.....	7-6
Figure 7-5 Tank Valve.....	7-7
Figure 7-6 Hydraulic Diagram (Hose Kit 49020N)	7-8

List of Tables

Table 2-1 Safety Symbols and Notices	2-3
Table 2-2 Safety Symbols and Notices (Continued)	2-4
Table 4-1 Machine Specifications.....	4-1
Table 5-1 Preparing the Machine for Start Up	5-1
Table 5-2 Starting the Engine.....	5-2
Table 5-3 Starting the Engine Continued.....	5-3
Table 5-4 Adding Material to the Tank	5-3
Table 5-5 Mixing the Material	5-4
Table 5-6 Pouring Material	5-4
Table 5-7 Operating the Drive Wheel.....	5-4
Table 5-8 Operating the Drive Wheel (Continued).....	5-5
Table 5-9 Cleaning Out the Material Tank.....	5-5
Table 5-10 Stopping the Engine.....	5-5
Table 5-11 Tongue Jack Operation	5-6
Table 6-1 Mixer Chain Tension Adjustment.....	6-3
Table 6-2 Drive Wheel Chain Tension Adjustment	6-4
Table 6-3 Maintenance Schedule.....	6-5
Table 6-4 Service Instructions.....	6-6
Table 6-5 General Maintenance Parts.....	6-6
Table 7-1 Front Isometric View Parts List.....	7-3
Table 7-2 Drive Wheel Components Parts List.....	7-4
Table 7-3 Agitator Components Parts List.....	7-5
Table 7-4 Engine/Hydraulic Pump Parts List	7-6
Table 7-5 Tank Valve.....	7-7
Table 7-6 Hydraulic Diagram (Hose Kit 49020N).....	7-9

Chapter 1 Introduction

1.0 About This Manual

This manual is supplied with each new CrafcO E-Z Paint Mixer. The manual assists your machine operators in the proper use of the E-Z Paint Mixer and provides information about the machine's mechanical functions for trouble-free operation.

Your CrafcO E-Z Paint Mixer is specially made to give excellent service and save maintenance expense. However, as with all specially engineered equipment, you get best results at minimum cost if you:

Operate your machine as instructed in this manual.

Maintain your machine regularly as stated in this manual.

1.1 How to use this manual:

This manual is formatted to start each new chapter on the right page. There may be a blank page on the left page if the previous chapter ends on the right page.

If you are viewing this in a digital format (PDF) the following features are available:

1. The Table of Contents, List of Tables, and List of Figures are all hyperlinks, when left mouse clicked on section, table, or figure you will be sent to that page.
2. The blue highlighted text throughout the manual is a hyperlink, when left mouse clicked you will be sent to that page, table, or figure.
3. The panel to the left in the PDF is a bookmarks panel, if you left mouse click on any section/heading in the bookmarks panel you will be sent to that page.

Chapter 2 Safety

2.0 Safety Precautions

For more in-depth safety information, please see Safety Manual (P/N 26221) which comes with the machine. Or contact your nearest authorized Crafcoc Distributor at crafcoc.com/Distributors.

2.1 General Safety

- Crafcoc, Inc. assumes no liability for an accident or injury incurred through improper use of the machine.
- Read this manual thoroughly before operating the machine.
- Obey all CAUTION and WARNING signs posted on the machine.
- Make sure an operator fully knows how to operate the machine before using the machine.

2.2 Personal Safety

- Eye and ear protection devices are required when operating the machine.
- Wear long pants, work gloves and heavy leather boots or shoes.
- Keep hands, feet, and clothing away from all moving parts.

2.3 Equipment or Operational Safety

- Do not operate the machine in buildings or work areas that do not have sufficient airflow.
- Always keep a correctly maintained fire extinguisher near the machine and know how to use it.
- Check equipment before every use.
- Do not operate the equipment when fatigued or under the influence of alcohol or drugs.
- Do not modify the equipment.
- Know how to operate the equipment, fully read the manual.
- Shut down engine prior to refilling fuel tank.
- Keep hands, feet, and clothing away from all moving parts.
- Replace any hoses or belts which show signs of wear, fraying, or splitting. Assure all fittings and joints are tight and no leaks are present.
- Use only approved hoses and replacement parts.
- Tighten all bolts and screws every 100 hours of machine operation.
- Never attempt to make repairs to the equipment when the engine is running.
- Never operate the E-Z Paint Mixer without belt guards in place.
- Never transport the E-Z Paint Mixer with the engine running.
- Never exceed maximum recommended engine RPM.
- Never leave E-Z Paint Mixer unattended while engine is running.
- Do not allow Riders on machine when in motion or during transport.
- Place the agitator control lever in neutral whenever and before opening the material tank lid.

Chapter 2 Safety

2.4 California Proposition 65

The state of California currently maintains a list of chemicals that can cause cancer, birth defects or other reproductive harm. Your Crafco, Inc. equipment comes with the following warnings

2.4.1 All Crafco Inc. Equipment

 **WARNING:** Cancer and Reproductive Harm - www.P65Warnings.ca.gov
2647 1N

2.4.2 All Crafco Inc. Equipment using a gasoline engine

 **WARNING:** Breathing engine exhaust exposes you to chemicals known to the State of California to cause cancer and birth defects or other reproductive harm.

- Always start and operate the engine in a well-ventilated area.
- If in an enclosed area, vent the exhaust to the outside.
- Do not modify or tamper with the exhaust system.
- Do not idle the engine except as necessary.

For more information go to www.P65warnings.ca.gov/diesel.







26157

Chapter 2 Safety

2.5 Safety Symbols and Notices





Important safety symbols and notices are marked on the machine and in this manual. Failure to comply could result in equipment damage, operational malfunction, serious injury, or death. Please read and comply with all symbols and notices. The table below includes the most commonly used symbols and notices.

Table 2-1 Safety Symbols and Notices

Symbol	Item	Remarks
WARNING	Warning	Refers to possible bodily injury or death.
CAUTION	Caution	Refers to possible equipment damage or operational malfunction.
	Severe Burn Hazard	Hot surfaces can cause severe burns.
	Protective Shoes	Wear hard-soled work shoes.
	Protective Gloves	Wear heat resistant gloves.
	Protective Face or Eye Wear	Wear face shield or safety glasses.
	Hearing Protection	Wear ear plugs or earmuffs.
	Body Crush Hazard	Do not stand between trailer and hitch when connecting unit to a tow vehicle.

Chapter 2 Safety

Table 2-2 Safety Symbols and Notices (Continued)

Symbol	Item	Remark
	Crush Hazard	Keep feet and legs clear.
	Pinch Hazard	Keep hands and feet clear.
	Exhaust Hazard	Avoid breathing engine exhaust.
	High Pressure Fluid Hazard	Do not use hands to search for leaks, use cardboard instead.
	Read Manual	Read and understand operator and safety manuals before operating machine.

Chapter 3 Warranty Information

3.0 Limited Warranty

Crafco, Inc. (Manufacturer), or one of its affiliated distributors, will replace for the original purchaser free of charge any parts found upon examination by the Manufacturer, to be defective in material or workmanship. This warranty is for a period **two years** from the invoice date, but excludes engine or components, tires, and battery as these items are subject to warranties issued by their manufacturers.

Crafco, Inc. shall not be liable for parts that have been damaged by accident, alteration, abuse, improper lubrication/maintenance, normal wear, or other cause beyond our control.

The warranty provided herein extends only to the repair and/or replacement of those components on the equipment covered above and does not cover labor costs. The warranty does not extend to incidental or consequential damages incurred as a result of any defect covered by this warranty.

All transportation and labor costs incurred by the purchaser in submitting or repairing covered components must be borne by the purchaser. Crafco, Inc. specifically disavows any other representation, warranty, or liability related to the condition or use of the product.

CAUTION

Use of replacement parts other than genuine Crafco parts may impair the safety or reliability of your equipment and nullifies any warranty.

Chapter 3 Warranty Information

3.1 Warranty Claim Instructions

Crafco, Inc. warrants parts and machinery purchased through Crafco or one of its affiliated distributors for two years from the invoice date. Wear items are not covered under the Crafco, Inc. limited warranty. A wear item is defined as but not limited to; material pumps, sealing tips, tires, etc.

If parts fail to function within two years of invoice date, a return authorization number (RA) must be obtained. If the part was purchased through Crafco, Inc., please contact Crafco returns department at [Returns@Crafco.com](mailto>Returns@Crafco.com) for an RA number or if purchased through a Crafco distributor please contact your distributor.

Note: if the part has a serial number associated with it, for example; a machine or electric hose or wand, this must be furnished when requesting the RA number. The customer will be emailed or faxed an RA form with all instructions to return the item to Crafco, Inc. See example. If the part is found to be within the two-year warranty period and has not been abused or modified, a credit will be issued to the customer's account or credit card. The customer may request the part be replaced instead of a credit, if desired.

Note: All engine warranties are covered through the engine manufacturer. If you need information for a distributor in your area, please contact us and we will direct you to the closest engine distributor.

All parts returned are tested and evaluated. If the part has been modified in any way without prior consent from a Crafco, Inc. representative, warranty is void.

Please follow the instructions stated below when calling in a Warranty Claim. Failure to follow these procedures may be cause to void the warranty.

Call your local Crafco Distributor. If you do not know who your local distributor is, call a Crafco Customer Service Representative, (Toll Free 1-800-528-8242) for name, location, and telephone number.

On contacting the distributor, be prepared to identify the serial number, model number, engine number, engine manufacturer, and the date of purchase if available.

Should the cause of the malfunction be a defective part, the Distributor will advise you of the procedure to follow for a replacement.

The warranty is valid only for parts, which have been supplied or recommended by Crafco, Inc.

If you have any additional questions regarding warranty repairs and parts, please do not hesitate to call toll free 1-800-528-8242.

For Warranty:

Crafco, Inc.

25527 South Arizona Avenue, Chandler, AZ
85248

Phone: (480) 655-8333 or (800) 528-8242

Fax: (480) 655-1712

For all other inquires:

Crafco, Inc.

6165 W Detroit St,
Chandler, AZ 85226

Phone: (602) 276-0406 or (800) 528-8242

Fax: (480) 961-0513

CustomerService@crafco.com

Chapter 4 Machine Specifications

4.0 Machine Specifications

Table 4-1 Machine Specifications

Specification	P/N 49000N E-Z Paint Mixer
Holding Tank Capacity	165 Gallons (625 Liters) or 1,800 lbs. (816.5 kg)
Tank Construction	Heavy Duty Steel
Tank Opening Size	38-1/2" X 29-3/4"
Engine (Gasoline)	Model – GX200 Air-cooled 4-Stroke OHV 5.8 HP (4.3 kW) @ 3,600 RPM
Fuel Tank Capacity (Gasoline)	3.3 U.S. Qt. (3.1 Liters)
Hydraulic Tank Capacity	9 Gallons (34.07 Liter)
Hydraulic Pump	Hydraulic Gear Pump - 0.61 in ³ /rev Displacement
Shipping Weight	1,640 lbs. (934 kg)

Chapter 5 Operating Instructions

5.0 Operating Instructions

The Crafcoco E-Z Paint Mixer was designed to mix Acrylic Resurfacer and Color Surface Coatings in large batches in a self-contained, self-propelled, mobile trailered unit. It is designed to give excellent service and save maintenance expense. However, as with all specifically engineered equipment, you can get the best results at minimum cost if you operate your machine as instructed, and maintain it regularly as instructed in this manual.

CRAFECO Inc. and its Distributors assume no liability for accident or injury incurred through improper use of this machine.

DO NOT operate machine without reading operator’s manual and being thoroughly familiar with controls.

Note: DO NOT attempt to operate the machine without using these and all other instructions.

5.1 Preparing the Machine for Start Up

Table 5-1 Preparing the Machine for Start Up

Step	Action
1	Engine should be turned to the “OFF” position before doing any work on the equipment. This will help prevent injuries.
2	Check engine crankcase oil. Add oil if low. Refer to Engine Operators Manual.
3	Fill engine gas tank with clean, fresh, unleaded gasoline. See “Fuel Recommendations” in Engine Operators Manual.
4	Check engine cooling air intake and external surfaces of engine. Clean if dirty or obstructed.
5	Check that the air cleaner components and all shrouds, equipment covers, and guards are in place and securely fastened.
6	Check hydraulic fluid level in the hydraulic reservoir at 70°F. Add fluid as necessary.
7	Make sure hydraulic metering valves are in the neutral position.
	WARNING
	<p>The safe operation of this machine is the operator’s responsibility. Use extreme care when operating this machine; safety is the result of being careful and paying attention to details.</p> <p>Always put on protective clothing, gloves, hard-sole shoes, and safety glasses or a face shield.</p> <p>Be sure that all joints and fittings are tight and leak proof. Immediately replace any hose, which shows any signs of wear, fraying, or splitting. Tighten all bolts, nuts, and screws every 100 hours.</p>

Chapter 5 Operating Instructions

5.2 Machine Start Up

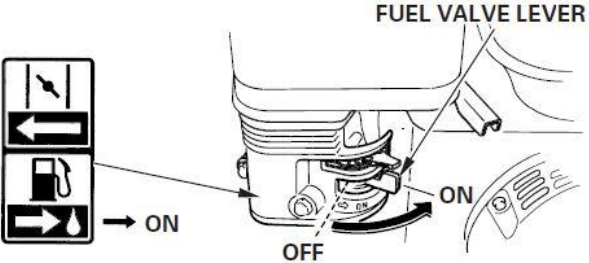
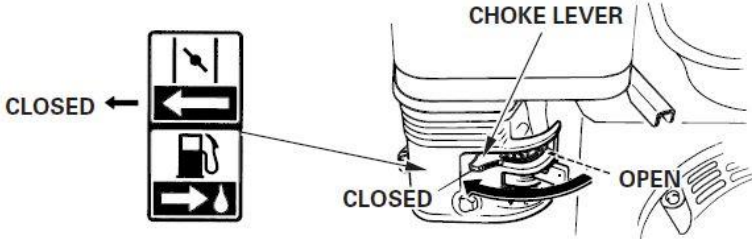
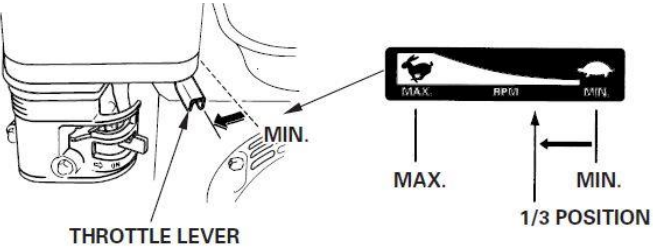
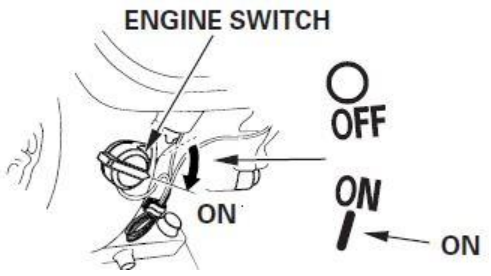

It is recommended that you read the entire Engine Operators Manual before starting the engine.

Table 5-2 Starting the Engine

Step	Action
1	<p>To start engine, move the fuel valve lever to the ON position.</p> 
2	<p>To start a cold engine, move the choke lever to the CLOSED position. To restart a warm engine, leave the choke lever in the OPEN position.</p> 
3	<p>Move the throttle lever away from the MIN. position, about 1/3 of the way toward the MAX position.</p> 
4	<p>Turn the engine switch to the ON position.</p> 

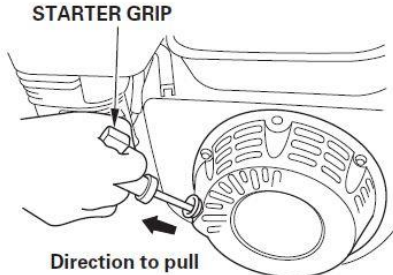

Chapter 5 Operating Instructions

Table 5-3 Starting the Engine Continued

Step	Action
5	<p>Pull the starter grip lightly until you feel resistance, then pull briskly in the direction of the arrow as shown below. Return the starter grip gently.</p> 
	<p style="text-align: center;">CAUTION</p> <p>Do not allow the starter grip to snap back against the engine. Return it gently to prevent damage to the starter.</p>
6	Gradually move the choke lever to the OPEN position as the engine warms up.
7	Position the throttle lever for the desired engine speed.

5.3 Loading Material

Table 5-4 Adding Material to the Tank

Step	Action
	<p style="text-align: center;">WARNING</p> <p>Do not engage the mixer when opening the tank lid. Control valve handle should be in the neutral position when adding material to the tank.</p>
1	Disengage rubber draw latches that hold the lid down and rotate lid up so that it is resting on the lid support bar.
2	Material can then be poured into the unit through the lid opening by bucket or gravity fed from the bed of a truck from a barrel or tote.
	<p style="text-align: center;">CAUTION</p> <p>Do not fill the unit with more than 165 gallons (625 L) or 1,800 lbs. (816.5 kg) of material, whichever is the greater of the two. The 165 gallon fill level is approximately 7-3/4 inches above the center of the agitator shaft. Filling the machine beyond this level or weight, will surpass the weight rating of the axle. The extra weight can also affect the machine's ability to drive itself (especially up an incline).</p>
3	Mix according to the coating manufacture's recommendations.

Chapter 5 Operating Instructions

5.4 Mixer Operation

Table 5-5 Mixing the Material

Step	Action
1	Engage the hydraulic metering valve handle marked “Mixer” up to turn the mixer in a clockwise rotation or down to turn the mixer in a counterclockwise rotation. See Figure 5-1 . The mixer speed is adjustable based on the position of the handle. The more the handle is moved away from the neutral position the faster the agitator will turn.
2	To stop the mixer, return the hydraulic valve to the neutral position.
	WARNING
	Do not operate the mixer with the lid open. Place the mixer control handle in the neutral position whenever the lid is opened.

5.5 Pouring Material

Table 5-6 Pouring Material

Step	Action
1	Remove the Cam & Groove Dust Cover from the application spout.
2	Place a five gallon bucket or other transporting apparatus under the spout.
3	Open the applicator valve by pulling up on the locking handle and rotating the handle counterclockwise until the desired flow speed is reached.
4	Once the desired level is reached, close the valve.

5.6 Operating the Drive Wheel

Table 5-7 Operating the Drive Wheel

Step	Action
	WARNING
	When driving the unit, be aware of surrounding objects or obstacles to avoid collisions. Be especially cautious when other people are nearby. Also be aware of any trip hazards and/or foot placement to avoid accidents and injury.
1	Engage the hydraulic metering valve handle marked “Drive Wheel” up to move the unit in a forward direction or down to move the unit in the reverse direction. See Figure 5-1 . The drive speed is adjustable based on the position of the handle. The more the handle is moved away from the neutral position the faster the unit will move. Note: engine should be at full throttle when driving the unit when loaded with material to ensure it has enough power to drive the unit.
2	To steer the unit, either push or pull on the steering arm to turn the drive wheel in the desired direction of travel. See Figure 5-1 .
3	To stop the unit, return the hydraulic valve to the neutral position.

Chapter 5 Operating Instructions

Table 5-8 Operating the Drive Wheel (Continued)



CAUTION	
	When valve is placed in neutral, the ports to the drive motor are blocked from flow. This should act as a brake when the valve is in the neutral position. However, the unit may not come to a complete stop right away when going to neutral, plan your stop ahead of time to make sure unit stops at the desired spot. Allow more time for stopping with a fully loaded unit and/or stopping on an incline. If it's necessary to park the unit on an incline, for added safety, the wheel/s should be chocked to prevent unexpected movement of the unit.

5.7 Shutting Down the Machine

Table 5-9 Cleaning Out the Material Tank

Step	Action
1	Empty the material tank of all material.
2	Pour 5 gallons of water into the material tank and engage the agitator for several minutes.
3	Drain the left over slurry into a bucket. Note: this leftover material can be reused in a future projects mix if properly stored.
4	Replace the Cam & Groove Dust Cover onto the application spout.

Table 5-10 Stopping the Engine

Step	Action
	CAUTION
	To stop the engine in an emergency, simply turn the engine switch to the OFF position. Under normal conditions, use the following procedure.
1	Return control valve levers to the neutral position.
2	Move the Throttle lever to the MIN. position.
3	Turn the engine switch to the OFF position.
4	Turn the fuel valve lever to the OFF position.
	CAUTION
	Do not store or transport the machine with the fuel valve in the on position.

Chapter 5 Operating Instructions

5.8 Using the Hydraulic Tongue Jack

Table 5-11 Tongue Jack Operation

WARNING	
	Keep bystanders clear of the machine when operating the tongue jack to avoid accidents or injury.
1	Start the engine. Refer to Section 5.2 . For operation of the tongue jack, the engine can be throttled back to help slow down the speed of the jack.
2	Engage the hydraulic metering valve marked “Tongue Jack”. See Figure 5-1 . To raise the tongue, lift up on the valve handle. The jack speed is adjustable depending on the position of the handle. The farther away from neutral the handle is moved the faster the jack will move. Note: the tongue jack valve has a spring detent and will automatically return the handle to neutral when released.
3	To lower the tongue, push down on the handle. Speed is controlled by how far the handle is moved away from neutral. Fully retract the cylinder rod back into the housing. Note: whenever not in use, the cylinder rod should be fully retracted into the cylinder housing.
4	If desired the jack can be rotated out of the way. Pull the jack retaining pin, rotate the jack 90° and replace the retaining pin.
5	Shutdown the engine. Refer to Table 5-10 Stopping the Engine .

Figure 5-1 Control Station



Chapter 6 Maintenance Instructions

6.0 Maintenance Instructions

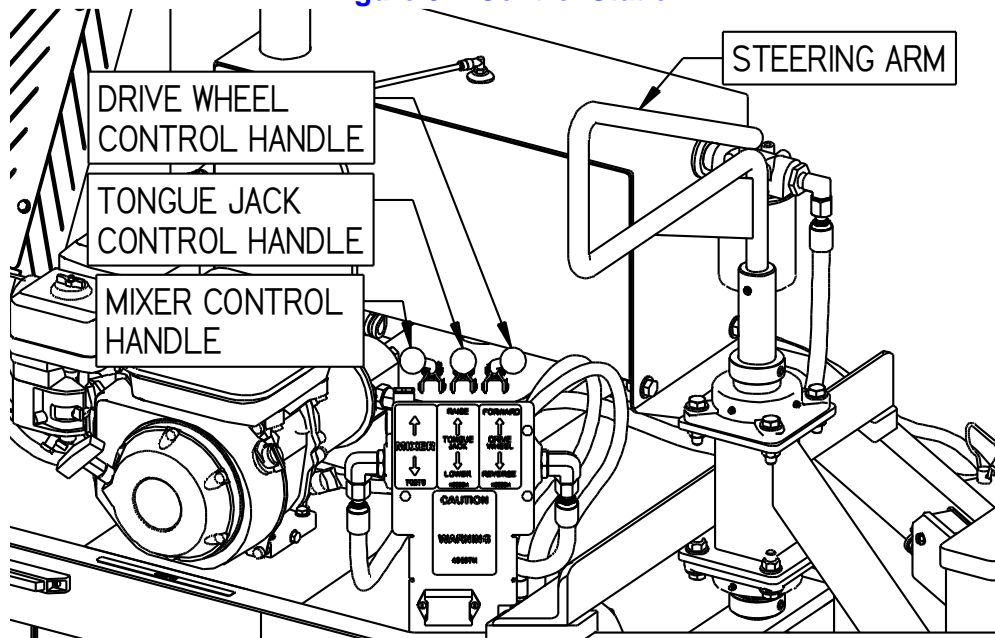
This chapter contains all normal maintenance instructions to properly maintain your machine.

6.1 Engine Oil Recommendations

Using the proper type and weight of oil in the crankcase is extremely important. Failure to use the correct oil, or using dirty oil, causes premature engine wear and failure.

Check engine oil daily.

6.1.1 Oil Type

Use 4-stroke motor oil that meets or exceeds the requirements for API service classification SJ or later (or equivalent). Always check the API service label on the oil container to be sure it includes the letters SJ or later (or equivalent). SAE 10W-30 is recommended for general use. Other viscosities shown in the chart below may be used when the average temperature in your area is within the indicated range. **Figure 6-1**.

Note: Using oil other than service class SJ or later (or equivalent) or extending oil change intervals longer than recommended can cause engine damage. Refer to the Maintenance instructions in the engine owner's manual for detailed oil check, oil change, and oil filter change procedures and intervals.

For an online PDF manual, visit <https://engines.honda.com/models/series/gx>

Figure 6-1 Recommended Engine Oil Viscosity

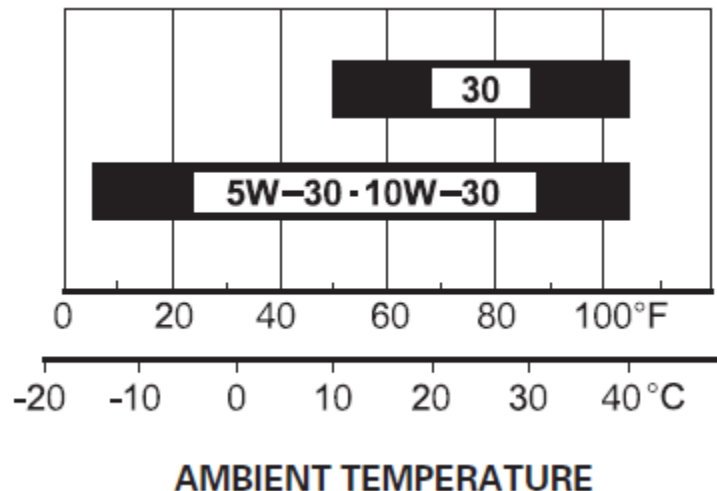

Chapter 6 Maintenance Instructions

6.2 Fuel Recommendations

WARNING

Explosive Fuel!

Gasoline is extremely flammable, and its vapors can explode if ignited. Store gasoline only in approved containers, in well ventilated, unoccupied buildings away from sparks or flames. Do not fill the fuel tank while the engine is hot or running since spilled fuel could ignite if it comes in contact with hot parts or sparks from ignition. Do not start the engine near spilled fuel. Never use gasoline as a cleaning agent.

6.2.1 General Fuel Recommendations

Purchase gasoline in small quantities and store in clean, approved containers. A container with a capacity of 5 gallons or less with a pouring spout is recommended. Such a container is easier to handle and helps eliminate spillage during refueling.

To minimize gum deposits in your fuel system and to ensure easy starting, do not use gasoline left over from the previous season.

Do not add oil to the gasoline.

Do not over-fill the fuel tank. Leave room for the fuel to expand.

6.2.2 Fuel Type

For best results use only clean, fresh, unleaded gasoline with a pump sticker octane rating of 86 or higher. In countries using the Research method, it should be 91 octane minimum.

Unleaded gasoline is recommended as it leaves less combustion chamber deposits. Regular unleaded gasoline may be used containing no more than 10% ethanol (E10) or 5% Methanol by volume. In addition, Methanol must contain cosolvents and corrosion inhibitors. Use of fuels with content of Ethanol or Methanol greater than shown above may cause starting and/or performance problems. It may also damage metal, rubber, and plastic parts of the fuel system.

6.3 Hydraulic System

Check hydraulic fluid daily

Change hydraulic filter every 250 hours of machine operation

Change hydraulic fluid every 500 hours of operation.

Chapter 6 Maintenance Instructions

6.4 Lug Nuts

Torque all nuts/bolts before first road use and after each wheel removal. Check and torque after the first 10 miles, 25 miles, and again at 50 miles. Check periodically thereafter.

Torque in stages as follows:

First stage 20-25 foot-pound (ft-lb)

Second stage 50-60 foot pound (ft-lb)

Third stage 90-120 foot pound (ft-lb)

Tighten bolts and nuts in the sequence shown in **Figure 6-2**

Figure 6-2 Lug Bolt Tightening Sequence

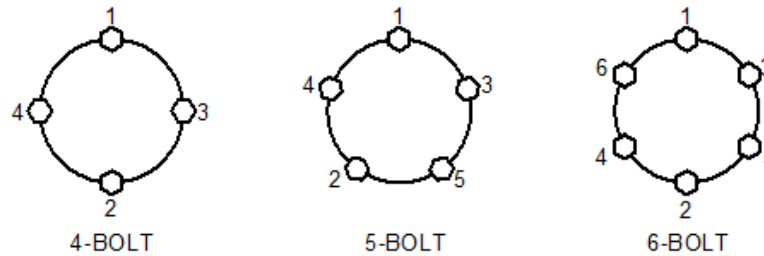

6.5 Brakes

Check the brakes daily.

6.6 Mixer Drive Chain Tension

Check the chain tension while doing hydraulic oil service every 250 hours of machine operation. The agitator drive chain should have 1/4" of deflection on the center of the chain.

Check chain for loose or worn parts. Replace as necessary.

Check sprockets for wear. Replace as necessary.

Table 6-1 Mixer Chain Tension Adjustment

Step	Action
1	Loosen the 4 screws on the sides of the hydraulic motor adjustment bracket. See Figure 6-3
2	Use two 3/8-16 jack screws in the top two holes of the bracket to adjust its position. See Figure 6-3
3	Measure the deflection in the chain halfway through its distance. See Figure 6-4
4	Once there is 1/4" of deflection, retighten the 4 mounting screws on the side of the bracket, and remove the jack screws.

Chapter 6 Maintenance Instructions

Figure 6-3 Mixer Chain Tension Adjustment

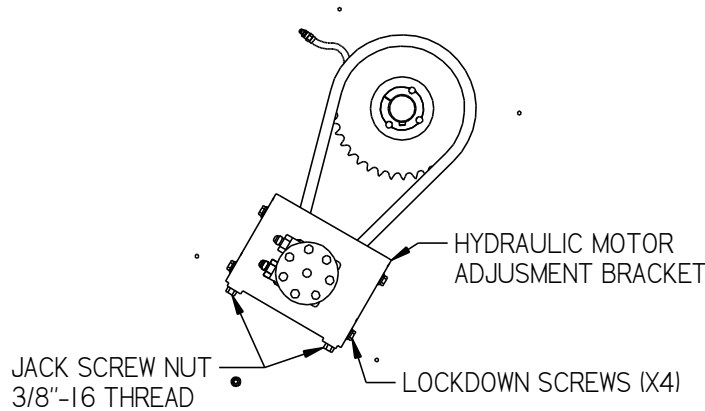
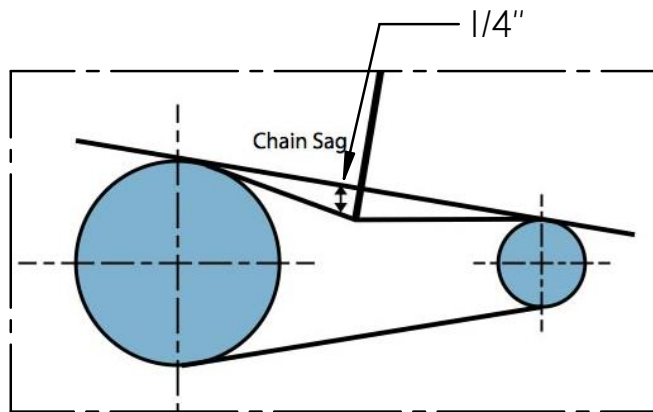

Figure 6-4 Mixer/Drive Wheel Chain Tension



6.7 Drive Wheel Chain Tension

Check the chain tension while doing hydraulic oil service every 250 hours of machine operation. The drive wheel chain should have 1/4" of deflection on the center of the chain.

Check chain for loose or worn parts. Replace as necessary.

Check sprockets for wear. Replace as necessary.

Table 6-2 Drive Wheel Chain Tension Adjustment

Step	Action
1	Loosen the 4 bolts that hold the hydraulic motor in place. See Figure 6-5
2	Slide the motor in the slots to tighten or loosen chain.
3	Measure the deflection in the chain halfway through its distance. See Figure 6-4
4	Tighten the 4 bolts that hold the hydraulic motor in place.

Chapter 6 Maintenance Instructions

Figure 6-5 Drive Wheel Chain Adjustment

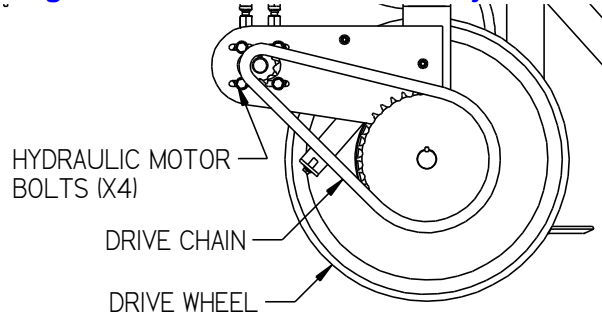

6.8 Periodic Maintenance

Follow a regular schedule of inspection and servicing, based on operating hours. Keep an accurate logbook of maintenance, servicing, and operating time. Use the factory recommended Periodic Maintenance Schedule (based on favorable operating conditions) to serve as a guide to get long and efficient engine life. **Table 6-3 Maintenance Schedule**

6.9 Maintenance Schedule

These required maintenance procedures should be performed at the recommended intervals. They should also be included as part of any seasonal tune-up.

Table 6-3 Maintenance Schedule

Item	Procedure	Each Use	100	250	500
Engine	Check oil level	X			
	Check air cleaner for dirty, loose, or damaged parts*	X			
	Check air intake and cooling areas, clean as necessary*	X			
	Change oil**		X		
Other Engine Maintenance	Refer to the manufacture's operating and maintenance instructions of the engine.				
Hydraulic Oil	Check oil level	X			
	Change oil				X
Hydraulic Oil Filter	Change			X	
Agitator Chain Tension	Check			X	
Drive Wheel Chain Tension	Check			X	
Wheel Bearings	Clean and re-pack using a good grade of bearing grease	Every 24,000 miles or two years			

*Perform these maintenance procedures more frequently under extremely dusty, dirty conditions.

**Change after the first 20 hours.

Chapter 6 Maintenance Instructions

6.10 Service Instructions

Table 6-4 Service Instructions

Step	Action
1	Do a general inspection of the machine at least once a week.
2	Replace all worn or damaged parts
3	Make necessary adjustments and tighten all loose nuts, bolts, or screws.
4	Watch for leaks. Tighten fittings or repair as necessary.
5	Clean the external surfaces of the machine at regular intervals.

6.11 General Maintenance Parts

Table 6-5 General Maintenance Parts

Recommended Quantity	Description	Part Number
1	Engine Air Filter	49109N
1	Hydraulic Oil Filter	22071

6.12 Recommended Fluids and Lubricants

Application	Recommended	Capacity
Engine Oil	Refer to engine manual	Refer to engine manual
Hydraulic Oil	Shell AW Hydraulic 46 or similar	8.5" (cm) depth, approx. 9 Gals. (L)

6.13 Storing Procedures

If the machine is to remain inactive for extended periods of time, the unit should be stored in a covered, dry place if possible. Refer to the Engine Operator's Manual for engine storage procedures.

Chapter 7 Illustrated Parts List

7.0 About the Illustrated Parts List

The Illustrated Parts List (IPL) is designed to help technical service or maintenance personnel correctly identify orderable replacement parts

Illustrations are designed to show general shape and size of a part and the relationship that part has to other parts. Actual size and shape of parts or components may differ or vary from the actual part or component.

7.1 Ordering Crafco Parts

Crafco distributors and Crafco Pavement Preservation Supply Centers are strategically located throughout the United States. Parts can be ordered from your local Crafco distributor or directly from Crafco, Inc. if a distributor is not available in your area.

When ordering parts, give the following information:

- Part Number
- Machine Model
- Serial Number

Write, call, or Fax Crafco, Inc. at the following:

Crafco, Inc. Headquarters

6165 W Detroit St.

Chandler, AZ 85226

Phone: (602) 276-0406

Toll Free: (800) 528-8242

Fax: (480) 961-0513

Visit our website at www.crafco.com

Chapter 7 Illustrated Parts List

7.2 Paint Mixer Parts List

Figure 7-1 Front Isometric View

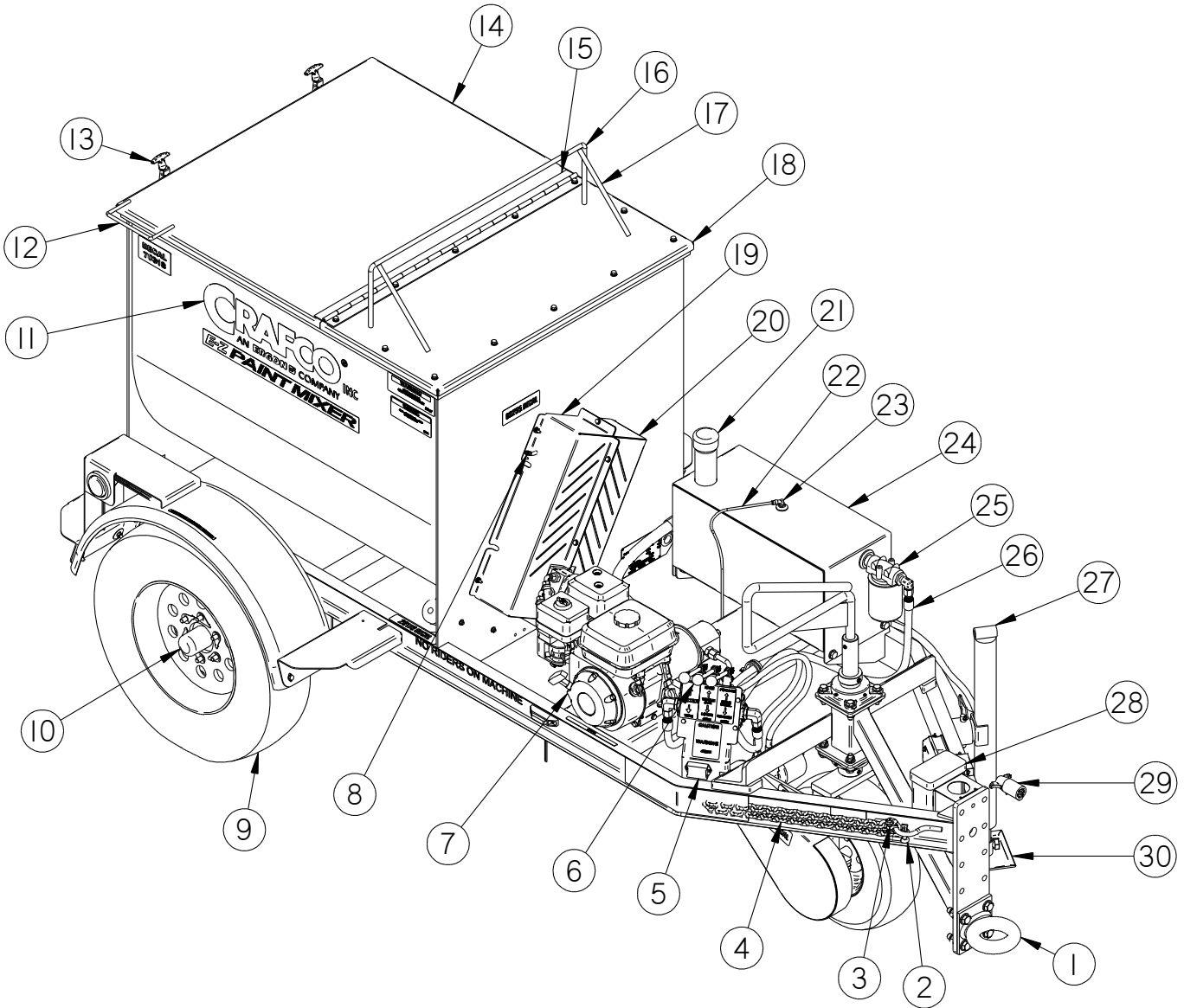

Chapter 7 Illustrated Parts List

Table 7-1 Front Isometric View Parts List

FIG.	ITEM	PART NO.	DESCRIPTION	QTY.
Figure 7-1	1	20014	3" PINTLE HITCH	1
	2	20144	3/8" CHAIN SHACKLE WITH SCREW PIN	2
	3	20132	SHACKLE CONNECTING LINK	2
	4	20130	48" X 3/8" CHAIN	2
	5	24250	HOUR/TACH METER	1
	6	49091N	CONTROL VALVE, 3 SPOOL MONOBLOCK	1
	7	49050N	HONDA GX200 GASOLENE ENGINE	1
	8	70502	BEARING GREASE LINE	1
	9	44342	TIRE WITH RIM ST225/75 R15	2
	10	49011N	AXLE ASSEMBLY, 3500# PAINT MIXER	1
	11	49095N	DECAL KIT, EZ PAINT MIXER	1
	12	56285	DOOR HANDLE	1
	13	45597	RUBBER T-HANDLE DRAW LATCH	2
	14	49058N	COATING MIXER TOP LID	1
	15	49063N	LID HINGE, TANK COVER	1
	16	49036N	LID SUPPORT BAR	1
	17	49037N	LID SUPPORT BAR, STAIGHT	2
	18	49034N	PLATE, TOP COVER	1
	19	70384N	AGITATOR SPROCKET BOTTOM GUARD	1
	20	70383N	AGITATOR SPROCKET TOP GUARD	1
	21	28273	PIPE CAP 2" STANDARD BLACK	1
	22	60232	1/4" O.D. PLASTIC TUBE	2 FT
	23	60233	1/4" 90° PLASTIC TUBE FITTING	1
	24	49070S	HYDRAULIC OIL TANK	1
	25	22070	HYDRAULIC FILTER HOUSING AND FILTER	1
	26	49020N	HYDRAULIC HOSE KIT	1
	27	49075N	HYDRAULIC JACK ASSEMBLY	1
	28	23120	BRAKEAWAY BATTERY WITH CHARGER	1
	29	24227	7 PIN FLAT BLADE CONNECTOR	1
	30	49047N	JACK SAND PAD ASSEMBLY	1

Chapter 7 Illustrated Parts List

Figure 7-2 Drive Wheel Components

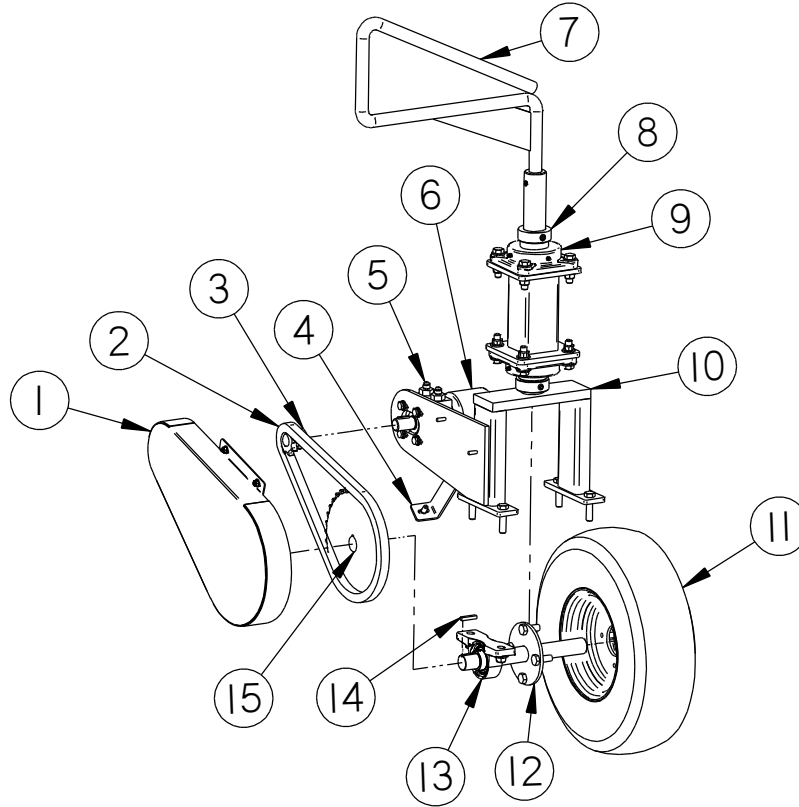

Table 7-2 Drive Wheel Components Parts List

FIG.	ITEM	PART NO.	DESCRIPTION	QTY.
Figure 7-2	1	49055N	CHAIN GUARD ASSEMBLY, DRIVE WHEEL	1
	2	70240	AGITATOR DRIVE CHAIN	1
	3	70239	SPROCKET, #60, 3/4 PITCH, 9 TOOTH, 1" BORE	1
	4	49056N	BRACKET, GUARD SUPPORT	1
	5	22029	#10 O'RING X #6 JIC STRAIGHT ADAPTER	2
	6	45428	HYDRAULIC MOTOR	1
	7	49012N	STEERING ARM ASSEMBLY	1
	8	49046N	SHAFT COLLAR, 1-3/4" DIAMETER	2
	9	70237	1-3/4" BORE, 4 BOLT FLANGE BEARING	2
	10	49015N	YOKE, WELD ASSEMBLY	1
	11	31275N	TIRE AND WHEEL ASSEMBLY, 5.70-8	1
	12	49010N	AXLE ASSEMBLY, DRIVE WHEEL	1
	13	49064N	PILLOW BLOCK BEARING, 1-1/4" SHAFT	2
	14	51453	CONVEYOR DRIVE KEY	1
	15	49048N	SPROCKET, #60, 36 TOOTH, 1-1/4" BORE	1

Chapter 7 Illustrated Parts List

Figure 7-3 Agitator Components

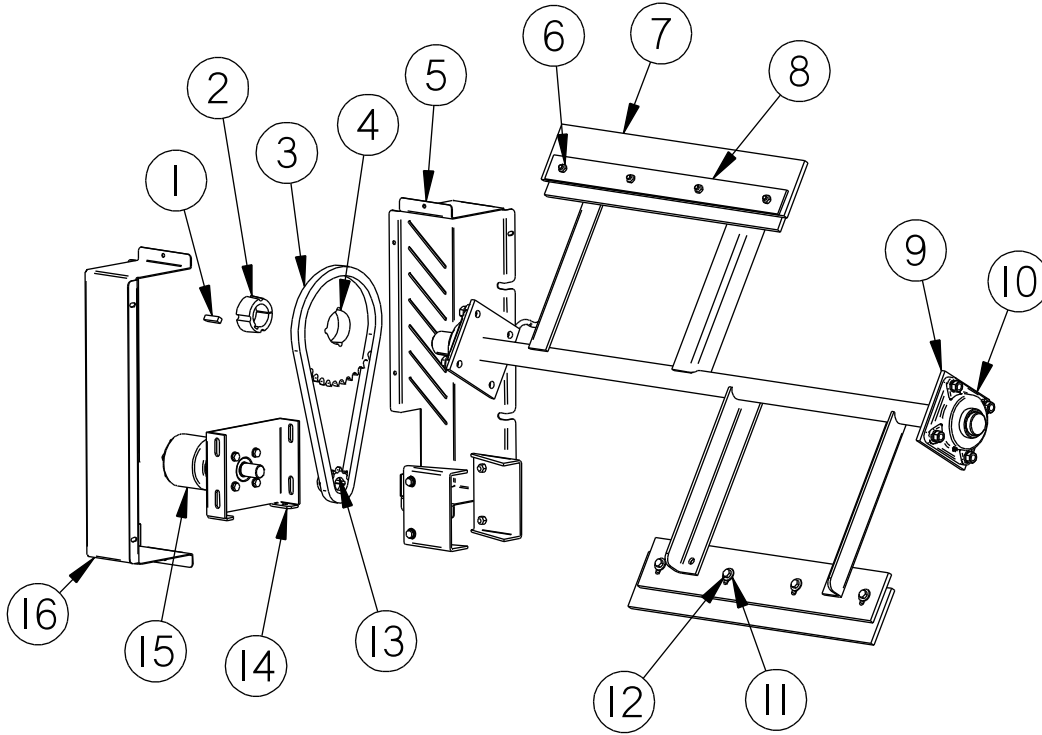

Table 7-3 Agitator Components Parts List

FIG.	ITEM	PART NO.	DESCRIPTION	QTY.
Figure 7-3	1	70233	AGITATOR SHAFT KEY	1
	2	70261	TAPER LOCK BUSHING, 2012-1 3/4	1
	3	70240	AGITATOR DRIVE CHAIN	1
	4	70238	SPROCKET, #60, 36 TOOTH, 1-3/4" SHAFT	1
	5	70383N	AGITATOR SPROCKET TOP GUARD	1
	6	28538	3/8"-16 STOVER NUT	8
	7	49051N	WIPER, AGITATOR PADDLE	2
	8	49066N	PLATE, PADDLE WIPER CLAMP	2
	9	70234	AGITATOR BEARING GASKET	2
	10	70237	1-3/4" BORE, 4-BOLT FLANGE BEARING	2
	11	28634	3/8" FLAT WASHER	8
	12	28733	3/8"-16 THREAD X 1-1/2" GRADE 5 BOLT	8
	13	70239	SPROCKET, #60, 3/4 PITCH, 9 TOOTH, 1" BORE	1
	14	70156	HYD. MOTOR MOUNT/ADJUSTING BRACKET	1
	15	45428	HYDRAULIC MOTOR	1
	16	70384N	AGITATOR SPROCKET BOTTOM GUARD	1

Chapter 7 Illustrated Parts List

Figure 7-4 Engine/Hydraulic Pump

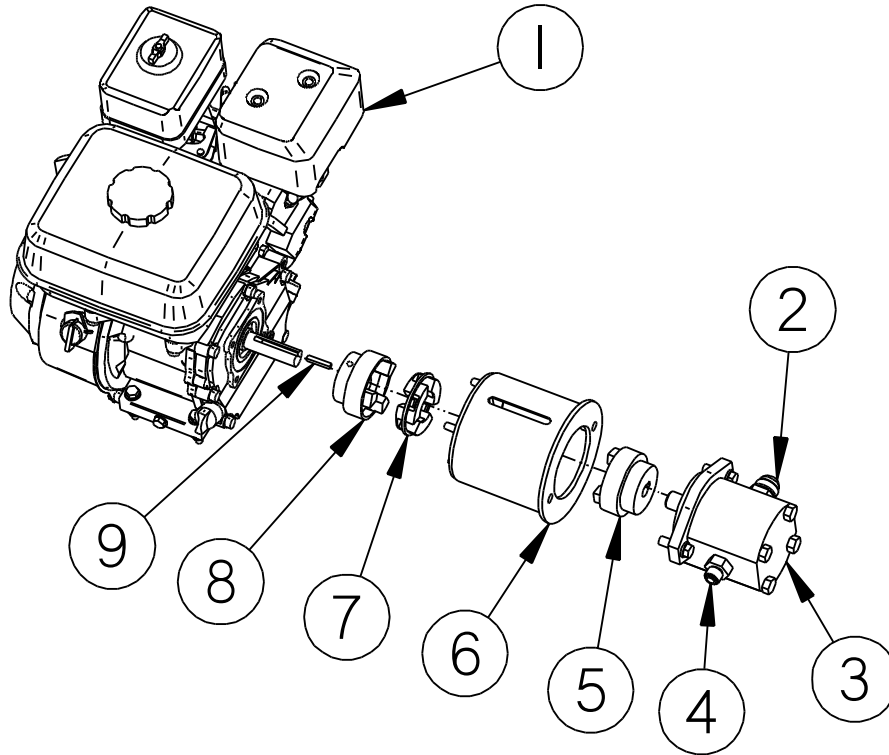

Table 7-4 Engine/Hydraulic Pump Parts List

FIG.	ITEM	PART NO.	DESCRIPTION	QTY.
Figure 7-4	1	49050N	HONDA GX200 GASOLENE ENGINE	1
	2	29819	CONNECTOR-STRAIGHT O-RING	1
	3	70220	HYDRAULIC GEAR PUMP	1
	4	29913	#10 O-RING X #8 JIC STRAIGHT ADAPTER	1
	5	56303	COUPLING HALF, 5/8" BORE, KEYED	1
	6	49080N	COUPLING, HYDRAULIC PUMP	1
	7	44830	SPIDER COUPLING	1
	8	44828	COUPLING HALF 1-100 X 3/4"	1
	9	47332N	3/16" X 1-1/8" LONG KEY	1

Chapter 7 Illustrated Parts List

Figure 7-5 Tank Valve

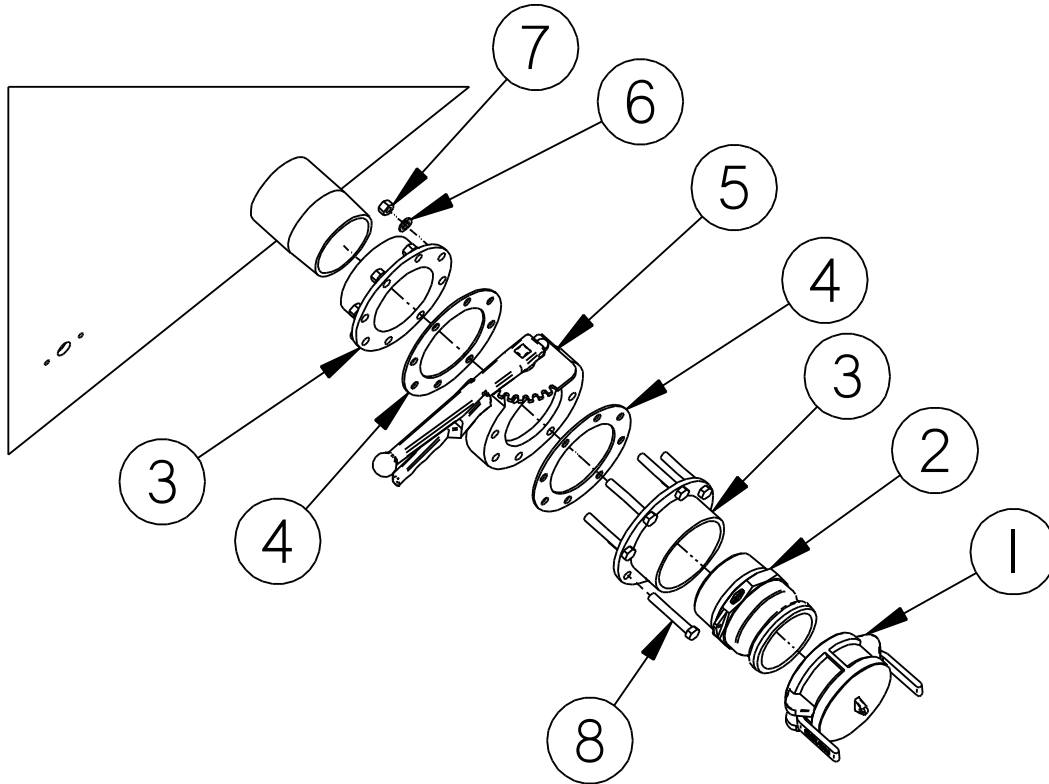

Table 7-5 Tank Valve

FIG.	ITEM	PART NO.	DESCRIPTION	QTY.
Figure 7-5	1	49081N	DUST CAP, 3" CAM & GROOVE	1
	2	49111N	CAM & GROOVE ADAPTER, 3" MALE	1
	3	49061N	ADAPTER, 3" PIPE TO FLANGE	2
	4	49057N	FLANGE GASKET, BUTTERFLY VALVE	2
	5	49052N	VALVE, BUTTERFLY METERING/LOCKING	1
	6	28647	3/8" LOCK WASHER	8
	7	28502	3/8"-16 HEX NUT	8
	8	28736	3/8"-16 X 2-1/2 BOLT	8

Chapter 7 Illustrated Parts List

7.3 Hydraulic Diagram

Figure 7-6 Hydraulic Diagram (Hose Kit 49020N)

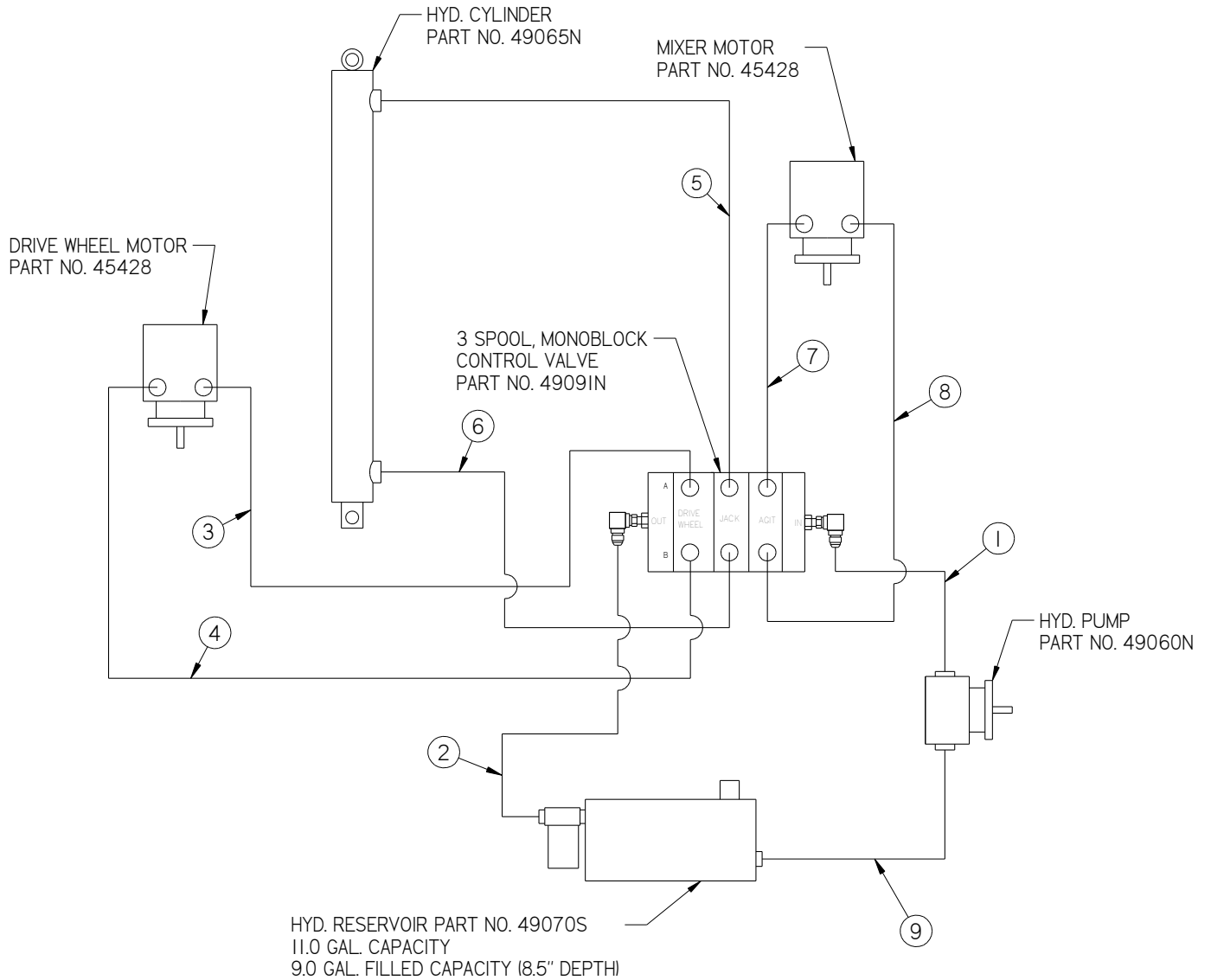

Chapter 7 Illustrated Parts List

Table 7-6 Hydraulic Diagram (Hose Kit 49020N)

FIG.	ITEM	PART NO.	DESCRIPTION	QTY.
Figure 7-6	1	HYDRAULIC PUMP TO CONTROL VALVE "IN" PORT		
		29913	FITTING, #8 JIC TUBE X #10 ORB	REF
		8M3K 8G-8FJX90L 8G-8FJX 19.5	HYDRAULIC HOSE	1
		29917	FITTING, #8 JIC TUBE X #2 ORB 90°	REF
	2	CONTROL VALVE "OUT" PORT TO RESERVOIR		
		29917	FITTING, #8 JIC TUBE X #10 ORB	REF
		8M3K 8G-8FJX 8G-8FJX 53	HYDRAULIC HOSE	1
		29845	FITTING, #8 JIC TUBE X 1/2" NPT	REF
	3	CONTROL VALVE "A" PORT TO DRIVE WHEEL MOTOR		
		22029	FITTING, #6 JIC TUBE X #10 ORB	REF
		6M3K 6G-6FJX 6G-6FJX 30.5	HYDRAULIC HOSE	1
		22029	FITTING, #6 JIC TUBE X #10 ORB	REF
	4	CONTROL VALVE "B" PORT TO DRIVE WHEEL MOTOR		
		22029	FITTING, #6 JIC TUBE X #10 ORB	REF
		6M3K 6G-6FJX 6G-6FJX 30.5	HYDRAULIC HOSE	1
		22029	FITTING, #6 JIC TUBE X #10 ORB	REF
	5	CONTROL VALVE "A" PORT TO HYDRAULIC JACK TOP PORT		
		22029	FITTING, #6 JIC TUBE X #10 ORB	REF
		6M3K 6G-6FJX 6G-6FJX 67.5	HYDRAULIC HOSE	1
		29869	FITTING, #6 JIC TUBE X #8 ORB 90°	REF
	6	CONTROL VALVE "B" PORT TO HYDRAULIC JACK BOTTOM PORT		
		22029	FITTING, #6 JIC TUBE X #10 ORB	REF
		6M3K 6G-6FJX 6G-6FJX 65.5	HYDRAULIC HOSE	1
		29869	FITTING, #6 JIC TUBE X #8 ORB 90°	REF
	7	CONTROL VALVE "A" PORT TO AGITATOR MOTOR		
		22029	FITTING, #6 JIC TUBE X #10 ORB	REF
		6M3K 6G-6FJX 6G-6FJX90S 38.5	HYDRAULIC HOSE	1
		22029	FITTING, #6 JIC TUBE X #10 ORB	REF
	8	CONTROL VALVE "B" PORT TO AGITATOR MOTOR		
		22029	FITTING, #6 JIC TUBE X #10 ORB	REF
6M3K 6G-6FJX 6G-6FJX90S 38.5		HYDRAULIC HOSE	1	
22029		FITTING, #6 JIC TUBE X #10 ORB	REF	
9	HYDRAULIC PUMP TO RESEVOIR			
	29819	FITTING, #12 JIC TUBE X #12 ORB	REF	
	12G4H 12G-16FJX90S 12-12FJX 30	HYDRAULIC HOSE	1	
	29818	FITTING, #16 JIC TUBE X #20 ORB	REF	



©2024 Crafco, Inc.