



CrafcO Sealcoater 550 & 700

Parts Manual - CR300013
Revision 0



Crafco Sealcoater 550 & 700 Part Manual

Serial Numbers

Fill in appropriate fields that apply to this machine

Machine S/N: _____

1st Hose S/N: _____

2nd Hose S/N: _____

1st Pump S/N: _____

2nd Pump S/N: _____

Engine S/N: _____

Compressor S/N: _____

Gear Box S/N (Patcher): _____

Drawings and Part Numbers

PN 93140K (550 Gal. Trailer)
PN 93142K (700 Gal. Trailer)
PN 93141K (550 Gal. Skid – Not Pictured)
PN 93143K (700 Gal. Skid – Not Pictured)

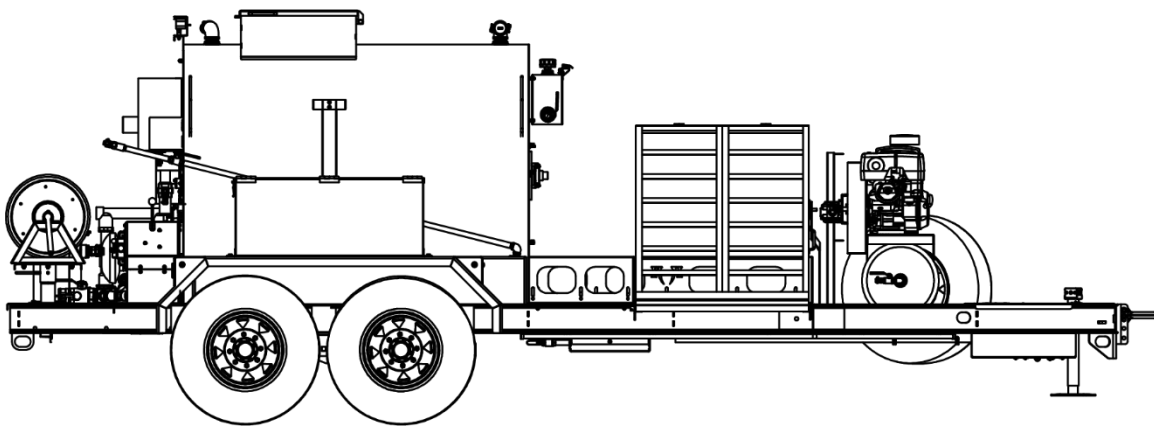

CRAFCO SEALCOATER SIDE VIEW

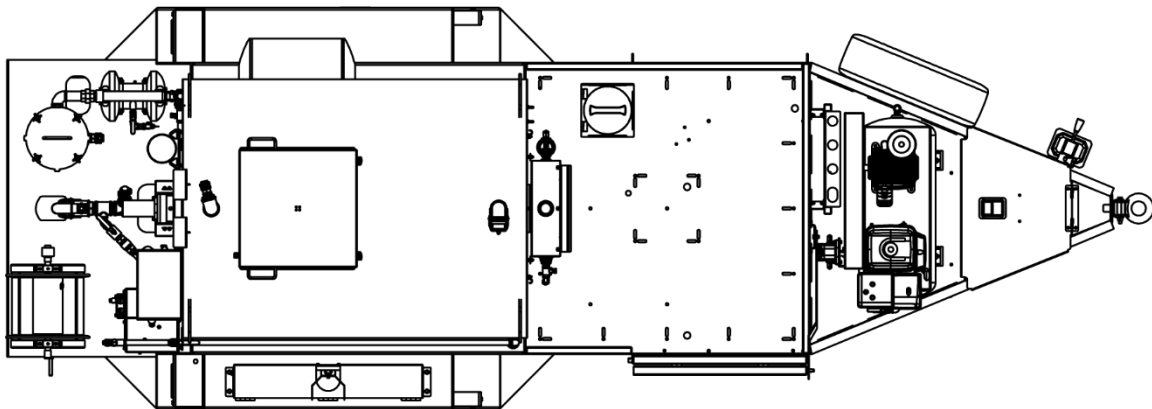

CRAFCO SEALCOATER TOP VIEW

Table of Contents

1.0 About This Manual	1-1
1.1 How to use this manual:	1-1
2.0 Safety Precautions	2-1
2.1 General Safety.....	2-1
2.2 Personal Safety	2-1
2.3 Equipment or Operational Safety.....	2-1
2.4 California Proposition 65.....	2-2
2.5 Safety Symbols and Notices.....	2-3
3.0 Limited Warranty	3-1
3.1 Warranty Claim Instructions.....	3-2
4.0 Machine Specifications	4-1
4.1 Tank Depth Charts	4-2
5.0 Operating Instructions	5-1
5.1 Preparing the Machine for Start Up.....	5-1
5.2 Locations of Valves and Controls	5-2
5.3 Machine Start Up.....	5-6
5.4 Operating the Compressor	5-6
5.5 Operating the Hydraulic Agitator.....	5-6
5.6 Operating the Pump	5-7
5.7 Loading Material into the Tank.....	5-8
5.8 Agitating the Material.....	5-8
5.9 Recirculating the Material	5-9
5.10 Applying Material with the Hand Wand	5-9
5.11 Flushing Material Hose and Hand Wand Using the Water Tank	5-10
5.12 Draining Material Tank.....	5-10
5.13 Shutting Down the Machine	5-11
6.0 Maintenance Instructions	6-1
6.1 Engine	6-1
6.2 Compressor.....	6-1
6.3 Hydraulic System.....	6-1
6.4 Material Pump 1.5"	6-1
6.5 Battery Charger	6-1
6.6 Lug Nuts.....	6-1

Table of Contents

6.7 Brakes.....	6-2
6.8 Tongue Jack.....	6-2
6.9 Agitator Drive Chain Tension.....	6-2
6.10 Cleaning the Sealcoater	6-3
6.11 Maintenance Chart.....	6-3
6.12 Daily Preventative Maintenance (Continued on next page.)	6-4
6.13 Annual Preventative Maintenance	6-6
6.14 Winterizing	6-6
6.15 Service Instructions	6-6
6.16 General Maintenance Parts.....	6-7
6.17 Recommended Fluids and Lubricants	6-7
6.18 Ordering Parts.....	6-8
7.0 Troubleshooting.....	6-9
7.1 Pump Troubleshooting	6-9
7.2 Air Compressor Troubleshooting	6-10

Chapter 1 Introduction

1.0 About This Manual

This manual is supplied with each new Crafco Sealcoater. The manual assists your machine operators in the proper use of the melter applicator and provides information about the machine's mechanical functions.

Your Crafco Sealcoater is specially made to give excellent service and save maintenance expense. However, as with all specially engineered equipment, you get best results at minimum cost if you:

Operate your machine as instructed in this manual.

Maintain your machine regularly as stated in this manual.

1.1 How to use this manual:

This manual is formatted to start each new chapter on the right page. There may be a blank page on the left page if the previous chapter ends on the right page.

If you are viewing this in a digital format (PDF) the following features are available:

- The Table of Contents is hyperlinked, allowing you to quickly navigate to the relevant section.
- The panel to the left in the PDF is a bookmarks panel. If you left mouse click on any section/heading in the bookmarks panel you will be sent to that page.

Chapter 2 Safety

2.0 Safety Precautions

For more in-depth safety information, please see Safety Manual (PN 26221) at crafco.com/manuals/SAFTYMAN.pdf, request one from your Crafco representative, or contact your nearest authorized Crafco Distributor at crafco.com/Distributors.

2.1 General Safety

- Crafco, Inc. assumes no liability for any accidents or injuries incurred through improper use of this machine.
- Read this manual thoroughly before operating the machine.
- Obey all CAUTION and WARNING signs posted on the machine.
- Make sure an operator fully knows how to operate the machine before use.

2.2 Personal Safety

- Always wear protective clothing, gloves, hard-soled shoes, and safety glasses or a face shield be worn at all times by operators of the machine.
- Bodily contact with hot material or surfaces can cause severe burns.
- If the agitation is not stopped before adding material, it can get on an operator's body.
- Keep hands, feet, and clothing away from all moving parts.
- DO NOT point the nozzle at another person.
- DO NOT operate near an open flame.

2.3 Equipment or Operational Safety

- Do not operate the machine in buildings or work areas that do not have sufficient airflow.
- Shut-down the compressor engine before refilling the fuel tank.
- Make sure agitation stops before adding material to the tank.
- Always keep a correctly maintained fire extinguisher near the machine and know how to use it.
- Replace any hoses which show signs of wear, fraying or splitting.
- Make sure all fittings and joints are tight and do not leak each time the machine is used.
- Do not leave the machine unattended while it is running.
- Tighten all bolts and screws every 100 hours of machine operation.
- DO NOT allow emulsion to freeze.
- DO NOT use any type of flame to unclog the emulsion hose or spray ring if they should become clogged.

Chapter 2 Safety

2.4 California Proposition 65

The state of California currently maintains a list of chemicals that can cause cancer, birth defects or other reproductive harm. Your Crafco, Inc. equipment comes with the following warnings:

All Crafco, Inc. Equipment

 **WARNING:** Cancer and Reproductive Harm - www.P65Warnings.ca.gov
26471N

2.4.1

All Crafco, Inc. Equipment using a gasoline engine

2.4.2

 **WARNING:** Breathing engine exhaust exposes you to chemicals known to the State of California to cause cancer and birth defects or other reproductive harm.

- Always start and operate the engine in a well-ventilated area.
- If in an enclosed area, vent the exhaust to the outside.
- Do not modify or tamper with the exhaust system.
- Do not idle the engine except as necessary.





For more information go to www.P65warnings.ca.gov/diesel.
26157

Chapter 2 Safety

2.5 Safety Symbols and Notices





Important safety symbols and notices are marked on the machine and in this manual. Failure to comply could result in equipment damage, operational malfunction, serious injury, or death. Please read and comply with all symbols and notices. The table below includes the most commonly used symbols and notices.

Table 2-1 Safety Symbols and Notices

Symbol	Item	Remarks
WARNING	Warning	Refers to possible bodily injury or death.
CAUTION	Caution	Refers to possible equipment damage or operational malfunction.
	Severe Burn Hazard	Hot material or surfaces can cause severe burns.
	Protective Shoes	Wear hard-soled work shoes.
	Protective Gloves	Wear heat resistant gloves.
	Protective Face or Eye Wear	Wear face shield or safety glasses.
	Body Crush Hazard	Do not stand between trailer and hitch when hooking equipment to truck.

Chapter 2 Safety

Table 2-2 Safety Symbols and Notices (continued)

Symbol	Item	Remark
	Crush Hazard	Keep feet and legs clear.
	Pinch Hazard	Keep hands and feet clear.
	Exhaust Hazard	Avoid breathing engine exhaust.
	Read Manual	Read and understand operator and safety manuals before operating machine.

Chapter 3 Warranty Information

3.0 Limited Warranty

Crafco, Inc. (Manufacturer), or one of its affiliated distributors, will replace for the original purchaser free of charge any parts found upon examination by the Manufacturer, to be defective in material or workmanship. This warranty is for a period **two years** from the invoice date, but excludes engine or components, tires, and battery as these items are subject to warranties issued by their manufacturers.

Crafco, Inc. shall not be liable for parts that have been damaged by accident, alteration, abuse, improper lubrication/maintenance, normal wear, or other cause beyond our control.

The warranty provided herein extends only to the repair and/or replacement of those components on the equipment covered above and does not cover labor costs. The warranty does not extend to incidental or consequential damages incurred as a result of any defect covered by this warranty.

All transportation and labor costs incurred by the purchaser in submitting or repairing covered components must be borne by the purchaser. Crafco, Inc. specifically disavows any other representation, warranty, or liability related to the condition or use of the product.

CAUTION

Use of replacement parts other than genuine Crafco parts may impair the safety or reliability of your equipment and nullifies any warranty.

Chapter 3 Warranty Information

3.1 Warranty Claim Instructions

Crafco, Inc. warrants parts and machinery purchased through Crafco or one of its affiliated distributors for two years from the invoice date. Wear items are not covered under the Crafco, Inc. limited warranty. A wear item is defined as but not limited to: material pumps, sealing tips, tires, etc.

If parts fail to function within two years of invoice date, a return authorization number (RA) must be obtained. If the part was purchased through Crafco, Inc., please contact Crafco returns department at [Returns@Crafco.com](mailto>Returns@Crafco.com) for an RA number or if purchased through a Crafco distributor please contact your distributor.

Note: if the part has a serial number associated with it, for example; a machine or electric hose or wand, this must be furnished when requesting the RA number. The customer will be emailed or faxed an RA form with all instructions to return the item to Crafco, Inc. See example. If the part is found to be within the two year warranty period and has not been abused or modified, a credit will be issued to the customer's account or credit card. The customer may request the part be replaced instead of a credit, if desired.

Note: All engine warranties are covered through the engine manufacturer. If you need information for a distributor in your area, please contact us and we will direct you to the closest engine distributor.

All parts returned are tested and evaluated. If the part has been modified in any way without prior consent from a Crafco, Inc. representative, warranty is void.

Please follow the instructions stated below when calling in a Warranty Claim. Failure to follow these procedures may be cause to void the warranty.

Call your local Crafco Distributor. If you do not know who your local distributor is, call a Crafco Customer Service Representative, (Toll Free 1-800-528-8242) for name, location and telephone number.

On contacting the distributor, be prepared to identify the serial number, model number, engine number, engine manufacturer, and the date of purchase if available.

Should the cause of the malfunction be a defective part, the Distributor will advise you of the procedure to follow for a replacement.

The warranty is valid only for parts which have been supplied or recommended by Crafco, Inc.

If you have any additional questions regarding warranty repairs and parts, please do not hesitate to call toll free 1-800-528-8242.

For Warranty:

Crafco, Inc.
25527 South Arizona Avenue, Chandler, AZ
85248
Phone: (480) 655-8333 or (800) 528-8242
Fax: (480) 655-1712

For all other inquiries:

Crafco, Inc.
6165 W Detroit Street
Chandler, AZ 85226
Phone: (602) 276-0406 or (800) 528-8242
Fax: (480) 961-0513
CustomerService@crafco.com

Chapter 4 Machine Specifications

4.0 Machine Specifications

Table 4-1 Machine Specifications

Specification	PN 93140K, 550 TRAILER	PN 93142K, 700 TRAILER
Tank Capacity	550 Gal	700 Gal
Overall Dimension	20' x 84" x 73"	20' x 84" x 83"
Drive Mechanism	Hydraulic with infinite adjust	
Agitator	1-1/2" shaft, 4-paddle, full sweep, reinforced rubber wiper each	
Bearings	1-1/2" 4-bolt pillow block	
Shaft Seal	1-1/2" rotary shaft seal, nitrile	
Hydraulic Tank	7.3 Gal. (27.6 L)	
Air compressor tank	Rolair 30 Gal tank	
Material Pump	1-1/2" diaphragm pump	
Material Pump Capacity	130 gpm @ 125 psi (max.)	
Strainer Basket	1.5" NPT, 3-gallon capacity	
Gas Engine	13 HP Honda, electric start	
Fuel Tank Capacity	1.4 Gal. (5.3 L)	
Air Compressor	Stationary gas powered, 30-gallon 8.7 – 33.7 CFM two-stage pump	
Hose	3/4" 300 psi – 100' length	
Dry Weight Approximately	4,100 Lbs.	4,250 Lbs.
Axle Capacity	Dual 6000 lbs.	Dual 6000 lbs.
Tires	3,520 lb capacity each (load range E), 80 psi cold inflation	

Chapter 4 Machine Specifications

4.1 Tank Depth Charts

Table 4-2 Seal Coater 550 Tank Depth Chart

Sealcoater 550		
INCHES OF VOID	GALLONS REMAINING	LITERS REMAINING
1	561.16	2123.99
2	555.98	2104.38
3	549.34	2079.25
4	541.57	2049.84
5	532.85	2016.84
6	523.33	1980.80
7	513.09	1942.05
8	502.23	1900.94
9	490.81	1857.72
10	478.89	1812.60
11	466.52	1765.78
12	453.75	1717.44
13	440.62	1667.75
14	427.17	1616.84
15	413.43	1564.83
16	399.44	1511.88
17	385.23	1458.10
18	370.83	1403.59
19	356.27	1348.48
20	341.57	1292.84
21	326.77	1236.82
22	311.90	1180.54
23	296.97	1124.03
24	282.01	1067.41
25	267.05	1010.78
26	252.12	954.27
27	237.24	897.95
28	222.44	841.94
29	207.75	786.33
30	193.19	731.22
31	178.79	676.72
32	164.58	622.94
33	150.59	569.98
34	136.85	517.98
35	123.40	467.07
36	110.27	417.37
37	97.50	369.04

Chapter 4 Machine Specifications

Table 4-3 Seal Coater 550 Tank Depth Chart (continued)

Seal Coater 550		
INCHES OF VOID	GALLONS REMAINING	LITERS REMAINING
38	85.13	322.22
39	73.21	277.10
40	61.79	233.88
41	50.93	192.77
42	40.69	154.01
43	31.17	117.98
44	22.45	84.97
45	14.68	55.56
46	8.04	30.43
47	2.86	10.83

Chapter 4 Machine Specifications

Table 4-4 Seal Coater 700 Tank Depth Chart

Sealcoater 700		
INCHES OF VOID	GALLONS REMAINING	LITERS REMAINING
1	710.80	2690.38
2	705.29	2669.52
3	698.95	2645.53
4	689.95	2611.46
5	680.66	2576.30
6	670.48	2537.77
7	659.53	2496.32
8	647.89	2452.26
9	635.63	2405.86
10	622.82	2357.37
11	609.50	2306.96
12	595.72	2254.80
13	581.52	2201.05
14	566.95	2145.91
15	552.03	2089.43
16	536.80	2031.79
17	521.30	1973.12
18	505.54	1913.47
19	489.57	1853.02
20	473.40	1791.82
21	457.07	1730.01
22	440.59	1667.63
23	423.99	1604.80
24	407.31	1541.67
25	390.55	1478.23
26	373.74	1414.61
27	356.92	1350.94
28	340.09	1287.24
29	323.29	1223.65
30	306.53	1160.22
31	289.84	1097.04
32	273.25	1034.25
33	256.77	971.87
34	240.43	910.03
35	224.27	848.86
36	208.29	788.38
37	192.54	728.76

Chapter 4 Machine Specifications

Table 4-5 Seal Coater 700 Tank Depth Chart (continued)

Seal Coater 700		
INCHES OF VOID	GALLONS REMAINING	LITERS REMAINING
38	177.03	670.06
39	161.81	612.45
40	146.89	555.98
41	132.31	500.79
42	118.12	447.08
43	104.34	394.93
44	91.02	344.51
45	78.20	295.99
46	65.94	249.58
47	54.31	205.56
48	43.36	164.12
49	33.18	125.59
50	23.88	90.39
51	15.60	59.05
52	8.54	32.32
53	3.04	11.51

Chapter 5 Operating Instructions

5.0 Operating Instructions

The Crafco Sealcoater 550 or 700 is designed to give excellent service and save maintenance expense. However, as with all specifically engineered equipment, you can get the best results at minimum cost if you operate your machine as instructed, and maintain it regularly as instructed in this manual.

Note: DO NOT attempt to operate the machine without using these and all other instructions.

5.1 Preparing the Machine for Start Up

Your Crafco Sealcoater 550 or 700 is serviced and tested prior to shipment. However, shipping regulations do not allow shipment of a fully serviced unit. The following should be checked prior to operation:

Table 5-1 Preparing the Machine for Start Up

Step	Action
1	Fill gasoline fuel tank located on the air compressor unit.
2	Check oil sight gauge daily for the air compressor pump. Add if required. Read the compressor manufacturer's manual supplied with the unit for maintenance.
3	Check engine oil level daily. Add if required.
4	Check oil level daily. Add if required
5	Inspect the compressor's air intake filter.
6	Visually inspect belts and pulleys. Look specifically for setscrews on sprockets, ensuring they are tight.
7	Drain condensation (water) from the air tank.
WARNING	
	<p>The safe operation of this machine is the operator's responsibility. Use extreme care when operating this machine; safety is the result of being careful and paying attention to details.</p> <p>Always put on protective clothing, gloves, hard-soled shoes, and safety glasses or a face shield. Be sure that all joints and fittings are tight and leak proof. Immediately replace any hose, which shows any signs of wear, fraying, or splitting. Tighten all bolts, nuts, and screws every 100 hours.</p>

Chapter 5 Operating Instructions

5.2 Locations of Valves and Controls



Figure 5-1 Sealcoater Valves and Water Hose (See detail view next page.)

Chapter 5 Operating Instructions

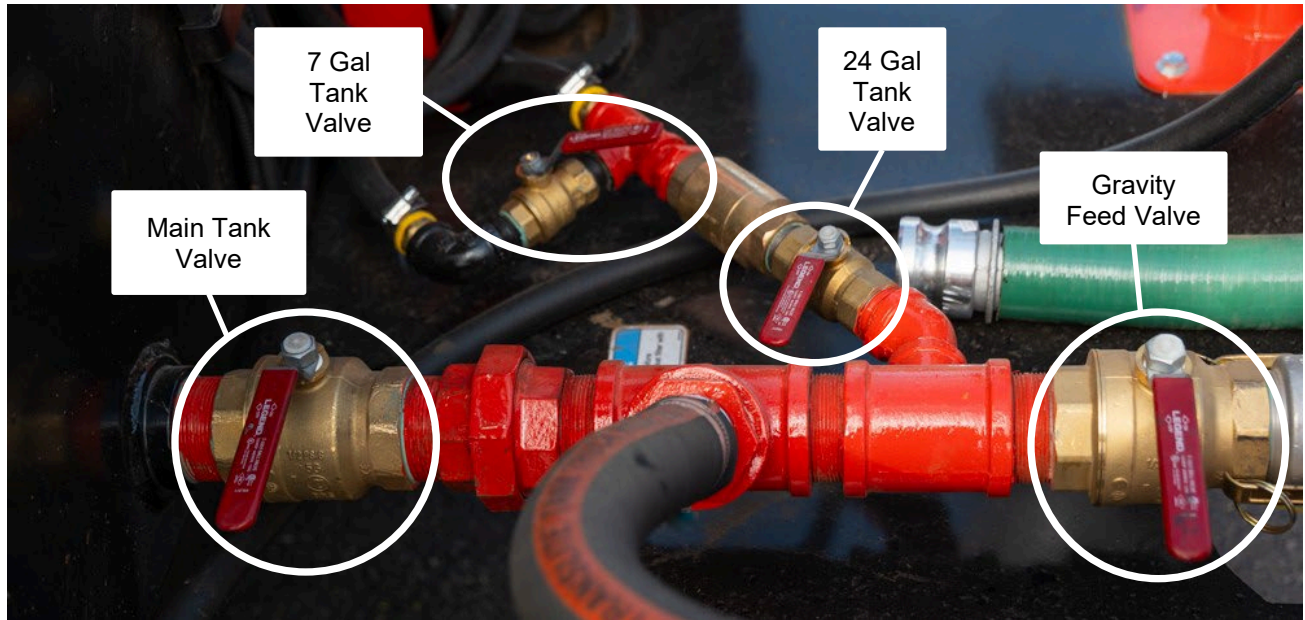

Figure 5-2 Sealcoater Valves and Water Hose

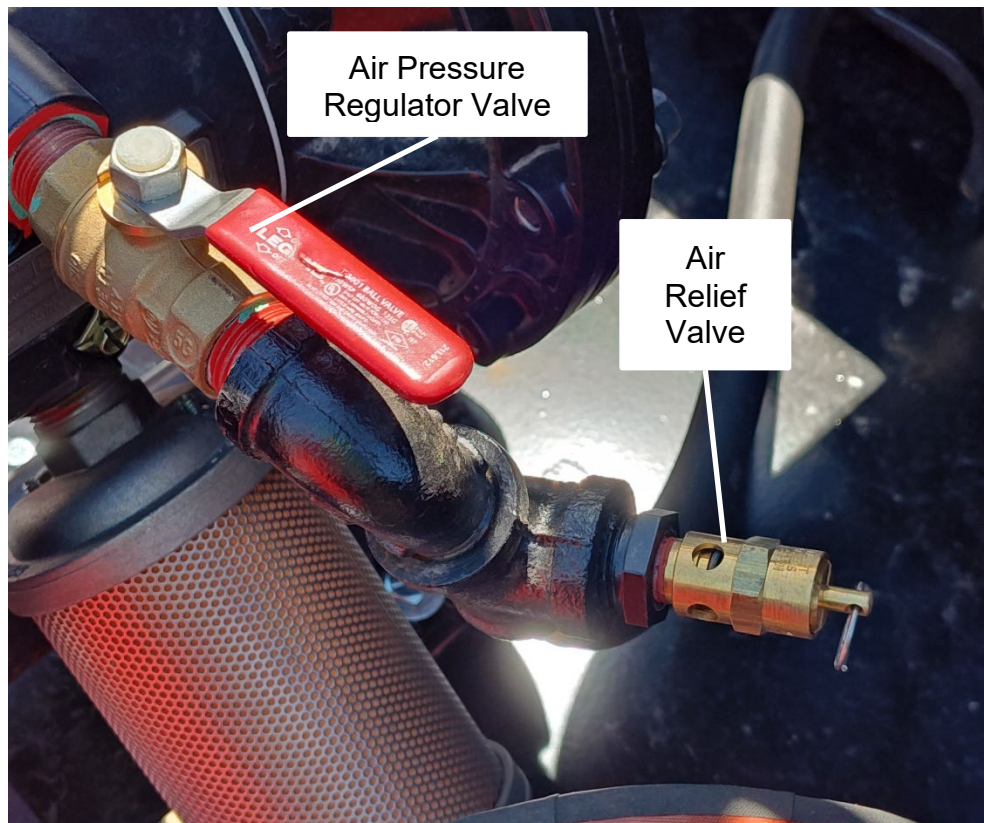

Figure 5-3 Sealcoater Valves and Water Hose

Chapter 5 Operating Instructions

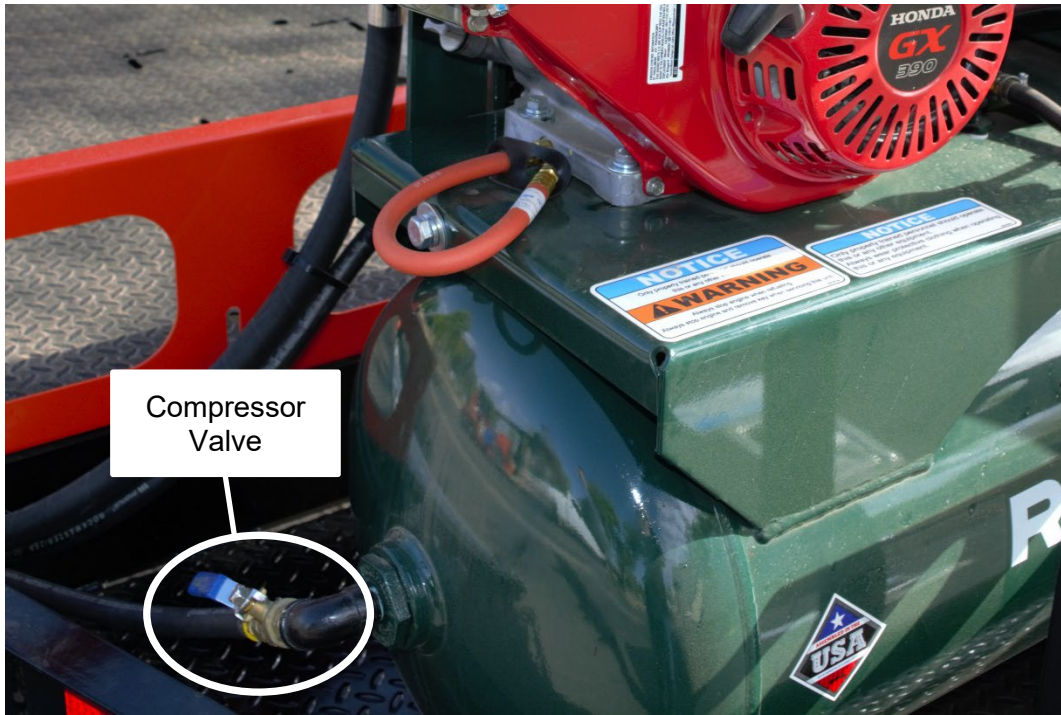

Figure 5-4 Air Compressor Valve

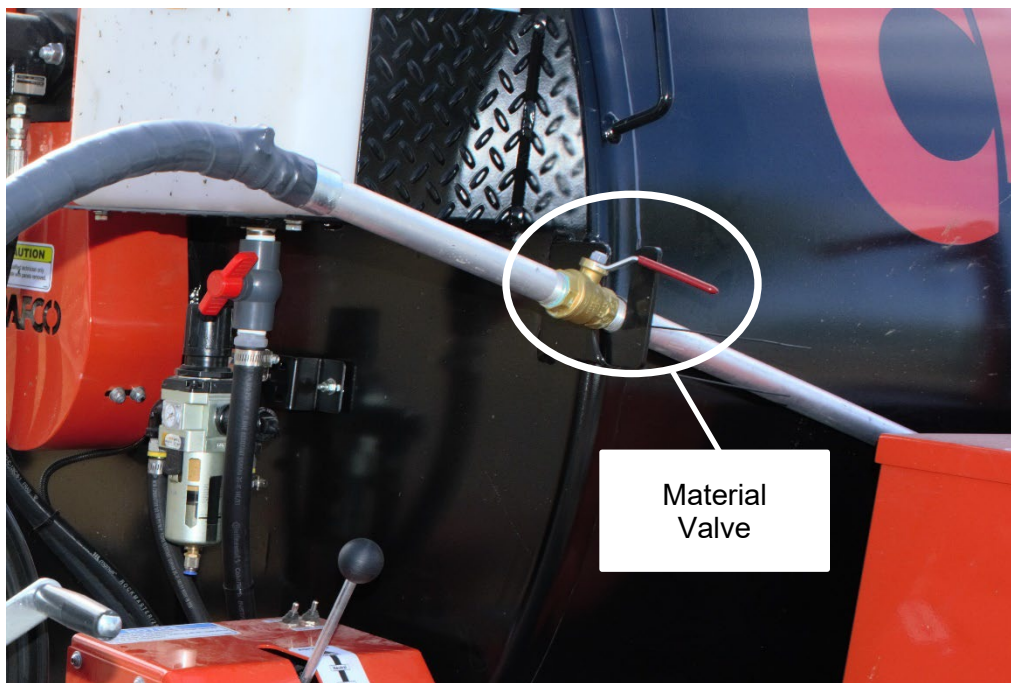

Figure 5-5 Material Valve

Chapter 5 Operating Instructions

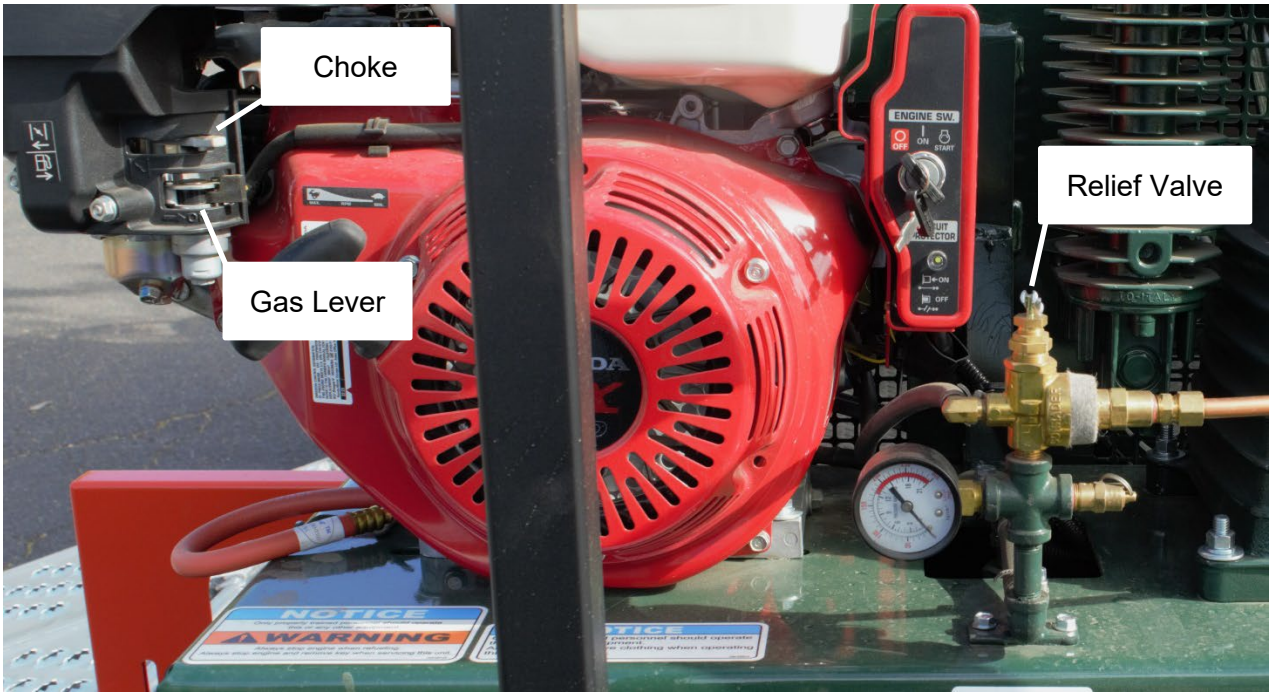

Figure 5-6 Air Compressor Engine



Figure 5-8 Agitation Control



Figure 5-7 Hydraulic Flow Control

Chapter 5 Operating Instructions

5.3 Machine Start Up

Table 5-2 Machine Start Up

Step	Action
1	Make sure all material, air, and water valves are in the closed position.
2	Make sure the hydraulic flow valve is in the neutral position.
3	Open the relief valve on the compressor unit. This unloads the pressure on the heads of the compressor pump.
4	Move the grey choke lever on the compressor engine to the right, to the CHOKE (closed) position.
5	Move the black gas lever on the compressor engine to the ON position.
6	Turn the ignition key on the compressor engine to the START position. When the engine turns over and begins running, slide the grey choke lever from the CHOKE position to the OPEN position by moving it left.
7	Close the relief valve on the compressor unit.
8	Let the compressor unit run until it idles down. When this happens, the air tank is full and ready for operation.

5.4 Operating the Compressor

The compressor is the power source to operate the air-operated diaphragm pump (spray system) as well as the hydraulic agitation system.

Step	Action
1	Start the compressor and let it run until it automatically unloads. Pressure should range from 150 to 175 psi.
2	Turn off the engine and open the air pressure regulator valve to allow air to the regulator.
3	Inspect for air leaks using soap and water if necessary.

5.5 Operating the Hydraulic Agitator

Step	Action
1	Make sure the compressor unit engine is running.
2	Engage the hydraulic directional lever up to move the agitator in a clockwise rotation or down to move the agitator in a counterclockwise rotation.
3	Move the hydraulic flow control lever forward to allow the hydraulic motor to turn. The agitator speed is determined by the position of the handle.
4	To stop the agitator, return the hydraulic flow control lever to the neutral position.
5	Return the hydraulic directional lever to the neutral position.

Chapter 5 Operating Instructions

5.6 Operating the Pump

It is recommended that new users gain familiarity with the pump and spray system before attempting to apply sealcoat at a jobsite. Fill the tank with approximately 25 to 50 gallons of water and operate through all typical jobsite settings.

Step	Action
1	Start the compressor and allow the unit to fill with air.
2	Open the air pressure regulator valve to send air to the air regulator at the rear of the unit.
3	Open the main tank valve to allow water into the strainer basket.
4	Open the recirculation/return to tank valve to allow water to the tank.
5	Adjust the air pressure on the air pressure regulator to 40 psi.
6	Open the air supply valve to allow the air diaphragm pump to operate. You will hear the pump stroke back and forth.
7	Close the recirculation/return to tank valve. The pump will come to a stop.
8	Spool out a length of hose that allows you to safely spray water onto the ground, into a bucket, or similar.
9	Ensure there is no plug or obstruction in the end of the spray wand.
10	Install a spray tip into the end of the spray wand to help you evaluate the spray pattern.
11	Open the hose reel valve to send water to the hose reel and spray hose.
12	Slowly open the spray wand valve. The air diaphragm pump will stroke and water will begin to spray out of the wand.
13	Close the spray wand valve to stop pumping and spraying.
14	Increase the air pressure on the air pressure regulator to 60 psi and repeat the spray process. Notice the change in spray pattern at the increased pressure.
15	Close the spray wand valve. Increase the air pressure setting to 80 psi and repeat the process. Notice the change in spray pattern at the different pressure settings.
16	Remove the spray tip and put it into a sealed plastic container with water. Install a plug into the fitting at the end of the spray wand.
17	Reel the hose back onto the spool and store the spray wand.
18	Close the hose reel valve.
19	Open the recirculation/return to tank valve to 1/2 open position when the system is not in use to allow natural pressure buildup caused by temperature changes to relieve to the tank.
20	Turn off the engine on the compressor.
21	Open the tank drain on the bottom of the compressor when not in use.

Chapter 5 Operating Instructions

5.7 Loading Material into the Tank

CAUTION

These steps assume that valves are closed, the air compressor is running, the air tank is full, and strainer box lid is tightened down.

Table 5-3 Loading Material Using the On Board Material Pump

Step	Action
1	Prior to loading the tank, ensure the gravity feed valve is closed so sealer does not disperse onto the ground.
2	Determine if the sealer is concentrated or ready to use.
3	Consult your sealcoat supplier for safety regulations and specifications for the sealcoat that you will be applying.
4	When adding sand, ensure the tank's agitation is on but rotating slowly (5 rpm or less).
5	Engage the hydraulic directional lever for forward or reverse.
6	Slowly increase the flow of hydraulic fluid at the hydraulic flow control lever to increase power and speed. The hydraulic flow control is typically set at speed #2 on the valve body.
8	Pump material into tank until desired level is reached.
9	Close all valves.

5.8 Agitating the Material

Table 5-4 Agitating the Material

Step	Action
1	Make sure the compressor unit engine is running.
2	Engage the hydraulic metering valve up to move the agitator in a clockwise rotation or down to move the agitator in a counterclockwise rotation. The agitator speed is determined by the position of the handle. The more the handle is moved away from the neutral position the faster the agitator will turn.
3	To stop the agitator, return the hydraulic valve to the neutral position.

Chapter 5 Operating Instructions

5.9 Recirculating the Material

Table 5-5 Recirculating the Material

Step	Action
1	Set the air pressure regulator to the desired pressure. 40 psi is recommended. Never exceed 125 psi.
2	Open the main tank valve.
3	Open the recirculation/return to tank valve.
4	Open the air pressure regulator valve.
5	When finished, close all valves.

5.10 Applying Material with the Hand Wand

Table 5-6 Applying Material with Hand Wand

Step	Action
1	Set the air regulator to the desired pressure.
2	Open the main tank valve.
3	Open the hose reel valve.
4	Open and close material valve to control the spray out of the hand wand.
5	When finished, close all valves.

Chapter 5 Operating Instructions

5.11 Flushing Material Hose and Hand Wand Using the Water Tank

Clean out the material hose and wand after every use. Follow the steps below starting with all valves in the closed position.

Table 5-7 Cleaning out Material Hose and Hand Wand

Step	Action
1	Return the hydraulic directional lever and the hydraulic flow control lever to the neutral position.
2	Open the main tank valve.
3	Set the air pressure regulator to 40 psi.
4	Stick the spray nozzle end of the spray wand into the material tank.
5	Open water inlet valve.
6	Open the hose reel valve.
7	Open the air pressure regulator valve.
8	Insert the spray nozzle end of the spray wand into a bucket.
9	Open the spray wand valve and spray into material tank until water comes out of the spray wand.
10	When finished, close all valves, remove the spray tip from the spray wand, and insert a pipe threaded plug. Spool the hose and return the spray wand to the secured travel position.

5.12 Draining Material Tank

Table 5-8 Draining Material Tank

Step	Action
1	Remove cam lock cap and attach a 1.5" hose to the cam lock fitting just in front of material valve.
2	Open the main tank valve.
3	Let material tank drain.
4	When finished close all valves and replace cam lock cap.

Chapter 5 Operating Instructions

5.13 Shutting Down the Machine

This procedure should only be done after cleaning the hose and wand.

CAUTION

When storing mixed sealcoat for two or more days, it is recommended to agitate the stored sealer in the tank daily for 15 minutes or longer at slow speed (5 rpm).

Table 5-9 Shutting Down the Machine

Step	Action
1	Return the agitator control valve to the neutral position.
2	Turn the ignition key on the compressor unit to the off position.
3	Move the black gas lever on the compressor engine, located just below the grey choke lever to the off position.
4	Drain the air from the compressor unit tank by opening air tank drain.
5	Wind up the hand wand hose and lock hose reel. Ensure the pedestal handle lock located under the hose reel is tightened before travel.
6	Remove the spray tip from the spray wand and insert a pipe threaded plug into the end of the spray wand.
7	Return hand wand to hand wand storage tab. Place the nozzle end of wand into drip tube.
8	Lock hand wand into storage tabs.
9	Return all equipment to storage deck and secure before travel.
10	Lock storage deck ramp in the up position. Ensure the ramp is secured before travel.
11	Close all valves on the machine.

Chapter 6 Maintenance Instructions

6.0 Maintenance Instructions

This chapter contains all normal maintenance instructions to properly maintain your machine.

6.1 Engine

Refer to the manufacturer's operating and maintenance instructions for the engine.

For an online PDF manual, visit <https://engines.honda.com/models/series/gx>.

6.2 Compressor

Refer to the manufacturer's operating and maintenance instructions for the compressor. For an online PDF manual, visit <https://www.rolair.com/air-compressors/stationary-gas-air-compressors>.

6.3 Hydraulic System

Check hydraulic fluid daily. Fill as necessary with AW46 hydraulic fluid. Change hydraulic **filter** every 250 hours of machine operation. Change hydraulic **fluid** every 500 hours of operation.

6.4 Material Pump 1.5"

Refer to separate manual in packet. For an online PDF manual, visit <https://www.graco.com/us/en/in-plant-manufacturing/product-group/husky-1590-air-operated-double-diaphragm-pump.html#specs>.

6.5 Battery Charger

Refer to the manufacturer's operating instructions. For an online PDF manual, visit <https://no.co/genpro10x1/how-to>

6.6 Lug Nuts

Torque all nuts/bolts before first road use and after each wheel removal. Check and torque after the first 10 miles, 25 miles, and again at 50 miles. Check periodically thereafter.

Torque in stages as follows:

First stage 20-25 foot-pound (ft-lb)

Second stage 50-60 foot pound (ft-lb)

Third stage 90-120 foot pound (ft-lb)

Tighten bolts and nuts in the sequence shown below.

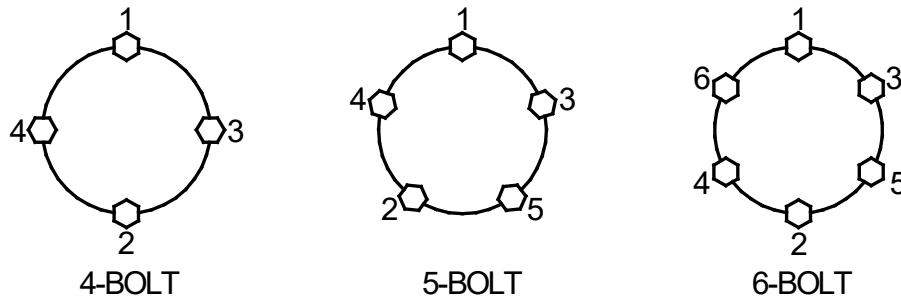

Figure 6-1 Lug Bolt Tightening Sequence

Chapter 6 Maintenance Instructions

6.7 Brakes

Check the brakes daily.

6.8 Tongue Jack

Lubricate the tongue jack, using a good grade of bearing grease.

6.9 Agitator Drive Chain Tension

Check the chain tension while doing hydraulic oil service every 250 hours of machine operation. The agitator drive chain should have 1/4" of deflection on the center of the chain. See [Figure 6.2 Agitator Drive Chain Tension](#). Follow the steps in [Table 6-1](#) to adjust the tension.

Table 6-1 Agitator Drive Chain Tension Adjustment

Step	Action
1	Loosen the 4 screws on the sides of the hydraulic motor adjustment bracket (See item 6 in Figure 8.11 Agitator Drive Chain).
2	Use two 3/8-16 jack screws in the top two holes of the bracket to adjust its position.
3	Measure the deflection in the chain halfway through its distance. See Figure 6.2 below.
4	Once there is 1/4" of deflection, retighten the 4 mounting screws on the sides of the bracket, and remove the jack screws.

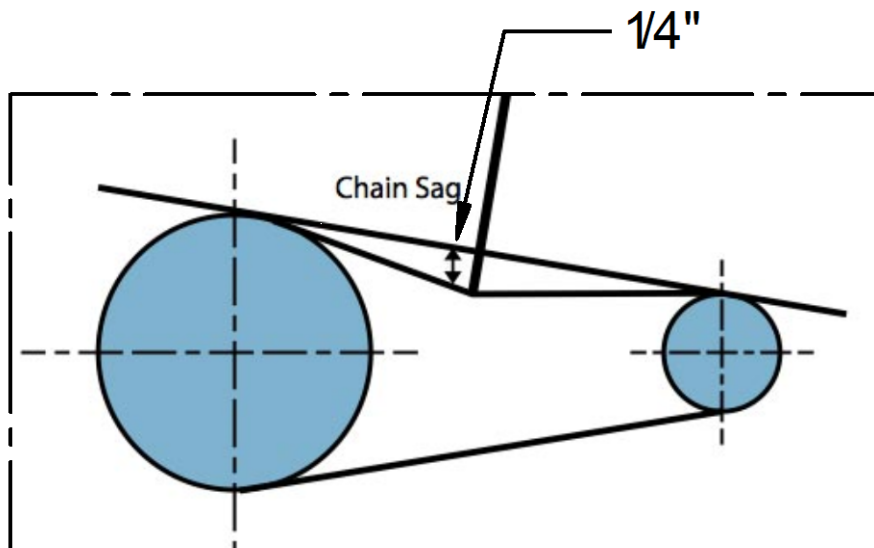

Figure 6-2 Agitator Drive Chain Tension

Chapter 6 Maintenance Instructions

6.10 Cleaning the Sealcoater

We recommend using Orange-Sol industrial cleaner for cleaning the exterior of the machine. Here is the website for the cleaner; <https://www.orange-sol.com/industrial-formula/>.

6.11 Maintenance Chart

Table 6-2 Maintenance Chart

Part	Procedure	Hours			
		8	100	250	500
Engine Check Oil Level	Refer to the manufacturer's instructions for the engine	X			
Other Engine Maintenance	Refer to the manufacturer's operating and maintenance instructions for the engine.				
Hydraulic Oil – Use AW46	Check	X			
	Change				X
Hydraulic Oil Filter	Change			X	
Agitator Drive Chain Tension	Check			X	
Wheel Bearings	Clean and re-pack using a good grade of bearing grease	Every 24,000 miles or two years			
Tongue Jack	Grease using a good grade of bearing grease	Once a year			
Material Tank	Scrape out built up material in the material tank	Once a year or as needed			
Compressor Air Filter Element	Check and Clean element weekly.	Replace every 6 months or sooner when necessary.			

Chapter 6 Maintenance Instructions

6.12 Daily Preventative Maintenance (Continued on next page.)

Item	Task(s)
Trailer	<p>NOTICE: Service any worn or loosened components or hardware.</p> <ul style="list-style-type: none"> • Inspect the hitch and hitch hardware. • Inspect the safety chain. • Inspect the safety brake away connection and battery. • Inspect the tires for fatigue and wear. • Torque wheel lugs. • Inspect the trailer frame and components for fatigue. • Connect the tow vehicle and ensure the trailer brakes operate correctly. • Inspect all lighting and ensure it operates correctly and that lights are visible.
Hydraulic Fluid	<ul style="list-style-type: none"> • Ensure hydraulic fluid level is 3/4 full in reservoir. Do not overfill. • Inspect return line spin-on filter.
Compressor	<ul style="list-style-type: none"> • Check oil in compressor. • Inspect compressor air filter. • Check engine oil. • Inspect engine air filter. • Visually inspect belts and pulleys. Specifically, look for setscrews on sprockets and ensure they are tight. • Drain water from compressor tank and retighten the tank drain. • Close the ball valve on the compressor outlet. • Engage the compressor unloader valve and start the engine. Allow the compressor to build pressure until it automatically reduces engine speed to idle. Tank pressure should range from 150-170 psi. • Turn off the engine and inspect for air leaks. Use soap and water solution if necessary. • Open ball valve to allow air to the regulator at the rear of the unit. • Inspect for air leaks throughout the entire air system.
Plumbing and Hoses	<ul style="list-style-type: none"> • Thoroughly inspect all fitting connections and hose connections. • Inspect and torque all hose clamps as needed. • Inspect and torque all hydraulic fittings as needed. • Inspect all pipe fittings. Pipe fittings (the plumbing) normally should not loosen, as they are interconnected and secured. If a fitting is discovered to be loose, consult a trained factory representative for service recommendation. • Unspool the spray hose and inspect for exterior wear and tear, especially at areas that drag on the parking lot during sealcoat application. Replace if any noticeable fatigue is shown on the hose.

Chapter 6 Maintenance Instructions

Strainer Basket	<ul style="list-style-type: none"> • Ensure the main tank valve is in the CLOSED position. • Ensure the air supply valve is in the CLOSED position and the recirculation/return to tank valve is in the OPEN position. • Ensure the air regulator pressure is set to 40 psi. • Move the air supply valve to the OPEN position. Allow pump to stroke for 5 seconds, then move the air supply valve to the CLOSED position. This will lower the fluid level in the strainer basket. • Remove the strainer basket lid. • Install the accessory fill hose onto the main drain quick coupling. • Slowly move the main drain valve to the OPEN position to relieve suction pressure in the strainer basket. • Collect any fluid that drains from the hose end in a bucket. NOTICE: Be careful not to damage the rubber gasket. • Inspect and clean the strainer basket as necessary. • Reinstall the lid after cleaning the strainer basket. Tighten hand-tight.
Agitation	<p>NOTICE: Mixed sealcoat with additives and sand will settle.</p> <ul style="list-style-type: none"> • Start the engine on the compressor. • Engage the hydraulic flow agitator lever. Slowly engage the hydraulic flow control valve (position #2) to begin agitating. • Allow the agitation to rotate at slow rpm for 10 minutes. <p>NOTICE: It is recommended to agitate the sealcoat mixture slowly during application.</p>

Chapter 6 Maintenance Instructions

6.13 Annual Preventative Maintenance

Item	Task(s)
Hydraulic Fluid	Change filters and fluid. Use AW46 hydraulic fluid.
Clean Tank, Plumbing, and Pump	<p>Flush the interior of the sealcoat unit with clean water at the end of the work season before storage. Fill the tank with 50 to 100 gallons of water and operate the agitation in both directions.</p> <ul style="list-style-type: none"> • Pump the water through the hose and the spray wand. • Pump the water through the recirculation/return to tank valve. • Clean the strainer filter basket. <p>NOTICE: It is necessary to drain all water from the tank and plumbing system if the unit will be stored in a freezing environment.</p>

6.14 Winterizing

CAUTION

Sealcoat is a water-based emulsion. Allowing sealcoat to freeze in your sealcoat tank, plumbing, and application system will permanently damage many components. **It is necessary to drain all water from the tank and plumbing system if the unit will be stored in a freezing environment.** Damage from freezing is not warrantable.

Environmentally compatible RV & marine antifreeze can be used in the system to help prevent freezing.
NOTICE: Consult local codes along with the product manufacturer for proper disposal of used antifreeze.

6.15 Service Instructions

Table 6-3 Service Instructions

Step	Action
1	Do a general inspection of the machine at least once a week.
2	<p>Replace all worn or damaged parts.</p> <p>Note: Keep regular replacement items in stock for emergency repairs to prevent costly downtime.</p>
3	Make necessary adjustments and tighten all loose nuts or screws.
4	Watch for leaks. Tighten fittings or repair as necessary.
5	Clean the external surfaces of the machine at regular intervals.
6	Follow the recommended maintenance per Table 6-2 Maintenance Chart

For service, find a list of authorized Distributors and service centers at Crafco.com/Distributors.

Chapter 6 Maintenance Instructions

6.16 General Maintenance Parts

Table 6-4 General Maintenance Parts

Description	Part Number
3 Gallon Strainer Pot	CR300001
3 Gallon Strainer Basket-1/4" Perforation	CR300002
3 Gallon Strainer Basket-3/16" Perforation	CR300003
3 Gallon Strainer Basket-1/8" Perforation	CR300004
1/4" 80 Degree Spray Tip-3 GPM	CR300005
1/4" 80 Degree Spray Tip-1 GPM	CR300006
1/4" 80 Degree Spray Tip- 4 GPM	CR300007
1.5" Graco Air Diaphragm Pump	CR300008
2 5/16" Adjustable Tongue Coupler	CR300009
Spare Tire- ST235/80R16-Tire and Rim-Loose	CR300010
Spare Tire- ST235/80R16-Tire and Rim-Mounted	CR300011
Trailer Plug Assembly-7 Way Flat	CR300012

6.17 Recommended Fluids and Lubricants

Table 6-5 Recommended Fluids and Lubricants

Application	Recommended
Engine Oil	Refer to engine manual
Hydraulic Oil	Shell AW Hydraulic 46
Compressor Oil	Single viscosity, non-detergent compressor oil.

Chapter 6 Maintenance Instructions

6.18 Ordering Parts

Crafco distributors and Crafco Pavement Preservation Supply Centers are strategically located throughout the United States. Parts can be ordered from your local Crafco distributor or directly from Crafco, Inc. if a distributor is not available in your area.

When ordering parts, give the following information:

- Part Number or Description
- Machine Model
- Serial Number

Write, call, or Fax Crafco, Inc. at the following:

Crafco, Inc. Headquarters
6165 W Detroit St.
Chandler, AZ 85226
Phone: (602) 276-0406
Toll Free: (800) 528-8242
Fax: (480) 961-0513

Visit our website at www.crafco.com

Chapter 7 Troubleshooting

7.0 Troubleshooting

WARNING

Relieve all pressure in the system before checking or servicing the equipment.

Check all possible problems and causes before disassembling the pump.

7.1 Pump Troubleshooting

Problem	Cause	Solution
Pump cycles at stall or fails to hold pressure at stall.	Worn or damaged valve balls or valve seats.	Clean or replace.
Pump will not cycle, or cycles once and stops.	Air valve is stuck, dirty, or worn.	Disassemble and clean air valve. Use filtered air or install air kit to rebuild air side of pump.
	Check valve ball severely worn and wedged in seat or manifold.	Replace ball and seat.
	Check valve ball is wedged into seat due to over-pressurization or vacuum due to inlet valve being closed.	Replace check balls and valve seat. Ensure inlet valves are open.
	Pumps inlet or discharge piping is clogged.	Relieve pressure and clear valve.
Pump operates erratically.	Clogged suction line.	Inspect; clear.
	Sticky or leaking valve balls.	Clean or replace.
	Diaphragm ruptured.	Replace.
	Restricted exhaust.	Remove restriction.
Air bubbles in fluid.	Suction line is loose.	Tighten.
	Diaphragm ruptured.	Replace.
	Loose inlet manifolds, damaged seal between manifold and seat, damaged O-rings.	Tighten manifold bolts or replace seats or O-rings.
	Loose diaphragm shaft bolt.	Tighten or replace.
	Damaged O-ring.	Replace.
Fluid in exhaust air.	Diaphragm ruptured.	Replace.
	Loose diaphragm shaft bolt.	Tighten or replace.
	Damaged O-ring.	Replace.



Chapter 7 Troubleshooting

Problem	Cause	Solution
Pump exhausts excessive air at stall.	Worn air valve block O-ring, plate, pilot block u-cups, or pilot pin o-rings.	Install air kit to rebuild air side of pump.
	Worn shaft seals.	Replace.
Pump leaks air externally.	Air valve cover or air valve cover screws are loose.	Tighten screws.
	Air valve gasket or air cover gasket is damaged.	Inspect; replace.
	Air cover screws are loose.	Tighten screws.
Pump leaks fluid externally from ball check valves.	Loose manifolds, damaged seal between manifold and seat, damaged O-rings.	Tighten manifold bolts or replace seats or O-rings.



7.2 Air Compressor Troubleshooting

Problem	Cause	Solution
Compressor doesn't produce enough air.	Incorrect pump up time.	<ul style="list-style-type: none"> · Drain air tank and measure pump up time. Compare with proper time for compressor model (see factory guide). · If time is okay, compressor may be too small for application. Increasing operating pressure will exaggerate the problem.
	Leaks in air lines, tank, or compressor fittings.	Test for leaks in air lines, tank, or compressor fittings. A soap suds solution works well.
	Clogged air filter element.	Remove, clean, or replace air filter element. Intake air must be free of contamination such as paint mist.
	If hot air blows out of intake, intake valves are not sealing.	Remove and clean intake valves. Polish disc using a fine emery cloth (#400). Replace worn parts. A complete valve plate assembly can be obtained as a factory exchange at a low cost.
	Clogged check valve or discharge tubing.	Clean or replace.

Chapter 7 Troubleshooting

Air leaks from centrifugal unloader (EQ74B).	 <p>NOTICE: To provide “loadless starting,” the unloader opens the air valve (EQ74A) when the compressor stops, bleeding off air contained between the compressor and the tank check valve.</p>	
	Tank check valve leaks.	If air leaks continuously when the compressor stops, the tank check valve is leaking. Drain tank. Remove and repair the check valve.
	Air release needs adjusting.	<ul style="list-style-type: none"> · If air leak is steady when the compressor runs, adjust air release. · Remove tube from EQ76. · Loosen lock nut EQ74C. · Turn the unloader out one turn counterclockwise. The valve should seal when running and open when stopped. · Repeat adjustment if necessary.
Excessive oil consumption.	<p>NOTICE: Measure oil consumed per hour of operation. </p>	
	Clogged air intake filter.	Clean or replace.
	Inferior or dirty oil.	See recommendations in instructions.
	Crankcase isn't sealed, so air leaks in.	<ul style="list-style-type: none"> · Check oil fill cap and shaft oil seal. Replace if necessary. · Tighten crankcase bolts to 15 ft-lb.
	Piston rings are worn or sticking.	<ul style="list-style-type: none"> · Remove piston rings and clean the grooves. · Check ring wear by pushing the ring into the cylinder bore. · The new ring end gap is approximately .007 to .017 inches. (Operation is okay to .060.) Stagger ring gaps when installing.
	Deep scratch on cylinder wall, caused by lack of oil or dirt in oil.	Hone (.015 max. on diameter) or replace.
	Oil in discharge air. (Some oil is always present.)	Clean accumulation in air lines and tank. Add air line filter or clean element.
	Compressor unloaded more than 60% with constant running control.	Consider start-stop or dual control.

Chapter 7 Troubleshooting

Problem	Cause	Solution
Milky oil in reservoir.	NOTICE: This is the normal result of water mixing with oil in the tank or possibly in the crankcase. 	
	Water mixing with oil in the tank or crankcase.	<ul style="list-style-type: none"> · Change oil and/or drain cock. · Move compressor or pipe intake to lower the humidity source or cooler area. Increase the intake pipe one size for every 3 feet of length – keep the length short.
Noise, knock, or vibration.	Assembly vibrates.	See mounting instruction.
	Flywheel wobbles, indicating a cracked flywheel or bent shaft.	Replace the flywheel.
	Flywheel or pulley is loose.	Remove flywheel, apply Loctite on shaft, and reinstall with new key.
	Loose or worn connecting rod or piston pin.	Tighten or replace.
	Pressure switch or magnetic starter chatter.	Adjust switch for greater differential or replace.
	Loose vee belt.	Adjust tension on slotted platform.
	Foreign matter (such as carbon, dirt, or a piece of gasket) on top of the piston.	<ul style="list-style-type: none"> · Remove cylinder head and check for debris. · To increase head clearance, add crankcase gaskets instead of head gaskets.
Compressor runs hot.	WARNING: Head and discharge line normally are hot enough to burn if touched. 	
	Compressor operates in excess of rated discharge pressure.	Reset pressure control.
	Poor ventilation.	Provide a cooler location. Allow a minimum 6 in. flywheel clearance.
	Incorrect rotation.	Check flywheel arrow. Reverse motor.
	Discharge valve or head gasket leaks.	Remove and clean the discharge valve. Replace if necessary.
	Restriction in discharge line or check valve.	Clean or replace.

Chapter 7 Troubleshooting

Problem	Cause	Solution
Compressor slows down or freezes up.	Supply voltage doesn't match the motor (i.e., 115 volt supply with motor connected for 230 volts or 208 volt supply with 230 volt motor).	<ul style="list-style-type: none"> · Measure actual voltage at the motor while the compressor is under load (starting up or at high pressure). · If voltage is more than 10% below motor nameplate rating, move compressor closer to main switch panel and/or provide heavier wiring. Check with electric power company.
	Vee belt is slipping.	<ul style="list-style-type: none"> · Adjust tension by moving the motor. · Clean oil from belt and pulleys.
	Operating pressure is set higher than design pressure.	Reset control.
	Lack of oil.	If flywheel cannot be turned by hand (drain tank to eliminate back pressure), check oil level.
	Damaged compressor components.	<ul style="list-style-type: none"> · If "frozen" condition exists after cooling down and adding oil, disassemble compressor and replace damaged components. · After compressor "run in" period, freezing is caused by lack of adequate clean lubrication. <p>Perform the next step only for tanks with gas engine-driven compressors.</p> <ul style="list-style-type: none"> · If engine stalls during acceleration, increase engine idle speed. On engines equipped with a clutch, maintain idle speed below clutch engagement speed (approximately 1900 rpm).



© 2025 CrafcO, Inc.