



- **MODEL 30 PAVEMENT ROUTER MANUAL**
- **SELF-PROPELLED ROUTER**
- **DUST CONTROL ROUTER**

PART MANUAL - 21320
Rev. D

MODEL 30 PAVEMENT ROUTER



TABLE OF CONTENTS

MODEL 30 PAVEMENT ROUTER

Model 30 Pavement Router, Dust Control Router and Self-Propelled Router....	5
Safety Precautions.....	6
Limited Warranty.....	7
Warranty Claim Instructions.....	8
Contact Us.....	9
Specifications.....	10
Introduction.....	11
Operating Instructions for The Model 30 Pavement Router, Dust Control Router and Self-Propelled Router.	
Engine Operation Instructions.....	12-13
Operating Procedures.....	14-20
Storing the Machine.....	20
Maintenance for The Model 30 Pavement Router, Dust Control Router and Self-Propelled Router.	
Maintenance.....	21-23
Periodic Maintenance.....	23
Maintenance Schedule.....	24
Service and Maintenance Instructions.....	25-26
Changing Cutters.....	27-29
Changing Cutter Head.....	30-31
Installing New Cutter Head and Main Shaft.....	32
Changing V-Belts.....	33-34
Electric Clutch.....	34
Trouble-Shooting for The Model 30 Pavement Router, Dust Control Router and Self-Propelled Router.	
Trouble-Shooting Guide.....	35
Parts for The Model 30 Pavement Router	
Cutter Head Assembly Complete - Diagram and Parts.....	36-37
Pavement Cutter Selection.....	38
Cutter Installation Warning.....	39
Cutter Positioning.....	40-41
Model 30 Pavement Router Diagrams and Parts.....	42-47
Self-Propelled Router	
Drive Wheel Clutch Assembly.....	50-51
Self-Propelled Drive System.....	52-53
Self-Propelled Hub/Wheel Spacer.....	54
Engine Support Frame/Cable Bracket Holder.....	55
Dust Control Router	
Dust Collection Bag Maintenance.....	58
Parts List Cutter Head Dust Shroud.....	59
Parts List Dust Control.....	60-61

MODEL 30 PAVEMENT ROUTER

This manual is furnished with each new **CRAFCO MODEL 30 PAVEMENT ROUTER**. This manual will help your machine operators learn to run the machine properly and understand its mechanical functions for trouble-free operation.

Your **CRAFCO MODEL 30 PAVEMENT ROUTER** is designed to give excellent service routing pavement. There are two additional router models that maintain the high performance of the machine and improve worker safety.

The Dust Control Router:

- Meets EPA Visible Emissions Standards*
- Reduces dust by 96% vs. the standard model by emitting only 1.25% average dust opacity.
- Provides a cleaner working environment.
- Improves worker safety due to less dust, flying debris, and clear line-of-sight.
- Contains the debris path for easier clean-up, saving time and money.
- Extends life to the air filter and engine.

The Self-Propelled Router:

- Reduces worker fatigue by moving the router effortlessly from one distressed pavement area to another, and it works especially well on roads with inclines or hills.
- Reduces physical strain associated with loading and unloading the router onto a trailer during transport.

You can get the best results from this machine if:

- You operate your machine as instructed in this manual; and
- Maintain your machine regularly as stated in this manual.



WARNING:

The engine exhaust from this product contains chemicals known to the State of California to cause cancer, birth defects or other reproductive harm. Operate in well ventilated area only. Engine exhaust is deadly.



SAFETY PRECAUTIONS

MODEL 30 PAVEMENT ROUTER

1. Eye and ear protective devices along with a dust mask are required when operating the **CRAFCO MODEL 30 PAVEMENT ROUTER**.



2. Observe all **CAUTION AND WARNING** signs posted on machine.



3. Care should be taken when operating machine on grades. It is usually best to operate the machine going uphill, rather than downhill.
4. To stop or slow machine, push down on handle and/or release the clutch handle.
5. When cleaning cracks and joints near moving traffic, always move in a direction away from traffic to protect the operator.
6. Never allow fatigued operators to run the machine. Due to the nature of running this machine, the crew leader should rotate operators as they see fit according to their performance.
7. Tires should be inflated to 45 psi to allow machine to roll easily.
8. Never operate the router without belt guard in place.
9. Never transport the router with the engine running.
10. Never exceed maximum recommended engine RPM.
11. Never leave router unattended while engine is running.
12. Never stand on any part of the machine.
13. The only operating position is behind the pavement cutter with both hands on the handle.
14. Wear long pants, work gloves and heavy leather boots or shoes.
15. Tighten all bolts and screws every 100 hours of operations.



Include these Safety Precautions with the Dust Control Router

16. Do not operate router without hose attached to blower.
17. Do not operate router without hose attached to Cutter Head Dust Shroud.
18. Do not route without Cutter Head Dust Shroud in place.



LIMITED WARRANTY

MODEL 30 PAVEMENT ROUTER

Crafco, Inc. (Manufacturer), or one of its affiliated distributors, will replace for the original purchaser free of charge any parts found upon examination by the Manufacturer, to be defective in material or workmanship. This warranty is for a period **two years** from in-service date, but excludes engine or components, tires, and battery as these items are subject to warranties issued by their manufacturers.

Crafco, Inc. shall not be liable for parts that have been damaged by accident, alteration, abuse, improper lubrication/maintenance, normal wear, or other cause beyond our control.

The warranty provided herein extends only to the repair and/or replacement of those components on the equipment covered above and does not cover labor costs. The warranty does not extend to incidental or consequential damages incurred as a result of any defect covered by this warranty.

All transportation and labor costs incurred by the purchaser in submitting or repairing covered components must be borne by the purchaser. Crafco, Inc. specifically disavows any other representation, warranty, or liability related to the condition or use of the product.



WARNING:

Use of replacement parts other than genuine Crafco parts may impair the safety or reliability of your equipment and nullifies any warranty.

WARRANTY CLAIM INSTRUCTIONS

MODEL 30 PAVEMENT ROUTER

Crafco, Inc. warrants parts and machinery purchased through Crafco or one of its affiliated distributors for two years from purchased or in-service date. Wear items are not covered under the Crafco, Inc. limited warranty. A wear item is defined as but not limited to: cutters, tires, etc.

If parts fail to function within the two years of purchase, a return authorization number (RA) must be obtained. If the part was purchased through Crafco, Inc., please contact Crafco returns department at [Returns@Crafco.com](mailto>Returns@Crafco.com) for an RA number or if purchased through a Crafco distributor please contact your distributor.

Note: if the part has a serial number associated with it, for example; a machine or electric hose or wand, this must be furnished when requesting the RA number. The customer will be emailed or faxed an RA form with all instructions to return the item to Crafco, Inc. See example. If the part is found to be within the two year warranty period and has not been abused or modified, a credit will be issued to the customer's account or credit card. The customer may request the part be replaced instead of a credit, if desired.

Note: All engine warranties are covered through the engine manufacturer. If you need information for a distributor in your area please contact us and we will direct you to the closest engine distributor.

All parts returned are tested and evaluated. If the part has been modified in any way without prior consent from a Crafco, Inc. representative, warranty is void.

Please follow the instructions stated below when calling in a Warranty Claim. Failure to follow these procedures may be cause to void the warranty.

Call your local Crafco Distributor. If you do not know who your local distributor is, call a Crafco Customer Service Representative, (Toll Free 1-800-528-8242) for name, location and telephone number.

On contacting the distributor, be prepared to identify the serial number, model number, engine number, engine manufacturer, and the date of purchase if available.

Should the cause of the malfunction be a defective part, the Distributor will advise you of the procedure to follow for a replacement.

The warranty is valid only for parts, which have been supplied or recommended by Crafco, Inc.

If you have any additional questions regarding warranty repairs and parts, please do not hesitate to call toll free 1-800-528-8242.

CONTACT US

MODEL 30 PAVEMENT ROUTER

For Warranty:

Crafco, Inc.

25527 South Arizona Avenue, Chandler, AZ 85248

Phone: (480) 655-8333 or (800) 528-8242

Fax: (480) 655-1712

For all other inquiries:

Crafco, Inc.

6165 West Detroit Street, Chandler, AZ 85226

Phone: (602) 276-0406 or (800) 528-8242

Fax: (480) 961-0513

CustomerService@crafco.com

SPECIFICATIONS

MODEL 30 PAVEMENT ROUTER

Engine.....	2 Cylinder- CH752-3110 (27 HP) (20Kw)
Weight.....	534 Lbs. (242 Kg)
Fuel.....	Unleaded Gasoline
Fuel Tank Capacity.....	6 Gallons (22.7 Liter)
Maximum Depth of Cut.....	1 - 5/8" (41.3 mm)
Depth.....	Depth gauge for precise depth control.
Safety Features.....	Braking system, safety guards, electric clutch
Depth Control.....	Electric actuator for fingertip depth control.
Cutter Design.....	6 radially located sprocket shaped cutters on 11 3/4" (298.5 mm) diameter cutter head
Cutter Style:.....	Hardened steel with carbide cutter tips
Crack Cleaning.....	Up to 1500 Linear Feet (457 Linear Meters) per hour

INTRODUCTION

MODEL 30 PAVEMENT ROUTER

The **CRAFCO Model 30 Pavement Router** was designed specifically to widen and clean joints and cracks in asphalt and concrete surfaces. **The CRAFCO Model 30 Pavement Router** is not intended to be used to clean old sealant from joints and cracks.

The **CRAFCO Model 30 Pavement Dust Control Router** is a self-contained unit; no external power source is needed to operate the dust collection system. It was designed to reduce the amount of fugitive dust particles being introduced into the air when widening and cleaning joints and cracks in asphalt surfaces. The **CRAFCO Model 30 Pavement Dust Control Router** was not intended to pick up all dirt and debris from the joint or crack after routing.

The **CRAFCO Model 30 Pavement Self-Propelled Router** is a self-contained unit; no external power source is needed to operate the drive system. It was designed to reduce worker fatigue from moving from one distressed area to another. The **CRAFCO Model 30 Pavement Self-Propelled Router** was not intended to drive forward and route cracks at the same time. The handle bar has two separate drive handles, standing at the operators position the drive handle on the left works the electric clutch and the drive handle on the right works the drive wheels.

CRAFCO, Inc. and its Distributors assume no liability for accident or injury incurred through improper use of this machine.

DO NOT operate machine without reading operator's manual and being thoroughly familiar with controls:

1. Check engine crankcase oil. Add oil if low. Refer to Engine Operators Manual.
2. Fill engine gas tank with clean, fresh, unleaded gasoline. See "Fuel Recommendations" in Engine Operators Manual.
3. Check tire inflation. Proper tire inflation is 45 psi. Machine will be difficult to roll with under-inflated tires.
4. Check engine cooling air intake and external surfaces of engine. Clean if dirty or obstructed.
5. Check that the air cleaner components and all shrouds, equipment covers, and guards are in place and securely fastened.

ENGINE OPERATING INSTRUCTIONS

MODEL 30 PAVEMENT ROUTER

Cold Weather Starting Hints

1. Be sure to use the proper engine oil for the temperature expected. See Kohler Owners Manual for recommended SAE Viscosity Grades.
2. Set speed control at part throttle position.
3. A warm battery has much more starting capacity than a cold battery.
4. Use fresh winter grade fuel.

NOTE: Winter grade gasoline has a higher volatility to improve starting. Do not use gasoline leftover from summer.

Starting

1. To start engine, place the throttle control midway in the “**slow**” position, and place the choke control into the “**on**” position.

NOTE: With non-electric clutch you must pull and hold the engine stop switch at the operator’s position for the engine to start and run.

2. Start the engine by activating the key switch. Release the switch as soon as the engine starts.

NOTE: Do not crank the engine continuously for more than 10 seconds at a time. If the engine does not start, allow a 60 second cool down period between starting attempts. Failure to follow these guidelines can burn out the starter motor.

NOTE: Upon start-up a metallic ticking may occur. This is caused by the hydraulic lifter leakdown during storage. Run the engine for 5 minutes. The noise will normally cease in the first minute. If noise continues, run the engine at mid throttle for 20 minutes. If noise persists, take the engine to your local Kohler Service Engine Dealer.

NOTE: If the engine develops sufficient speed to disengage the starter, but does not keep running (a false start), the engine rotation must be allowed to come to a complete stop before attempting to restart the engine. If the starter is engaged while the flywheel is rotating, the starter pinion and flywheel ring gear may clash, resulting in damage to the starter.

If the starter does not turn the engine over, shut off starter immediately. Do not make further attempts to start the engine until the condition is corrected. Do not start using another battery. See your Kohler Engine Service Dealer for trouble analysis.

ENGINE OPERATING INSTRUCTIONS (Continued)

MODEL 30 PAVEMENT ROUTER

3. **For a Cold Engine:** Gradually return the choke control to the “**off**” position after the engine starts and warms up. The engine/equipment may be operated during the warm-up period, but it may be necessary to leave the choke partially on until the engine warms up.
4. **For a Warm Engine:** Return the choke to “off” position as soon as engine starts.

Stopping

Place the throttle control midway between the “**slow**” and “**fast**” positions. Allow the engine to run a minimum of 15 seconds; then stop the engine.

Battery

A 12 volt battery is used. If the battery charge is not sufficient to crank the engine, recharge the battery.

OPERATING

Angle of Operation

The engine will operate continuously at angles up to 25 degrees. Check oil level to assure crankcase oil level is at the “**F**” mark on the dipstick. Do not operate the engine continuously at angles exceeding 25 degrees in any direction. Engine damage could result from insufficient lubrication.

Cooling

NOTE: If debris builds up on the screen or other cooling air intake areas, stop the engine immediately and clean. Operating the engine with blocked or dirty air intake and cooling areas can cause extensive damage due to overheating.

WARNING: Hot Parts!

Engine components can get extremely hot from operation. To prevent severe burns, do not touch these areas when the engine is running or immediately after it is turned off. Never operate the engine with heat shields or guards removed.

Engine Speed

NOTE: Do not tamper with the governor setting or increase the maximum engine speed. Overspeed is hazardous and will void the engine warranty. The high idle speed for this engine is 3750 RPM, no load.

OPERATING PROCEDURES

MODEL 30 PAVEMENT ROUTER



WARNING: Lethal Exhaust Gases!

Engine exhaust gases contain poisonous carbon monoxide. Carbon monoxide is odorless, colorless, and can cause death if inhaled. Avoid inhaling exhaust fumes, and never run the engine in a closed building or confined area.

NOTE: STEPS 1 THROUGH 6 APPLY ONLY TO THE DUST CONTROL ROUTER. OTHERWISE MOVE DOWN TO ITEM NUMBER 7.

ATTACHING CUTTER HEAD DUST SHROUD

1. To make attaching the cutter head dust shroud more accessible, raise the front of the router. To raise the front of the router, push down on the handle bars until the router is resting on the handle and the corner of the frame assembly. (Figure 1)



Figure 1

2. Remove cutter head dust shroud from the storage bracket and bring around to front of router. Bring the shroud up from the bottom of the housing and align the pin hole with the slots in the mounting brackets. Install the pin and secure with washer and 5/16" x 3/8" hairpin.

OPERATING PROCEDURE (Continued) MODEL 30 PAVEMENT ROUTER

NOTE: ATTACHING CUTTER HEAD DUST SHROUD CONTINUED

3. Use the Brush Manipulation Tool to push the Seal Brushes on both sides of shroud up above the cutter housing. The brushes should be in an upward position. (Figure 2)

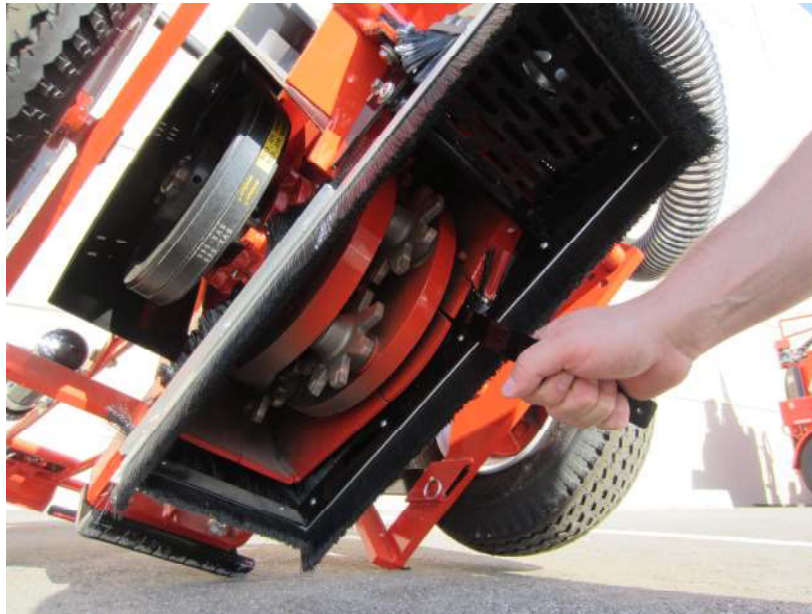

Figure 2

4. Lower the router back onto its wheels.
5. Make sure the large particle dust collection bin is empty and is securely attached to mounting bracket before beginning your routing operation.
6. Make sure the dust collection bag is clean and securely clamped to filter mounting bracket with adjustable quick release gear clamp. The quick release gear clamp is adjustable and should be adjusted so that it holds the dust collection bag securely in place. Do not over-tighten the clamp as this may damage the dust collection bag. The support rod was designed so it could be slid into a rearward position for transportation of router where space is limited. The support rod should be fully extended in its forward position before routing begins.
7. Raise the cutter mechanism by pushing the rocker switch to the up position.
8. Open fuel valve on bottom of fuel tank.

NOTE: ATTACHING CUTTER HEAD DUST SHROUD COMPLETED

OPERATING PROCEDURE (Continued)

MODEL 30 PAVEMENT ROUTER

9. Start engine. Refer to page 12-13 for complete engine starting instructions.

NOTE: It is recommended that you read the Kohler Owners Manual before starting the engine.

10. Black smoke from the exhaust and a rough running engine usually indicate over-choking.

TO CLEAN JOINTS AND CRACKS

11. Open throttle for maximum engine speed. Position machine over joint and line up pointer with joint. Engage electric clutch by pulling up on “Clutch” handle. Machine is operated by manually guiding the machine while walking backwards. The stabilizer mechanism is designed to stabilize the machine and to act as a brake. Always engage electric clutch before lowering cutter head into the joint.



WARNING:

The Model 30 pavement router pushes toward operator when routing. Tightly compacted surfaces, deep or wide cuts, or hard aggregate may cause sudden machine movement toward operator. This “kickback” could cause operator to lose his balance or control of machine resulting in serious personal injury. When operating, keep wear plate in contact with pavement and hold handle with both hands. For Emergency Stop, push down firmly on machine handle or release safety “Clutch” handle, which disengages the electric clutch. Push machine handle away.

12. Engage electric clutch by pulling up on “Clutch” handle. Lower cutter head until cutters slightly touch the surface. Notice shade and number on the depth indicator (Figure 3). Each shade represents approximately 1/4 inch (6.35 mm) depth variation.



Figure 3

OPERATING PROCEDURE (Continued)

MODEL 30 PAVEMENT ROUTER

13. **Do not try to go too fast. Do not overload the engine.** Overloading the engine will slow cutting action and cause damage to engine and drive components. A bouncing or hammering action usually indicates the machine is moving too fast or the cutters have worn out of round (refer to Troubleshooting Section, page 35). Let the machine thoroughly clean the joint. For deep cuts (deeper than 3/4 inch (19 mm)) it may be necessary to make two passes. A stabilizer mechanism (Figure 4) is used on the Crafcro Pavement Router to improve the stability of the machine and to act as a brake.

TO SLOW OR STOP THE ROUTER, SIMPLY PUSH DOWN ON THE HANDLE OR RELEASE SAFETY “CLUTCH” HANDLE WHICH DISENGAGES THE ELECTRIC CLUTCH.

For normal operation, let skid plate drag on paved surface while machine is in operation.

Skid plate (Part No. 20919) should be replaced before wear reaches the vertical leg of the bent angle.



Figure 4

OPERATING PROCEDURE (Continued) MODEL 30 PAVEMENT ROUTER

NOTE: STEPS 14 THROUGH 17 APPLY ONLY TO THE DUST CONTROL ROUTER. OTHERWISE MOVE DOWN TO ITEM NUMBER 18.



WARNING:

Never operate the unit without all the dust control components attached, in particular the cutter head dust shroud. This could cause injury or damage from flying debris.

14. As you begin to route, the dust that is sucked up from the cutterhead shroud enters the cyclone where a majority of the debris is spun out of the air stream and deposited in the large particle dust collection bin. The amount of time or distance that can be routed before the large particle dust collection bin will need to be emptied will vary depending on the condition of the asphalt, approximately 500 to 1000 feet (150 to 300 meters) When beginning a routing operation, check the large particle dust collection bin frequently to gauge the distance that can be routed before emptying the large particle dust collection bin. The large particle dust collection bin should be emptied at approximately 3/4 to 7/8 full. (Figure 5) Beyond this point, the debris will be sucked up through the cyclone and deposited in the dust collection bag, reducing the run time of the dust collection bag.

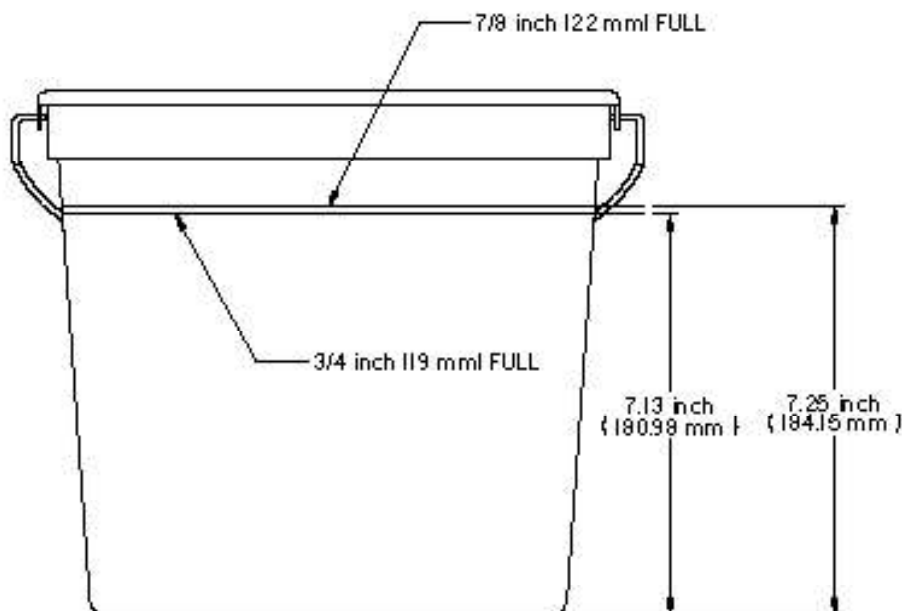

Figure 5

OPERATING PROCEDURE (Continued)

MODEL 30 PAVEMENT ROUTER

NOTE: DUST CONTROL ROUTER OPERATING PROCEDURES CONTINUED

15. To empty the large particle dust collection bin, reduce engine speed to idle. Support the bottom of the large particle dust collection bin with one hand, keeping the large particle dust collection bin pressed up firmly against the mounting bracket. With your other hand, unlatch the rubber latches on the large particle dust collection bin.



CAUTION:

(The large particle dust collection bin weighs approximately 30 lbs when full)

Dump the large particle dust collection bin in a larger receptacle where it can be disposed of properly at a later time. Reattach the large particle dust collection bin to the mounting bracket. Return engine to high speed and continue routing.

16. While the engine is at idle during the previous step, gently shake or lightly tap sides of the dust collection bag with your hand.

NOTE: During router operation, what dust isn't spun out by the cyclone, enters the dust collection bag. This dust forms a "Dust Cake" on the inside wall of the dust collection bag and will restrict the amount of air that can escape through the dust collection bag, reducing the overall suction of the system. Tapping on the side of the dust collection bag will knock this dust cake loose from the sides of the dust collection bag, increasing the amount of time that can be routed before the dust collection bag will need to be serviced. (see page 58)

17. At the end of the day remove the cutter head dust shroud and store on the Shroud Storage Bracket located on top of the cyclone. **Do Not** leave the router resting on the seal brushes as they will deform. Excessive deformation of the seal brushes will hinder the shrouds ability to trap dust behind the shroud, reducing the efficiency of the dust collector.

NOTE: DUST CONTROL ROUTER OPERATING PROCEDURES COMPLETED

18. As cutters wear, depth of cut will change. To compensate for cutter wear, repeat step #2 as often as necessary to reset depth.
19. When cutters will no longer cut to desired depth, they must be replaced. Refer to cutter changing section on Page 26.
20. Governor speed is set for the most efficient cutting action. Increasing engine speed may hinder cutter action and also void warranty.

OPERATING PROCEDURE (Continued) MODEL 30 PAVEMENT ROUTER

NOTE: STEP 19 APPLIES ONLY TO THE SELF-PROPELLED ROUTER

21. Reduce engine to idle, stand at the operators position, raise the handle slightly so the router is not resting on the skid plate. Pull up on the right hand drive handle to engage the self-propelled drive system and walk behind the router towards the next distressed area and release the drive handle when your ready to stop moving.

STORING THE MACHINE MODEL 30 PAVEMENT ROUTER

CRAFCO Model 30 Pavement Router and Self-Propelled Router.

DO NOT rest the weight of the machine on the rubber rock deflector or rubber will become deformed, causing them not to function properly. Store with engine in a near level position.

Dust Control Router

DO NOT leave the machine resting on the seal brushes or the brushes will become deformed, causing them not to function properly. The dust collection bag should be stored in a covered area out of direct sunlight and away from moisture. Store the dust collection bag in a place where it won't be inadvertently torn or damaged.

MAINTENANCE

MODEL 30 PAVEMENT ROUTER

Oil Recommendations

Using the proper type and weight of oil in the crankcase is extremely important. So is checking oil daily and changing oil regularly. Failure to use the correct oil, or using dirty oil, causes premature engine wear and failure.

Oil Type

Use high quality detergent oil of API (American Petroleum Institute) service class SG or SH. Select the viscosity based on the air temperature at the time of operation as shown in the following table.

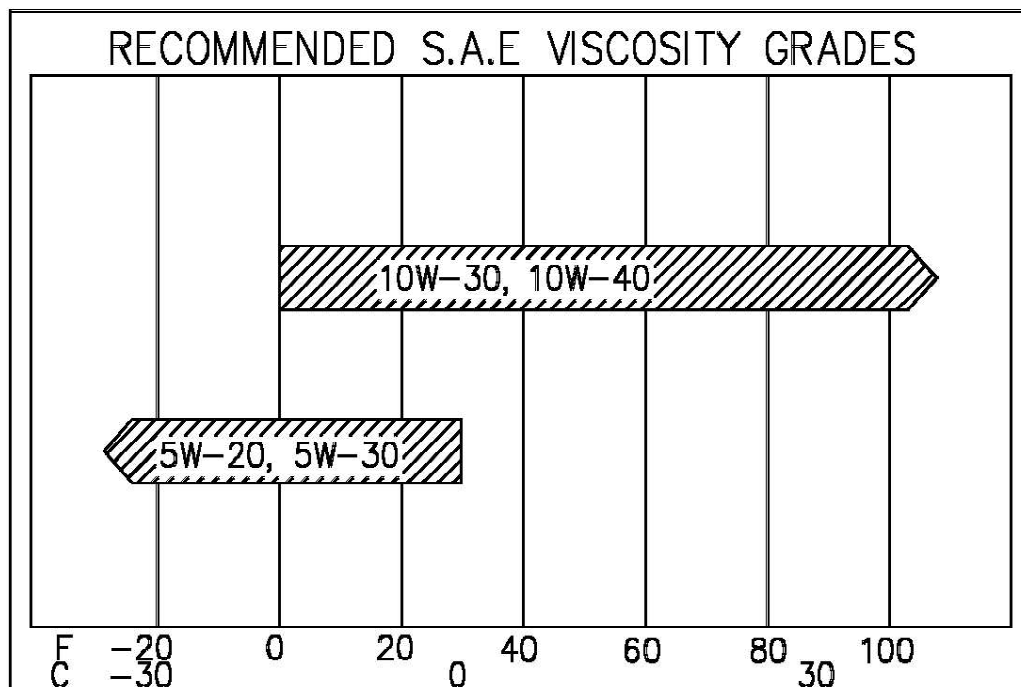

NOTE: Using oil other than service class SG or SH or extending oil change intervals longer than recommended can cause engine damage. Refer to the Maintenance instructions on page 22 or the [Kohler Owners Manual](#) for detailed oil check, oil change, and oil filter change procedures and intervals.

Fuel Recommendations

WARNING: Explosive Fuel!

Gasoline is extremely flammable and its vapors can explode if ignited. Store gasoline only in approved containers, in well ventilated, unoccupied buildings away from sparks or flames. Do not fill the fuel tank while the engine is hot or running, since spilled fuel could ignite if it comes in contact with hot parts or sparks from ignition. Do not start the engine near spilled fuel. Never use gasoline as a cleaning agent.

MAINTENANCE (Continued)

MODEL 30 PAVEMENT ROUTER

General Recommendations

Purchase gasoline in small quantities and store in clean, approved containers. A container with a capacity of 2 gallons or less with a pouring spout is recommended. Such a container is easier to handle and helps eliminate spillage during refueling.

To minimize gum deposits in your fuel system and to insure easy starting, do not use gasoline left over from the previous season.

Do not add oil to the gasoline.

Do not over-fill the fuel tank. Leave room for the fuel to expand.

Fuel Type

For best results use only clean, fresh, unleaded gasoline with a pump sticker octane rating of 87 or higher. In countries using the Research method, it should be 90 octane minimum.

Unleaded gasoline is recommended as it leaves less combustion chamber deposits. Leaded gasoline may be used in areas where unleaded is not available and exhaust emissions are not regulated. Be aware, however, that the cylinder heads may require more frequent service.

Gasoline/Alcohol Blends

Gasoline (up to 10% ethyl alcohol, 90% unleaded gasoline by volume) is approved as a fuel for Kohler engines. Other gasoline/alcohol blends are not approved.

Gasoline/Ether Blends

Methyl Tertiary Butyl Ether (MTBE) and unleaded gasoline blends (up to maximum of 15% MTBE by volume) are approved as a fuel for Kohler engines. Other gasoline/ether blends are not approved.

Battery

Check charge condition. Keep battery connections tight and clean.

Battery Recharging

When recharging, do not use a battery charger rated for more than 8 AMP's. If the battery has fallen below 10.5 volts, a charger made specifically for charging AMG batteries is required. Do not overcharge the battery.

MAINTENANCE (Continued)

MODEL 30 PAVEMENT ROUTER

WARNING: Explosive Gas!

Batteries produce explosive hydrogen gas while being charged. To prevent a fire or explosion, charge batteries only in well ventilated areas. Keep sparks, open flames, and other sources of ignition away from the battery at all times. Keep batteries out of the reach of children. Remove all jewelry when servicing battery.

PERIODIC MAINTENANCE

MODEL 30 PAVEMENT ROUTER

Follow a regular schedule of inspection and servicing, based on operating hours. Keep an accurate logbook of maintenance, servicing, and operating time. Use the factory recommended Periodic Maintenance Schedule (based on favorable operating conditions) to serve as a guide to get long and efficient engine life.

For severe duty, extreme temperature, etc., service more frequently. Neglecting routine maintenance can result in engine failure or permanent damage.

For any abnormalities in operation, unusual noises from the engine or accessories, loss of power, overheating, etc., contact your nearest Kohler Service Center.



WARNING:

Inhalation of exhaust gases can result in serious personal injury or death. **DO NOT** use the air cleaner or exhaust elbow as a supporting step. Damage of these and connecting parts might cause an exhaust leak.



WARNING: Accidental Starts!

Before servicing the engine or equipment on the machine, always disconnect the spark plug leads to prevent the engine from starting accidentally. Ground the leads to prevent sparks that could cause fires.

MAINTENANCE SCHEDULE

MODEL 30 PAVEMENT ROUTER

These required maintenance procedures should be performed at the frequency stated in the chart below. They should also be included as part of any seasonal tune-up.

FREQUENCY	MAINTENANCE REQUIRED
Daily or before starting engine	Fill fuel tank. Check oil level. *Check air cleaner for dirty, loose or damaged parts. *Check air intake and cooling areas, clean as necessary. Grease cutter shaft bearings. Blow loose dust/dirt off engine.
Every 25 hours	*Service air cleaner dust cap. *Service primary air cleaner element.
Every 100 hours	Change Oil. *Remove cooling shrouds, and clean as necessary. Check oil cooler fins. Check spark plug condition and gap if necessary.
Every 200 hours	Change Oil Filter. *Check secondary air cleaner element and foam wrap.
Annually or every 500 hours	**Have starter drive serviced. **Have solenoid shift starter disassembled and cleaned. Repack wheel bearings.

*Perform these maintenance procedures more frequently under extremely dusty, dirty conditions.

**Have a Kohler Engine Service Dealer perform this service.

SERVICE AND MAINTENANCE INSTRUCTIONS

MODEL 30 PAVEMENT ROUTER

For longer engine life, the Model 30 Pavement Router has been fitted with a High Capacity Air Cleaner (primary) and secondary element. Due to the dusty conditions created during operation, it is necessary to service the air cleaner when it becomes clogged with dirt.

To change the primary air cleaner element, loosen the clamp and remove the air cleaner cap.

1. Service element only when restriction indicator reaches the service level (indicator pops up). It is only above that point that air cleaner restriction begins to reduce engine performance level. When restriction finally indicates a change, remove the primary element carefully. When element replacement is needed use Crafcro 31344.
2. Do not attempt to clean the dirty element. Rapping, or pounding dirt out is dangerous and could cause damage to the element.
3. Carefully check new element for damage before installing.
4. Reinstall new element, replace air cleaner cap and fasten retaining clips.

Check the secondary element (safety) only if the primary air cleaner element was damaged.

1. Remove the air cleaner cover.
2. Remove the primary element.
3. Remove the safety element.
4. Handle new elements carefully: do not use if the sealing surfaces are bent or damaged.
5. Reinstall the new safety element, primary element and air cleaner cap. Fasten retaining clips.
6. When element replacement is necessary, order Crafcro P/N 31345.

Check engine oil daily. Change oil after every 100 hours of operation. Change oil filter every 200 hours. Use Crafcro P/N 31330. (Refer to engine owners manual).

Check fluid level in battery regularly.

Every 50 hours of operation clean out cooling fins on engine. If dust is allowed to accumulate overheating may occur, causing damage to the engine.

Lubricate cutter shaft bearings every 100 hours using multi-purpose grease.

Lubricate frame pivot every 50 hours using multi-purpose grease.

Tighten all bolts on machine frequently.

SERVICE AND MAINTENANCE INSTRUCTIONS (CONT'D) MODEL 30 PAVEMENT ROUTER

After 2 hours of operation check and tighten the V-belts as required. To tighten belts, adjust jam nuts under engine mount. (Figure 6)



Figure 6



CAUTION:

Do not over-tighten belts as damage will occur to belts and bearings. Belts that are too loose will shorten the life of the belts and sheaves. Recheck belt tension after 8 hours and every 40 hours thereafter. When installing new belts do not attempt to stretch over sheaves. Always replace both belts and inspect sheaves for wear.

Clean machine each day using compressed air or by wiping with rags, especially in area of engine cooling fins.

Periodically inspect the in-line fuel filter and replace when dirty. Use Crafcro P/N 31331.

Always use genuine Crafcro cutters and other replacement parts. Failure to do so will void warranty and possibly cause damage to machine or injury to operator.

CHANGING CUTTERS MODEL 30 PAVEMENT ROUTER

The procedure outlined below will greatly simplify cutter changing.



WARNING:

ENGINE MUST NOT BE RUNNING WHEN CHANGING CUTTERS OR WORKING ON ANY PART OF MACHINE. SERIOUS INJURY OR DEATH COULD RESULT. DO NOT ALLOW ANYONE TO PULL ON HANDLE, START ENGINE, OR DO ANY OTHER MAINTENANCE WHILE WORKING ON CUTTER HEAD.

NOTE: With the Dust Control Router the cutter housing shroud must be in the stored position before moving to the next step.

1. Raise cutter mechanism to maximum height. Push machine forward while holding handle up. This will allow rock deflector to fold up and machine to tilt forward exposing cutters for easy accessibility. Make sure front stand is supporting machine before releasing handle. (Figure 7)



Figure 7

CHANGING CUTTERS (Continued) MODEL 30 PAVEMENT ROUTER

2. Remove click pin on rear stand, lower support strip, and reinstall click pin to lock strip in place. (Figure 8)



Figure 8

3. Place wrench supplied with machine on exposed bolt in cutter window. (Figure 9). Turn clockwise to rotate cutter head to end of cutter window. This will rotate cutter head for proper indexing. Do not attempt to turn cutter head with hands.



Figure 9

CHANGING CUTTERS (Continued) MODEL 30 PAVEMENT ROUTER

4. Remove wrench and place on bolt just exposed. Loosen bolt at least one full turn. Slide retainer back exposing pin.
5. Using pin removal tool (also supplied with machine) push pin all the way out, except when changing pins. (Figure 10) Remove worn cutters and/or worn pins. Pins should be replaced when worn in any area to a diameter less than 3/4 inch. Use pin as a pilot to mount spacers and cutters. Make sure carbide tips are positioned per Cutter Installation Warning page 39.



Figure 10

6. Slide retainer back into position and tighten bolt.



CAUTION:

It is most important that retainer is always put back in the locked position. As the bolt is tightened, the cutter head will rotate clockwise exposing next cutter.

7. Repeat steps 3, 4 and 5 for other five cutter positions.
8. Remove click pin from rear stand, move support strip to upper position and reinstall click pin.
9. Lower machine to operating position. See page 40-41 for cutter configurations. Call Crafcro or your local Crafcro Distributor for any additional questions you may have.

CHANGING CUTTER HEADS MODEL 30 PAVEMENT ROUTER

It is recommended that the cutter head be changed when holes for pins are worn to 1.000 in diameter or larger.

REMOVING OLD CUTTER HEAD AND MAIN SHAFT

1. Remove belt guard. (Figure 11)



Figure 11

CHANGING CUTTER HEADS MODEL 30 PAVEMENT ROUTER

2. Back off belt tension, adjusting bolt jam nuts all the way and remove the V-belts. (Figure 12).



Figure 12

3. Tip the router back, lowering handle all the way to the ground.
4. Remove wheels.
5. Remove lower sheave. The sheave has a built in puller. Loosen and remove the three mounting cap screws. Insert these same cap screws in the threaded jack-screw holes. Starting with the screw farthest from the bushing saw slot; tighten all screws alternately and progressively to separate sheave from bushing.
6. Drive a wedge into the slot of bushing, barely enough to free the bushing and slide bushing off shaft.
7. Lift handle to set machine flat on ground, then remove top three cap screws in each of the two main shaft bearings. It is not necessary to remove bottom cap screw in each bearing but leave it intact.
8. Push handle down all the way to the ground again, this will lift the front of the router, freeing the cutter head assembly from the cutter housing. Then roll the cutter head from under the router.

INSTALLING NEW CUTTER HEAD AND MAIN SHAFT MODEL 30 PAVEMENT ROUTER

The cutter head and main shaft are sold in matched sets and must be installed together.

1. Slip the bearings on to the main shaft in the new cutter head.
2. Push the handle down all the way to the ground to raise the front of machine.
3. Roll new cutter head assembly under machine and into position.
4. Line up bearings with cutout sections in the flywheel housing, fitting each into its slot as machine is lowered over flywheel.
5. Reinstall three cap screws that attach bearings to flywheel housing.
6. Center cutter head in housing and move main shaft so that it is flush with bearing on side opposite sheaves.
7. Replace locking ring mechanism on each bearing (if equipped).
8. If bearings do not use a locking ring, follow this procedure: Using 1/4" electric drill and 13/64" drill bit, make dimple in shaft under one or more set screws. Remove two set screws on each bearing and coat with a thread adhesive such as Loctite. Replace set screws and tighten until snug.
9. Reinstall hub and lower sheave. Be sure the sheaves are in alignment using straight edge.
10. Tighten cap screws that pull the sheave onto bushing alternately and progressively until tapers are seated. Check alignment and sheave run out or wobble and correct as necessary before tightening cap screws to recommended torque value of 15 ft. - lbs. each.
11. Reinstall wheel and tire assemblies.
12. Install V-belts and tighten tension using the jam nuts underneath motor mount. Correct belt tension is 1/4" deflection per belt when 10 lbs. pressure is applied.
13. Install belt guard.
14. Install cutters, shafts and spacers as outlined in changing cutters, page 27.

CHANGING V-BELTS MODEL 30 PAVEMENT ROUTER

1. Remove belt guard by removing 4 bolts. (Figure 13).



Figure 13

2. Loosen belt tensioner until bottomed out. (Figure 14).



Figure 14

CHANGING V-BELTS (Continued) MODEL 30 PAVEMENT ROUTER

3. Remove old belts. Install new belts.
4. Tighten belt tensioner. Correct tension is 1/4" deflection per belt when 10 lbs. pressure is applied. Incorrect belt tension will cause poor belt life, damage to bearings, and engine crankshaft bearing failure.
5. Install belt guard.

ELECTRIC CLUTCH MODEL 30 PAVEMENT ROUTER

The Model 30 is equipped with an electric clutch which can be engaged independently of engine operation. Under normal operation, no service of this clutch is required. If the V-grooves should become worn, a completely new clutch assembly (31289) must be installed.

(Figure 15)



Figure 15

TROUBLE-SHOOTING GUIDE

MODEL 30 PAVEMENT ROUTER

PROBLEM	CAUSE	REMEDY
Cutters wear out of round.	Cutters not spinning on pins thereby creating uneven wear.	Don't cut so deep. Take two passes to get to the required depth. Check to see if washer count is correct. Refer to pages 40-41.
Engine stalls.	No spark.	Check electric system for defective wires, switches, etc.
	Inadequate supply of fuel to carburetor.	Check fuel pump, fuel valve and lines.
Machine fails to raise or lower.	Damaged switch, wiring, or fuse.	Replace defective components.
	Defective worn linear actuator.	Replace linear actuator.
Engine doesn't spin properly when cranking.	Starter problems.	Repair or replace starter.
	Low battery.	Charge or replace battery.
Engine missing, loss of power.	Dirty carburetor.	Clean carburetor.
	Defective fuel pump.	Replace fuel pump.
Engage drive system by pulling up on the handle and nothing happens.	Pulling the wrong handle.	The drive system is controlled by the right hand handle.
	Drive cable has too much slack.	Adjust the cable so that the drive system starts to move as you begin to pull the handle.
	Both tires are not at the correct tire pressure	Make sure both tires are at the recommended P.S.I. rating.
The Dust Control System is not controlling the dust as well as it once did.	Hoses and guards are not properly positioned.	Review the operating procedures and make sure everything is properly placed.
	Either the dust collection bag or the large particle dust collection bin need to be cleaned.	Clean the dust collection bag and/or dump out the large particle dust collection bin
	Old brushes on the cutter head dust shroud.	Replace all the brushes on the cutter head dust shroud.

CUTTER HEAD & DRIVE COMPONENTS MODEL 30 PAVEMENT ROUTER

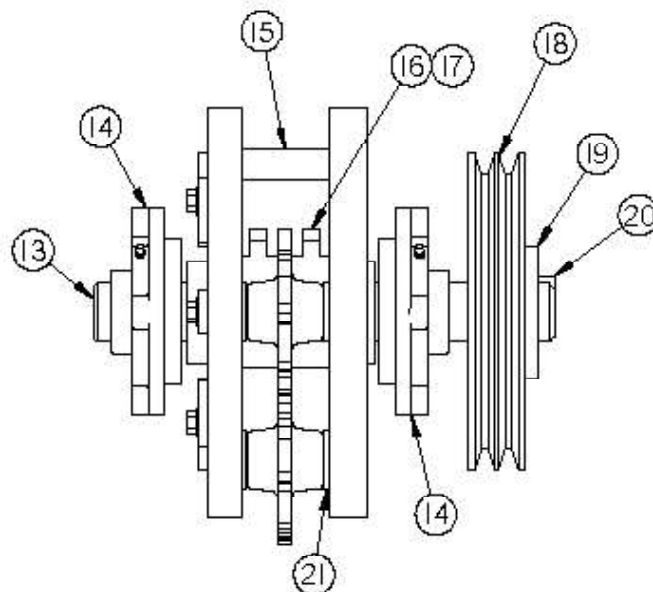
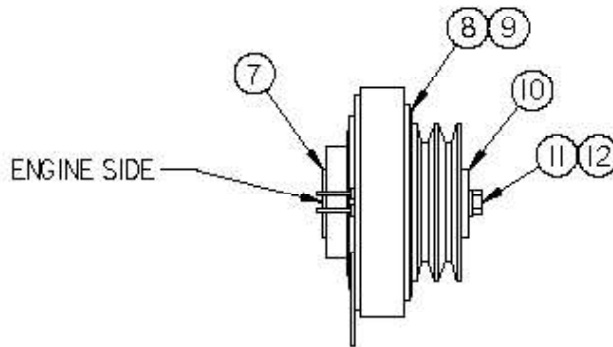
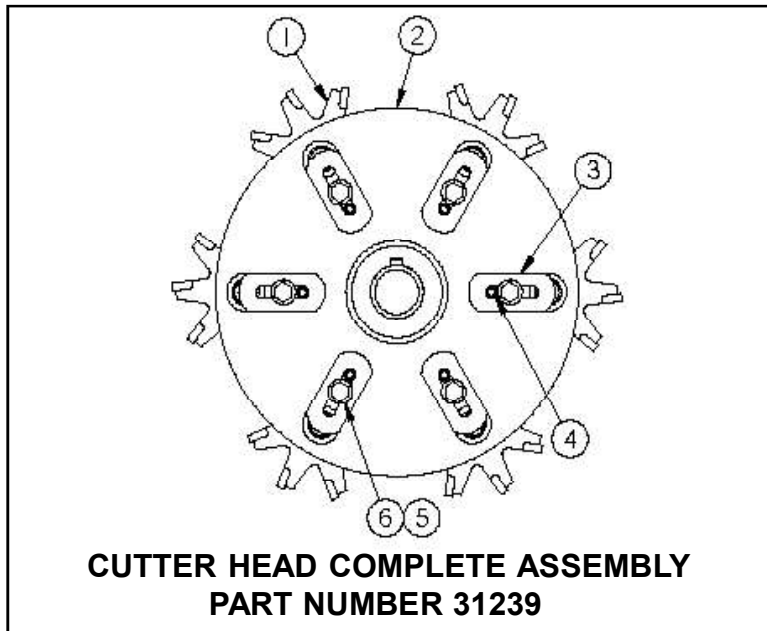





**CUTTER HEAD & DRIVE COMPONENTS
SEE PARTS LIST ON PAGE 37**

CUTTER HEAD & DRIVE COMPONENTS PARTS LIST MODEL 30 PAVEMENT ROUTER

NUMBER	PART NUMBER	QTY	DESCRIPTION
1	31145	6	WIDE HUB CARBIDE TIPPED CUTTER
2	31032	1	CUTTER HEAD
3	31120	6	RETAINING TAB
4	32061	6	3/8 X 3/4 ROLL PIN
5	28672	6	3/8" FLAT WASHER
6	32039	6	3/8"-16 X 3/4" BOLT
7	28688	1	INNER WASHER (NEXT TO ENGINE)
8	31289	1	ELECTRIC CLUTCH
9	31004	1	KEY, 1/4 X 2 3/4
10	28689	1	RETAINING WASHER (NEXT TO CLUTCH)
11	28897	1	BOLT, 7/16 X 1 1/4
12	28684	1	WASHER
13	31073	1	MAIN SHAFT
14	32043	2	BEARING
15	31114	6	CUTTER PIN
16	28847	2	1/2 SQ HED SET SCREW
17	31072	1	KEY- 3/8 X 4
18	32072	1	SHEAVE
19	32071	1	1 3/4 BUSHING
20	31071	1	3/8 SQ KEY X 1 5/8 LONG
21	32093	X	7/8 HARDENED F436 SPACER

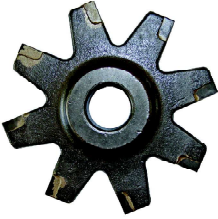
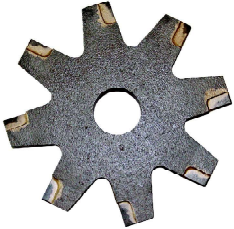
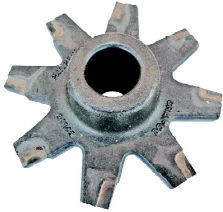
PAVEMENT CUTTER SELECTION MODEL 30 PAVEMENT ROUTER

<p>31134 Standard Steel Standard Hub</p>		<p>PCC Pavement AC Pavement</p>	<p>Cast steel cutter for use with 11 hardened steel spacers. Able to be configured to cut 1/2" wide to 1 1/2" wide. (See page 40 Figure 16)</p>
<p>31136-7 Carbide Tip Standard Hub</p>		<p>AC Pavement</p>	<p>Cast Steel Cutter with a Carbide insert cutting surface. For use with 11 hardened steel spacers. Able to configure to cut 1/2" to 1 1/2" wide. (See page 40 Figure 16)</p>
<p>31149 Carbide Tip Standard Hub Extended Life</p>		<p>AC Pavement</p>	<p>Hardened Cast Steel Cutter with a Carbide insert cutting surface for extended cutting life. For use with 11 hardened steel spacers. Able to configure to cut 1/2 to 1 1/2" wide. (See page 40 Figure 16)</p>
<p>31135 Carbide Tip Wide Cut</p>		<p>AC Pavement</p>	<p>Cast Steel Cutter with a Carbide insert cutting surface. Hub removed to allow the cutter to be stacked for wider cuts. For use with up to 15 hardened steel spacers. Able to be configured to cut 1/2 to 2" wide. (See page 40 Figure 17)</p>
<p>31145 Carbide Tip Wide Hub (patent pending)</p>		<p>AC Pavement</p>	<p>Cast Steel Cutter with a Carbide insert cutting surface. For use with 2 hardened steel spacers (cutters come with 2 spacers). Able to be configured to cut 1/2" to 3/4" wide. Designed to provide a cleaner cut. (See page 41 Figure 18)</p>
<p>31138 Carbide Tip Extra Long</p>		<p>AC Pavement</p>	<p>Cast Steel Cutter with a Carbide insert cutting surface. with longer teeth for cutting depth up to 2". For use with 12 hardened steel spacers. Able to be configured to cut 1/2 to 1 1/2" wide. (See page 41 Figure 19)</p>

CUTTER INSTALLATION WARNING

MODEL 30 PAVEMENT ROUTER



WARNING:

Install replacement cutters as shown. Failure to install correctly will result in rapid deterioration of carbide tip.

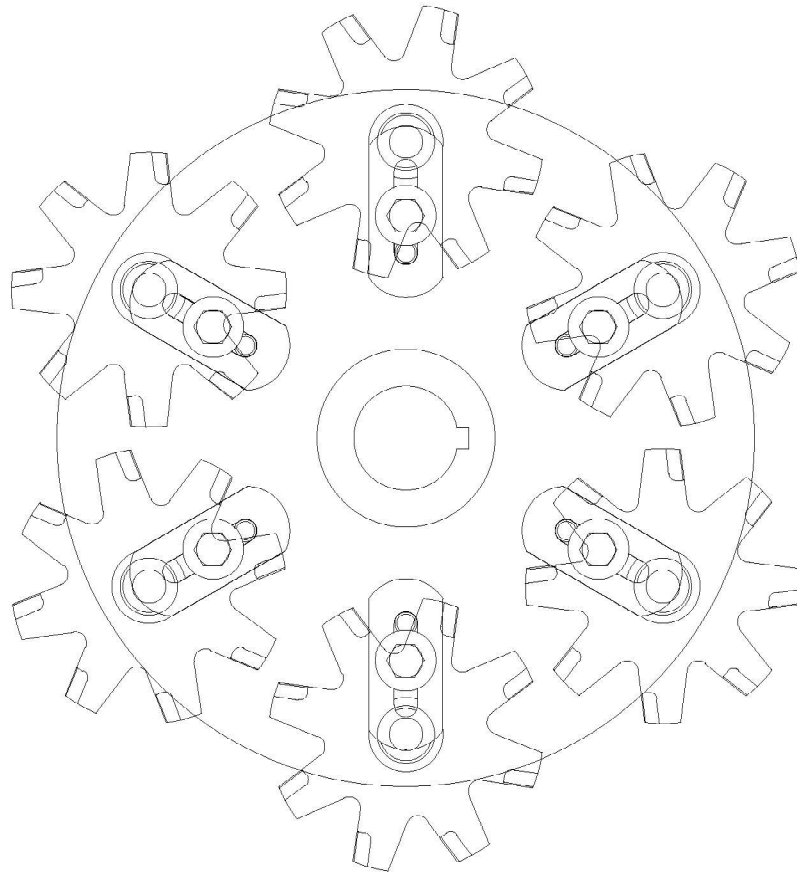

FRONT OF ROUTER

REAR OF ROUTER

CUTTER POSITIONING MODEL 30 PAVEMENT ROUTER

Figure 16
Cutter Positioning for Part Number
31134, 31136-7, 31149

Cutters can be aligned or staggered to configure the desired cut width. For wider cutting additional cutters can be added to a single pin to achieve a smoother finished cut. Always use enough Hardened Spacers to keep cutters appropriately positioned on the pin while still allowing the cutter to turn completely free..

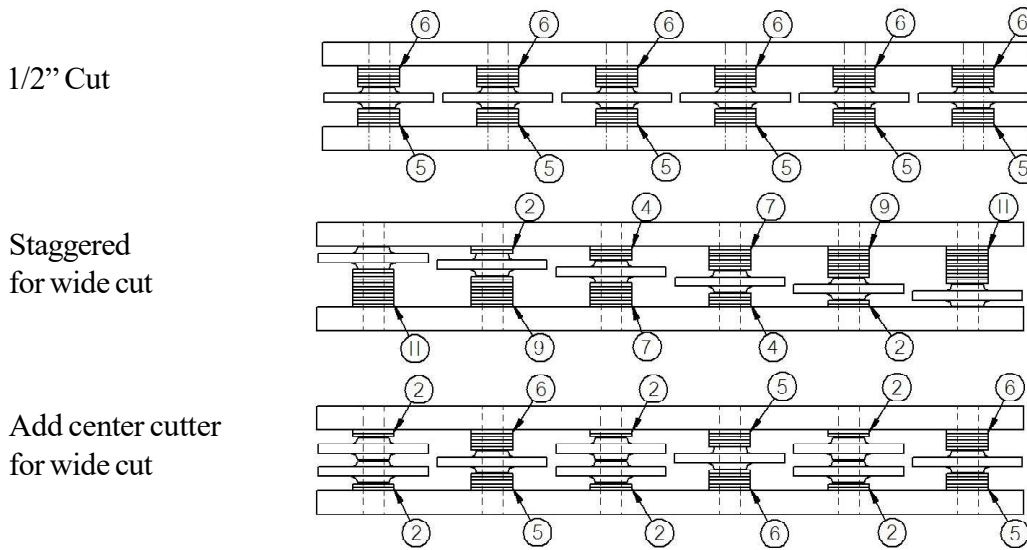
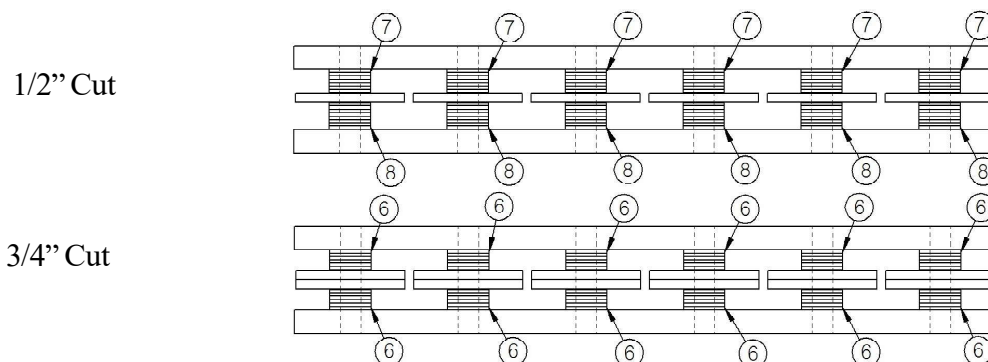

Figure 17
Cutter Positioning for Part Number
31135 Shaved Cutter

Cutters can be aligned to configure the desired cut width. For wider cutting additional cutters can be added to a single pin to achieve a smoother finished cut. Always use enough Hardened Spacers to keep cutters appropriately positioned on the pin while still allowing the cutter to turn completely free. The main consideration is placing equal number of cutters and spacers on opposite pins to maintain balance. Failure to do so could result in permanent damage to the machine and possible injury to the operator.



CUTTER POSITIONING MODEL 30 PAVEMENT ROUTER

Figure 18

Cutter Positioning for Part Number
31145(patent pending)

Cutters can be aligned or staggered to configure the desired cut width. Two Hardened Spacers are used with this cutter. Cutter produces a cleaner cut and less cutter bore wear.

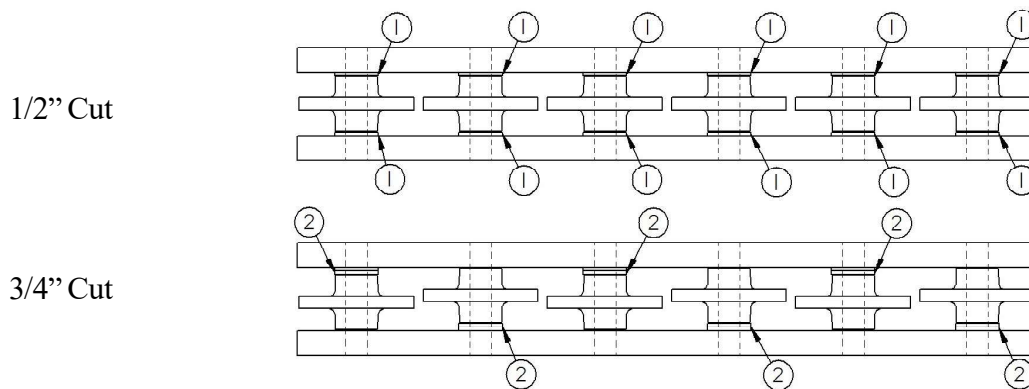
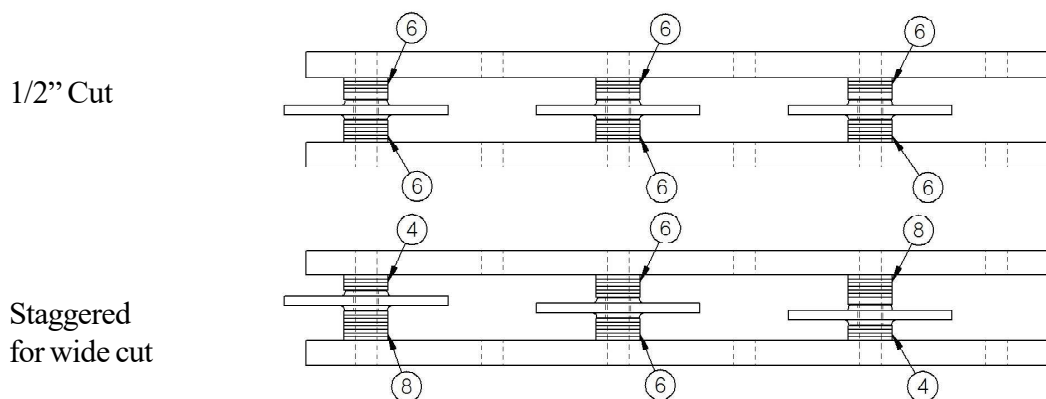

Figure 19

Cutter Positioning for Part Number
31138- 6 1/2" Cutter

Cutters can be aligned or staggered to configure the desired cut width. For wider cutting additional cutters can be added to a single pin to achieve a smoother finished cut. Always use enough Hardened Spacers to keep cutters appropriately positioned on the pin while still allowing the cutter to turn completely free.



PARTS LIST

MODEL 30 PAVEMENT ROUTER

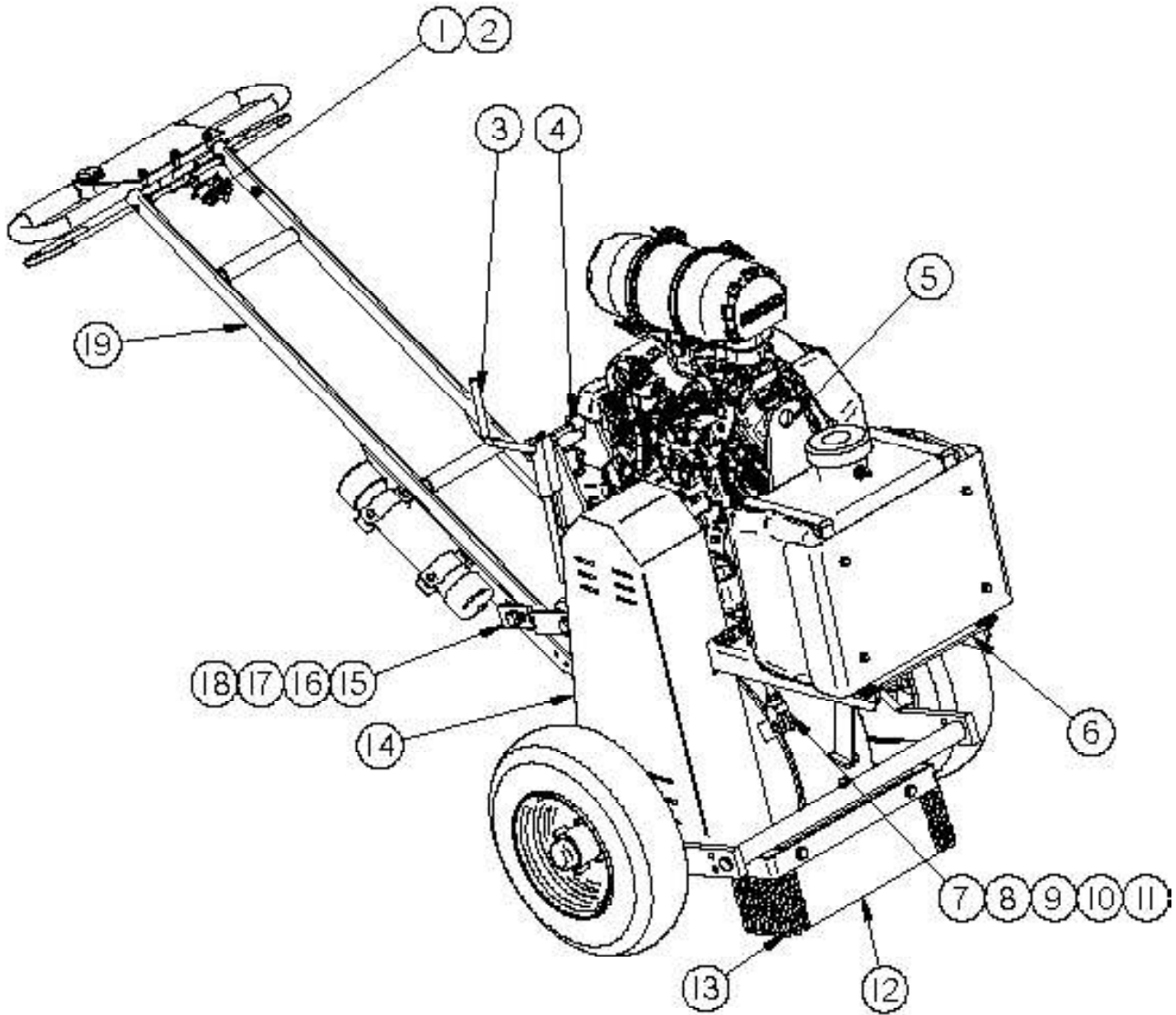

PARTS LIST (Continued)
MODEL 30 PAVEMENT ROUTER

NUMBER	PART NUMBER	QTY	DESCRIPTION
1	31338	1	SWITCH
2	28685	1	STAR WASHER
3	31100	1	PIN REMOVAL TOOL
4	31101	1	PIN RETAINING WRENCH (NOT SHOWN)
5	32199	1	LIFTING BRACKET ASSEMBLY
6	20910	1	ENGINE CHANNEL ASSEMBLY
7	29638	1	COTTER PIN
8	31052	1	CLEVIS PIN
9	31211	1	SPACER
10	28516	1	1/2" JAM NUT
11	29345	1	CLEVIS PIN
12	31102	1	RUBBER ROCK DEFLECTOR
13	31104	1	DEFLECTOR CHAIN ASSEMBLY
14	20940	1	BELT GUARD ASSEMBLY
15	31210	2	HANDLE BRACKET
16	28759	6	1/2" X 1 1/4" GRADE 8 BOLT
17	28528	2	1/2" ESNA NUT
18	28642	8	HARDENED WASHER
19	20903	1	ROCKER SWITCH WIRING HARNESS

PARTS LIST (Continued) MODEL 30 PAVEMENT ROUTER

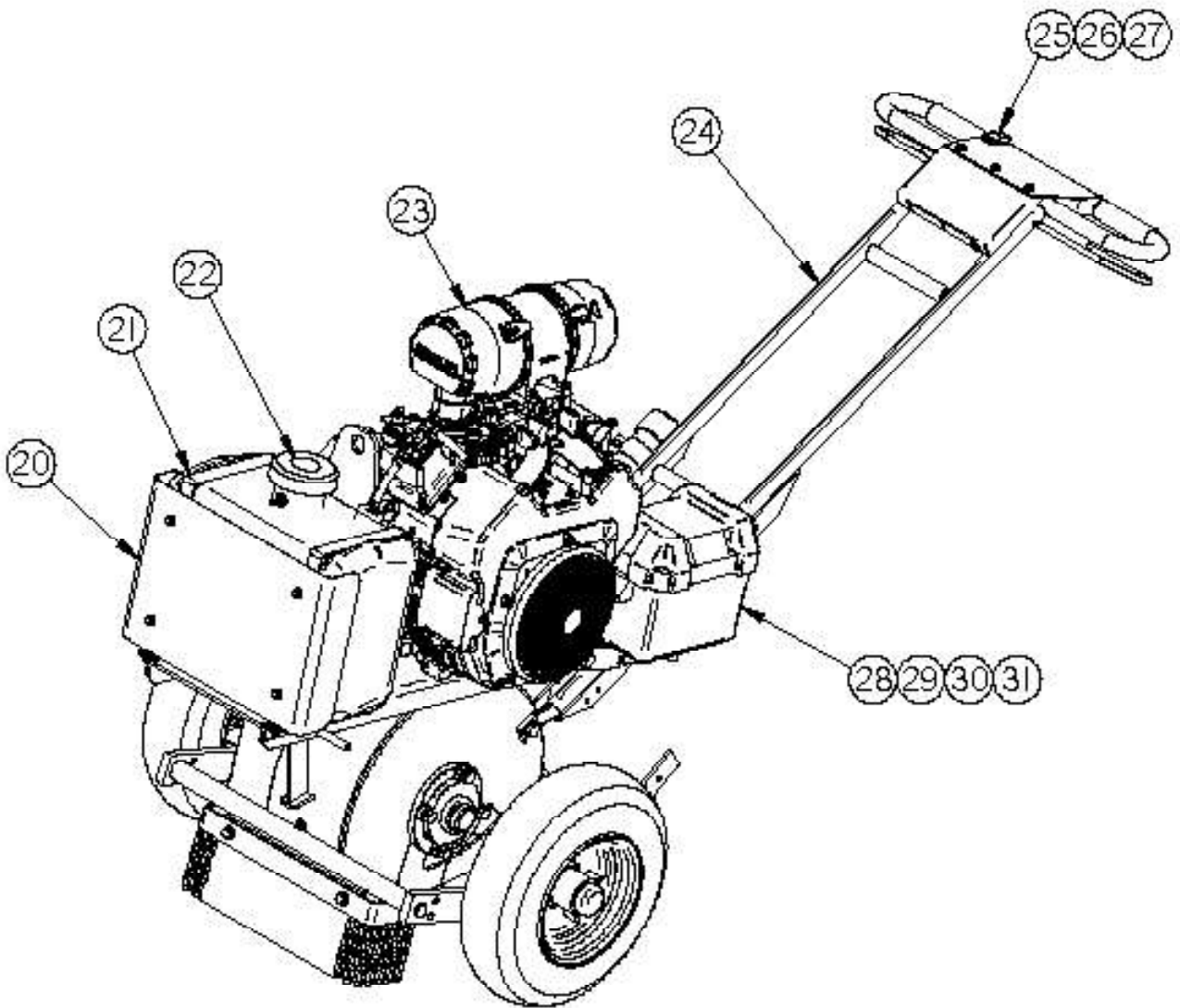

PARTS LIST (Continued)
MODEL 30 PAVEMENT ROUTER

NUMBER	PART NUMBER	QTY	DESCRIPTION
20	20945	1	GAS TANK GAURD
21	20946	2	GAS TANK STRAP ASSEMBLY
22	31442	1	FUEL TANK
23	20914	1	27 HP ENGINE
24	20920	1	HANDLE BAR ASSEMBLY
25	20915	1	ROCKER SWITCH
26	51614	4	14 Ga. SPADE TERMINAL
27	51592	2	10 Ga. SPADE TERMINAL
28	37620	1	BATTERY - 12V
29	24003	1	BATTERY BOX
30	20949	2	BATTERY CABLE GROUND
31	20948	1	BATTERY CABLE POSITIVE

PARTS LIST (Continued) MODEL 30 PAVEMENT ROUTER

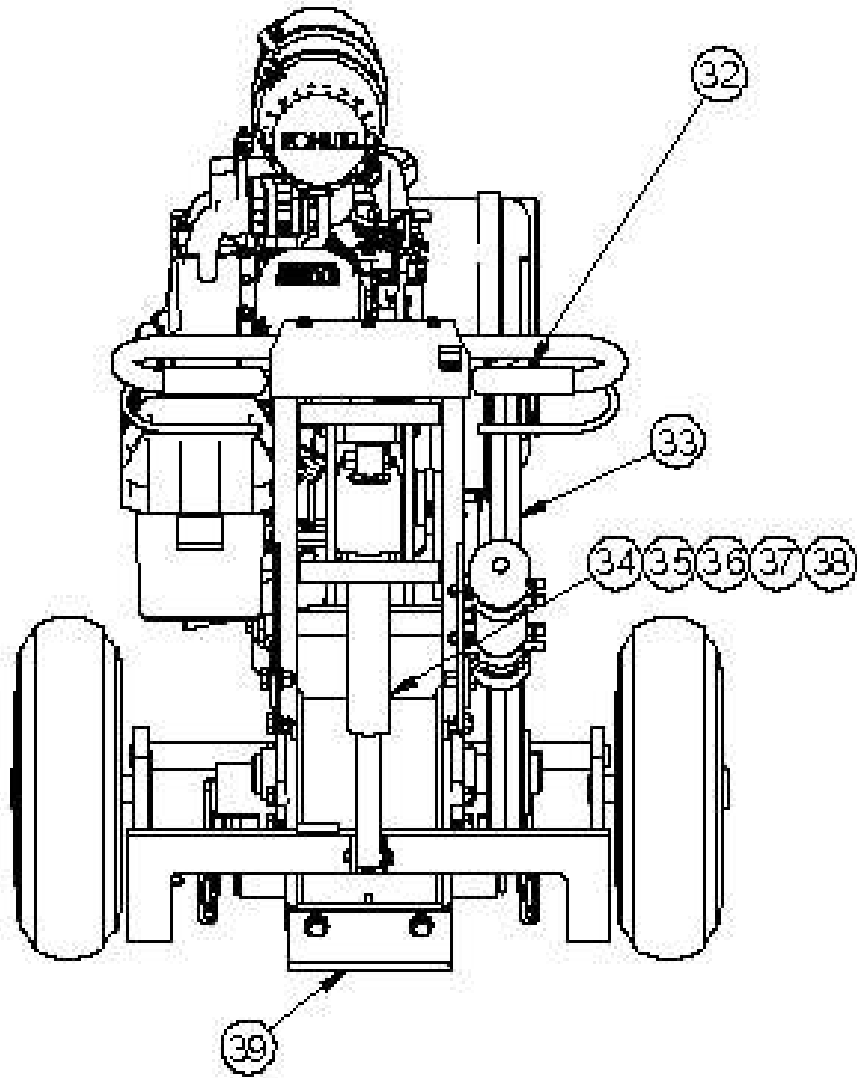

PARTS LIST (Continued)
MODEL 30 PAVEMENT ROUTER

NUMBER	PART NUMBER	QTY	DESCRIPTION
32	20916	2	FOAM HAND GRIP
33	32078	2	BELT 5VX-560
34	32001	1	ACTUATOR
35	32109	2	RUBBER BUSHING
36	31068	1	SHOCK ABSORBER
37	29345	1	1/2 X 2 CLEVIS PIN
38	29638	1	COTTER PIN
39	20919	1	SKID PLATE ASSEMBLY

THIS PAGE INTENTIONALLY LEFT BLANK

MODEL 30 PAVEMENT SELF-PROPELLED ROUTER



DRIVE WHEEL CLUTCH ASSEMBLY MODEL 30 PAVEMENT SELF-PROPELLED ROUTER

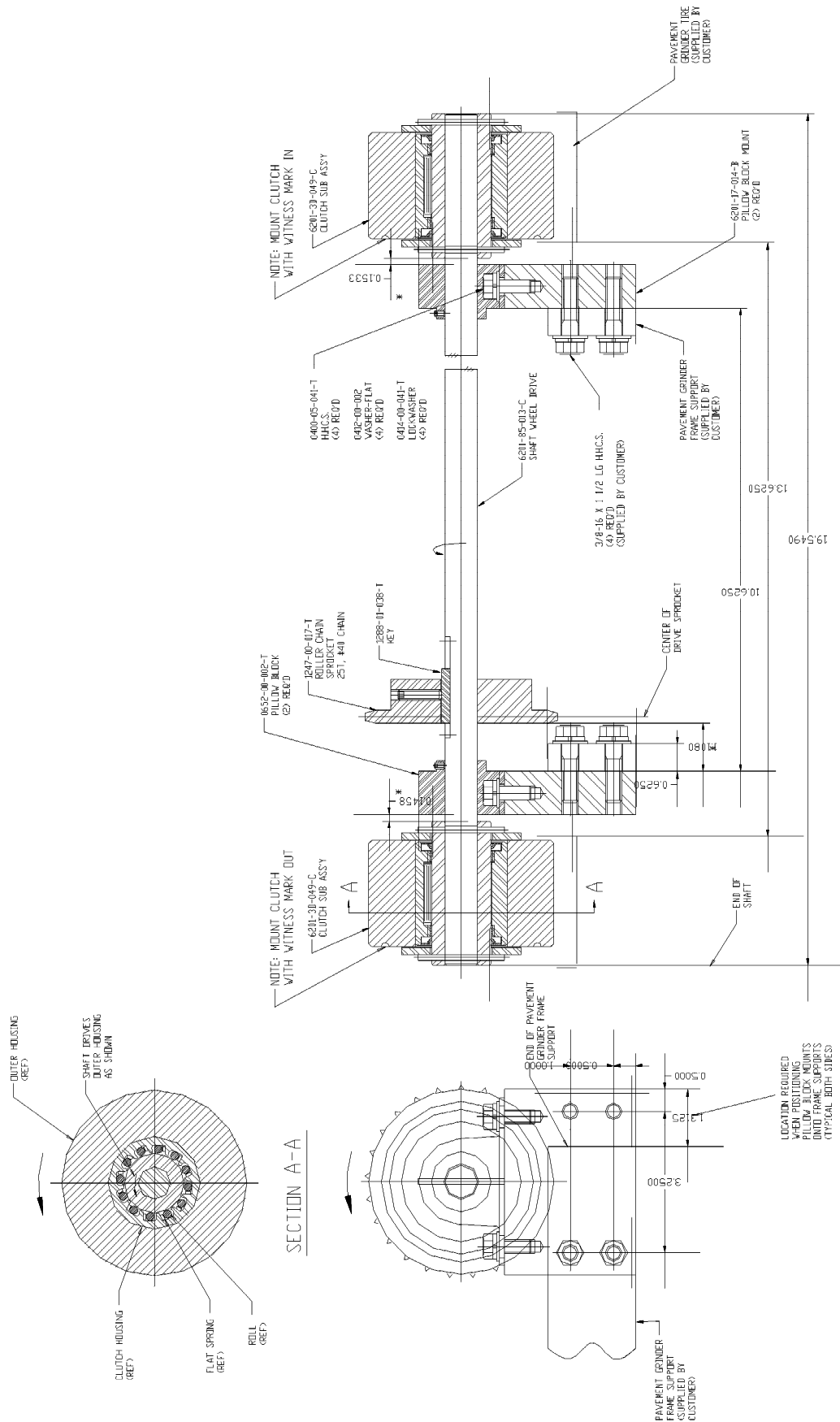

**DRIVE WHEEL CLUTCH ASSEMBLY
MODEL 30 PAVEMENT SELF-PROPELLED ROUTER**



SELF-PROPELLED DRIVE SYSTEM MODEL 30 PAVEMENT SELF-PROPELLED ROUTER

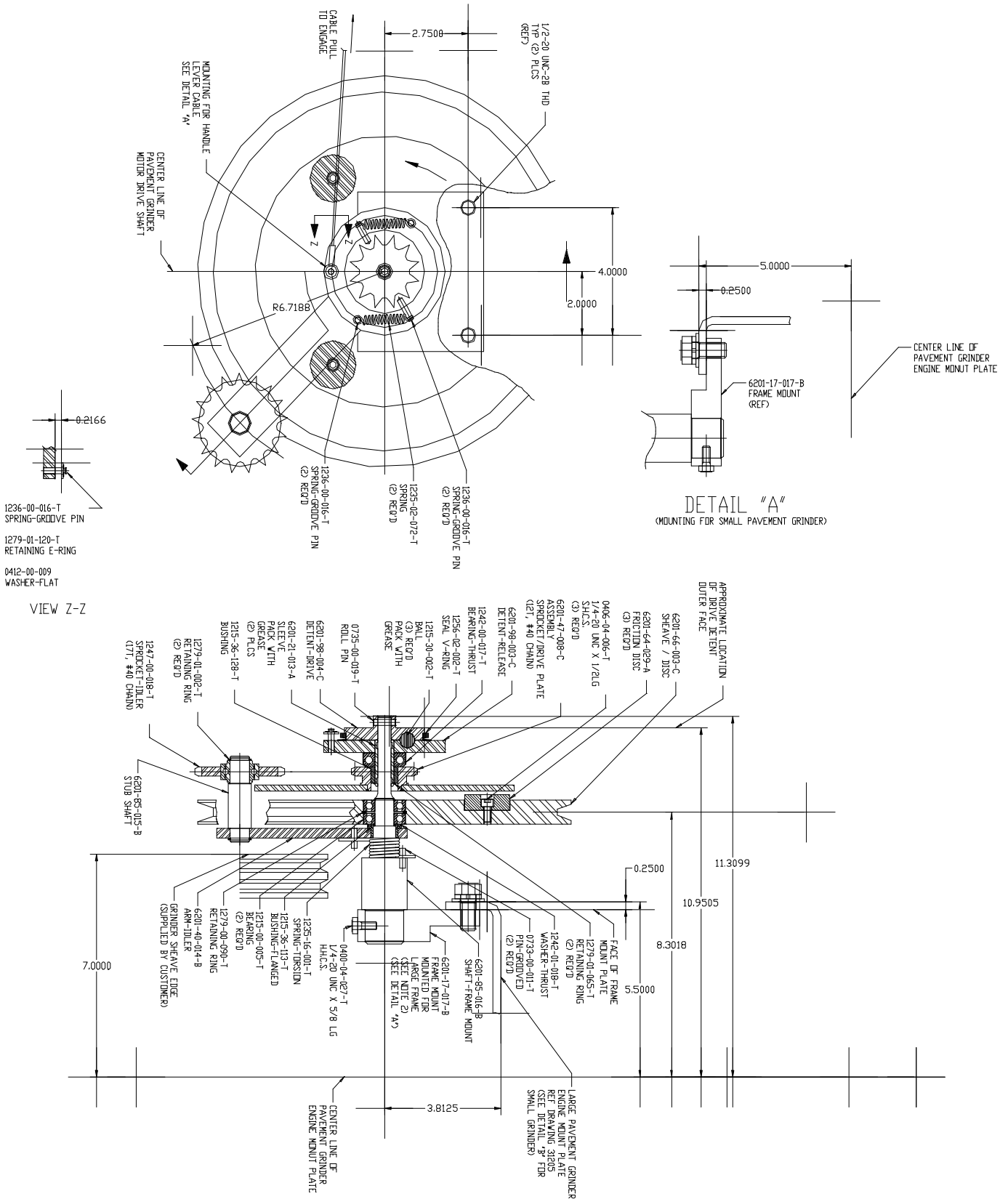

**SELF-PROPELLED DRIVE SYSTEM
MODEL 30 PAVEMENT SELF-PROPELLED ROUTER**



**SELF-PROPELLED HUB/WHEEL SPACER
MODEL 30 PAVEMENT SELF-PROPELLED ROUTER**



NUMBER	PART NUMBER	QTY	DESCRIPTION
----	31483	1	WHEEL SPACER SELF-PROPELLED ROUTER

ENGINE SUPPORT FRAME/CABLE BRACKET HOLDER MODEL 30 PAVEMENT SELF-PROPELLED ROUTER



NUMBER	PART NUMBER	QTY	DESCRIPTION
----	20878	1	LOWER CABLE HOLDER
----	31488	1	CABLE & CABLE GUIDE CLEVIS ASSEMBLY

THIS PAGE INTENTIONALLY LEFT BLANK

MODEL 30 PAVEMENT DUST CONTROL ROUTER



DUST COLLECTION BAG MAINTENANCE

MODEL 30 PAVEMENT DUST CONTROL ROUTER

Dust Collection Bag Maintenance

The dust collection bag should be cleaned on a daily basis or more frequently depending on asphalt conditions to ensure maximum dust collector efficiency. To clean the dust collection bag, remove the dust collection bag from the router. Open the zipper on the dust collection bag to access the inside of the dust collection bag.



Caution:

Dust may collect between the elements or “teeth” of the zipper, making it difficult to open. **Do Not** try to forcibly open the zipper or damage of the dust collection bag may occur. Gently work the slider of the zipper back and forth to work the dust out of the elements until the zipper is completely opened.

Use a Shop Vac to vacuum the entire inside of the dust collection bag. If shop air is to be used to blow dust off of the dust collection bag, use a nozzle that restricts air pressure to no more than 30 psi. Higher pressure than 30 psi. may damage the dust collection bag.

Do Not try to clean the dust collection bag with water. Keep the dust collection bag dry at all times, whether when in use or during transport and storage. Water, rain or significant moisture may cause the bag to shrink and not function appropriately.

Cutter Head Dust Shroud

When seal brushes become worn and stop trapping dust behind the shroud, they should be replaced. If brushes become deformed they can be soaked in hot water for approximately 20 min. This will aid in the brushes regaining their shape. Allow brushes to dry before using. If the shroud is showing wear or damage beyond the extent of brush wear, the entire shroud should be replaced.

Replacing Seal Brushes

To change the seal brushes, remove the long aluminum brush holders from the sides of the shroud. After their removal you will be able to slide the short brushes out of their holders and slide new brushes in. The ends of the aluminum holders for the long brushes have been crimped at the ends. Use a screwdriver or a pair of pliers to spread the ends of the holders apart, then slide the brushes out of the holder. After installing new brushes in the holder, re-crimp the ends in a vice to keep the brushes from sliding out. Reinstall the holders on the shroud. To replace the flexible brush on top of shroud, drill out the rivets with a #30 drill bit. Replace the flexible brush and secure with new 1/8” wide domed blind rivets. (PN 28549)

PARTS LIST CUTTER HEAD DUST SHROUD MODEL 30 PAVEMENT DUST CONTROL ROUTER

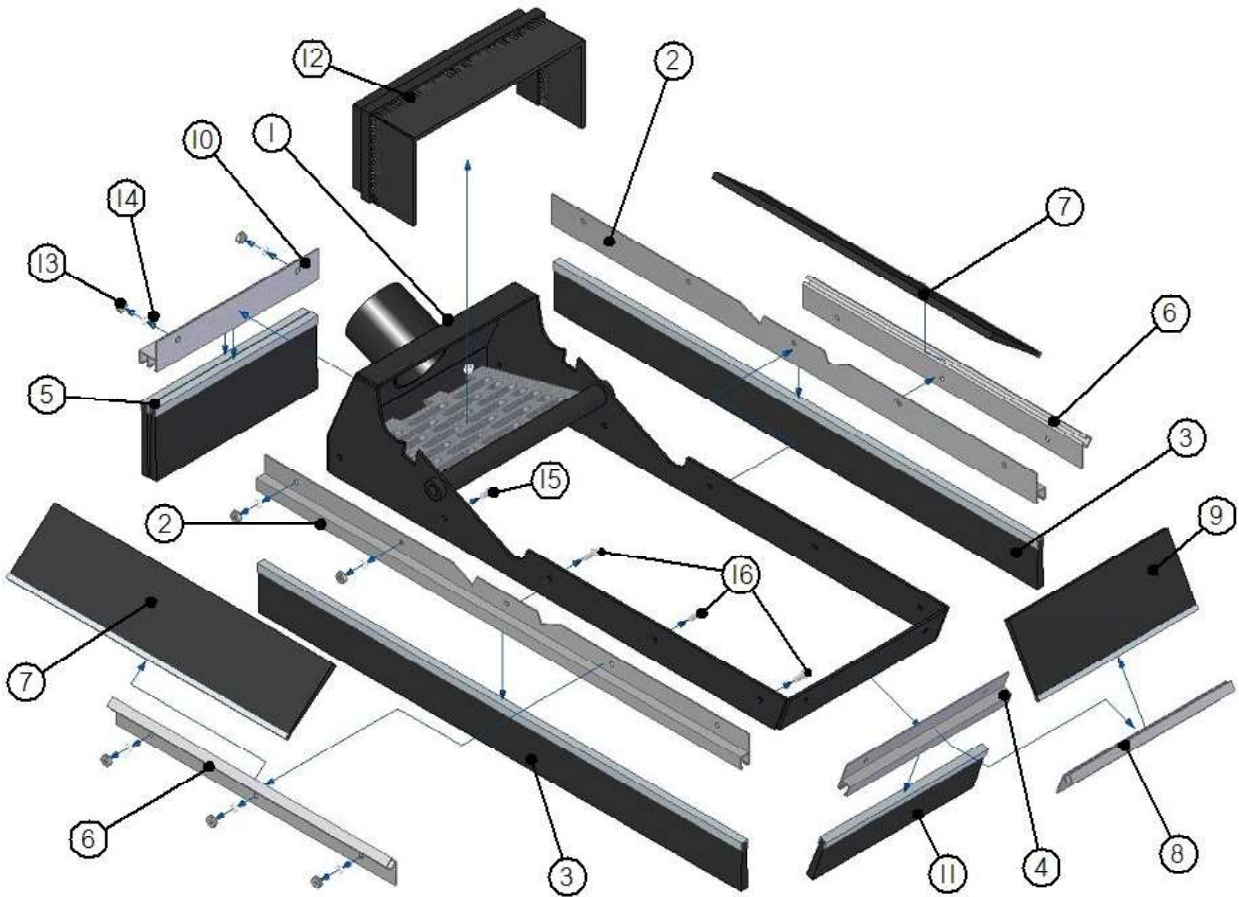

Number	Qty	Part Number	Description
1	1	31580	Dust Shroud Weld Assy
2	2	31586	Brush Holder A
3	2	31591	Strip Brush A
4	1	31587	Brush Holder B
5	2	31592	Strip Brush B
6	2	31588	Brush Holder C
7	2	31593	Strip Brush C
8	1	31589	Brush Holder D
9	1	31594	Strip Brush D
10	1	31599	Brush Holder E
11	1	31595	Strip Brush E
12	1	31596	Flex Brush Seal
13	14	28554	10/32 Hex Nut
14	14	28644	#10 Spring Lock Washer
15	6	28819	10/32 x 3/8" Round Head Screw
16	8	28893	10/32 x 1/2" Round Head Screw
Not Shown	11	28549	1/8 Wide Dome Blind Rivet

PARTS LIST DUST CONTROL MODEL 30 PAVEMENT DUST CONTROL ROUTER

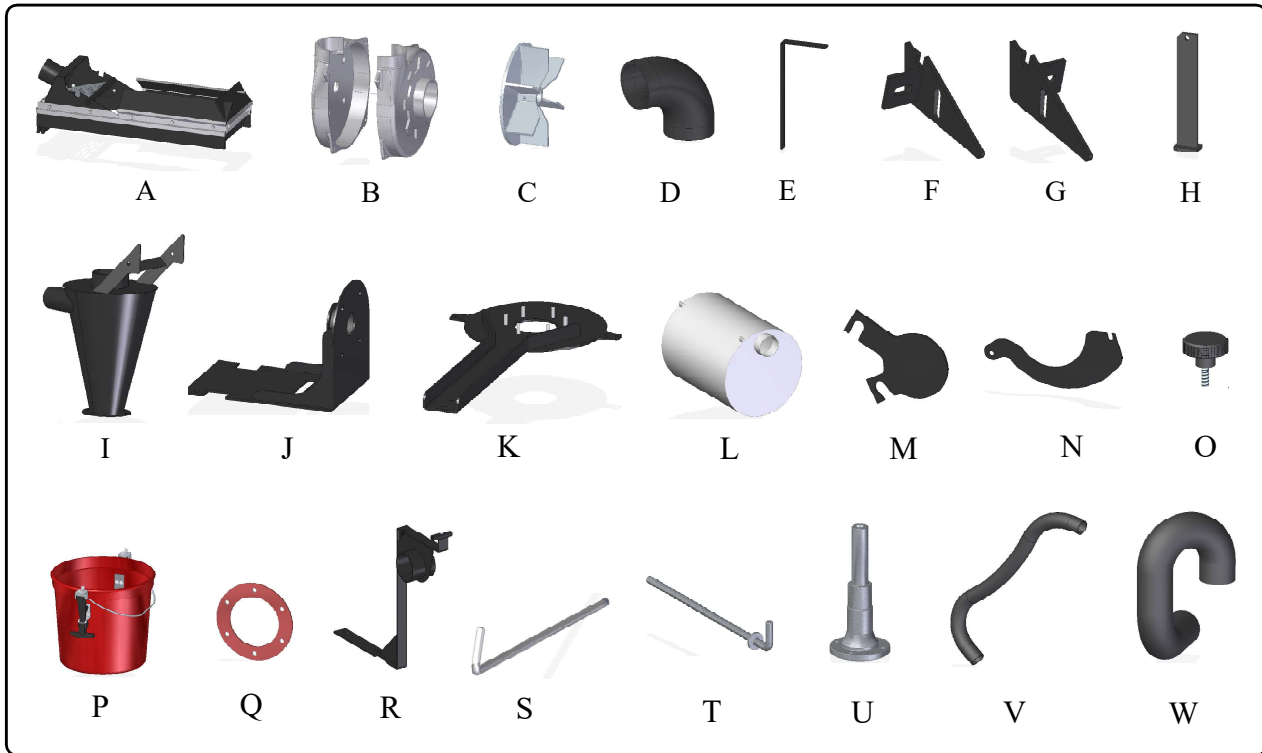

Letter	Qty.	Part Number	Description
A	1	31590	Cutter Head Dust Shroud
B	1	31411	Blower Housing
C	1	31412	Blower Fan
D	1	31415	90° X 4" ID Rubber Elbow
E	1	31409	Brush Manipulation Tool
F	1	31426	Dust Shroud Mnt. Bracket, Left Side
G	1	31427	Dust Shroud Mnt. Bracket, Right Side
H	1	31535	Support Strip Assembly
I	1	31555	Cyclone
J	1	31570	Blower Mounting Bracket Assy.
K	1	31560	Cyclone Mounting Bracket Assy.
L	2	31414	Dust Collection Bag, 12 Sq. Ft.
M	1	31417	Cover, Pin Removal Hole
N	1	31416	Cover, Pin Retaining Hole
O	2	31409	Locking Knob (for filter bag support assy)
P	1	31575	Large Particle Dust Collection Bin
Q	1	31433	Rubber Gasket, Cyclone
R	1	31565	Filter Bag Support Assy.
S	1	31567	Filter Support Rod
T	1	31545	Dust Shroud Retaining Pin
U	1	31413	Kohler Front Drive Shaft
V	1	31437	2 1/2" Suctin Hose
W	1	31438	4" Suction Hose

PARTS LIST DUST CONTROL MODEL 30 PAVEMENT DUST CONTROL ROUTER

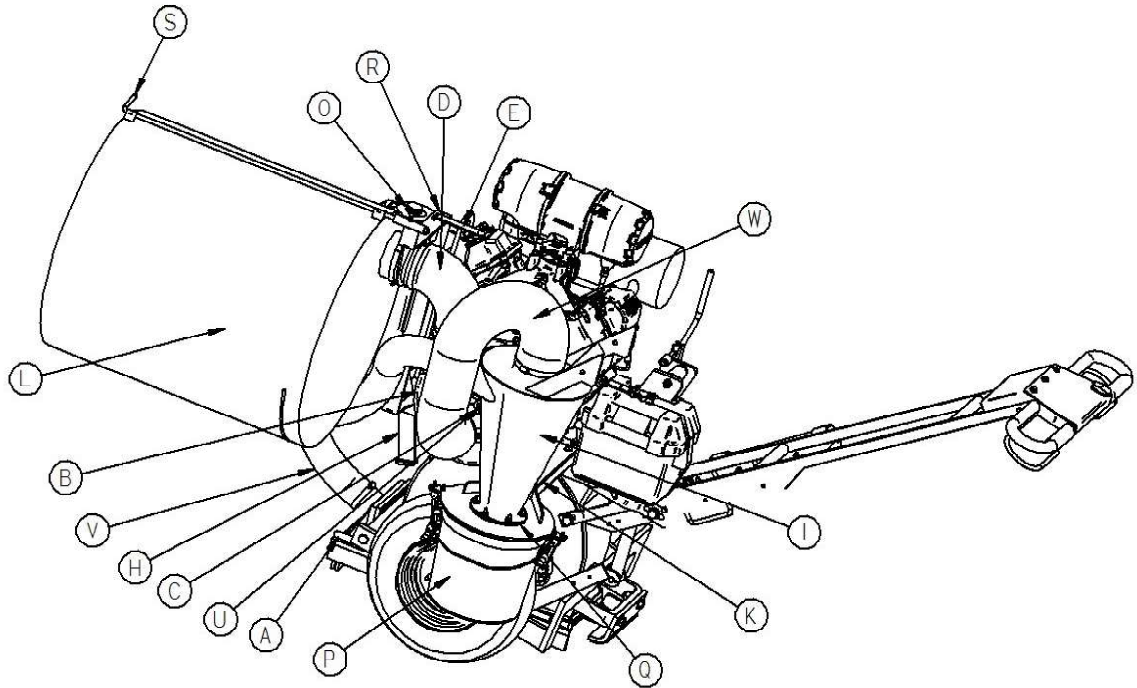

Hardware (Not Shown)

Part Number	Qty	Description
26092	4	Gear Clamp, SAE #64
28500	6	1/4"-20 Hex Nut
28502	8	3/8"-16 Hex Nut
28538	8	3/8"-16 Upset Nut
28540	2	1/2" Upset Nut
28642	4	1/2" Grade 8 Flat Washer
28645	6	1/4" Lock Washer
28646	4	5/16" Lock Washer
28647	8	3/8" Lock Washer
28670	6	1/4" Flat Washer
28672	25	3/8" Flat Washer
28732	4	3/8"-16 x 1 1/4" Bolt
28735	4	3/8"-16 x 2" Bolt
28764	2	1/2"-13 x 2" Bolt
29041	4	M 8-1.25 x 25 mm Bolt
31003	1	Blower Fan Keyway
31407	4	3/8"-16 x 1 1/4" Flat Head Socket Cap Screw
31408	4	3/8"-16 x 1 1/2" Threaded Stud
31418	1	Adjustable Quick Release Gear Clamp
31419	2	Gear Clamp, SAE #40
29657N	1	Coiled Bent-Wire Locking Pin

CRAFCO[®] **INC**
AN **ERGON**  COMPANY

©Copyright 2018 by Crafcoc, Inc.