



**E-Z POUR 200 DIESEL MELTER
WITH PUMP/APPLICATOR**

**PART MANUAL - 26215
REV. A**

Revised: 3/2003

E-Z POUR 200 DIESEL MELTER WITH PUMP/APPLICATOR



TABLE OF CONTENTS

EZ Pour 200 Diesel Melter with Pump Applicator	5
Safety Precautions.....	6-7
Limited Warranty.....	7
Warranty Claim Instructions.....	8
Specifications.....	9
Introduction.....	10
Operating Instructions	
Machine Start Up and Photos.....	11-13
Checking Temperature Control Calibration.....	14
Recalibrating the Temperature Controls.....	14
Loading Machine.....	14
Shutdown & Clean-Out Procedure.....	15
Storing Machine.....	15
Instruction for Ordering Parts.....	15
Maintenance	
Maintenance Instructions.....	16
Maintenance Chart.....	17
General Maintenance Items.....	18
Service Instructions.....	18
Recommended Fluids and Lubricants.....	19
Diesel Burner Electrode Adjustments.....	20
Diesel Burner Settings.....	20
Trouble Shooting	
Trouble Shooting Guide.....	21
Burner Trouble Shooting Guide.....	22
Pump Section Packing Instructions.....	23
Detaching Machine from Vehicle and Setting Up Power Wheel.....	24
Raising Power Wheel and Reattaching Machine to Vehicle.....	24
Diagrams and Parts	
E-Z 200 Diesel Melter Diagram and Parts.....	25-31
Diesel Burner Diagram and Parts.....	32-33
Hydraulic Piping Diagram and Parts - EZ-200 Diesel Melter with Pump/Applicator.....	34-37
Diesel Piping Diagram and Parts - EZ -200 Diesel Melter with Pump /Applicator.....	38-39
Burner Schematic with Shutdown.....	40

E-Z POUR 200 DIESEL MELTER WITH PUMP/APPLICATOR

This manual is furnished with each new **CRAFCO E-Z POUR 200 DIESEL MELTER**. The manual will help your machine operators learn to run the sealer properly and understand its mechanical functions for trouble-free operation.

Your **CRAFCO E-Z POUR 200 DIESEL MELTER** is designed to give excellent service and save maintenance expense. However, as with all specifically engineered equipment, you can get best results at minimum costs if:

- (1) You operate your machine as instructed in this manual, and
- (2) Maintain your machine regularly as stated in this manual.



WARNING: The engine exhaust from this product contains chemicals known to the State of California to cause cancer, birth defects or other reproductive harm. Operate in well ventilated area only. Engine exhaust is deadly.



SAFETY PRECAUTIONS

- High operating temperatures of sealant and machine require protective clothing and gloves be worn by operator.



- Always wear eye protection.

- Observe all **CAUTION AND WARNING** signs posted on machine.



- Avoid the entrance of water into any part of the machine. Water will displace heat transfer oil or sealant, which could be hazardous to personnel surrounding the machine when it reaches operating temperatures.

- Avoid bodily contact with hot sealant material or heat transfer oil, serious burns may result.

- Read Operator Manual thoroughly before operating machine.

- Make sure operator is familiar with machine operation.

- Do not operate in closed building or confined areas.

- Shut-down burner and engine prior to refilling diesel tank.

- When adding solid material to sealant tank, stop mixer, lift lid, place material onto lid and close lid before restarting mixer. Hot material could splash and cause serious burns if this procedure is not followed.

- Keep hands, feet, and clothing away from all moving parts.



- Always keep a fire extinguisher near the unit. Maintain extinguisher properly and be familiar with its use.



- **DO NOT** exceed 525°F. for heat transfer oil temperature.

- **DO NOT** overfill heat transfer oil level. Expansion of oil during heat up could cause overflow. With machine in level position, check oil each day before starting burner, add oil to top mark on dipstick if required (at 70°F.). **Use only recommended heat transfer oil and change after 500 hours of operation or one year, whichever occurs first.**

- Follow operating instructions for starting and shut-down of burner. Instructions are mounted on control box.

- Calibrate temperature control prior to initial operation and each 50 hours of operation.

SAFETY PRECAUTIONS

- Replace any hoses which show signs of wear, fraying, or splitting. Be sure all fittings and joints are tight and leak-proof.

- Precaution is the best insurance against accidents.

- The E-Z Pour 200 Diesel Melter should not be left unattended with burner lit.

- Tighten all bolts and screws after every 100 hours of operation.

- CRAFCO, Inc. assumes no liability for an accident or injury incurred through improper use of the machine.

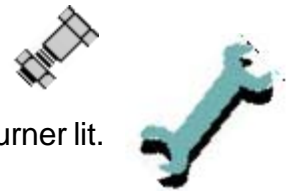

E-Z POUR 200 DIESEL MELTER LIMITED WARRANTY

Crafco, Inc., through its authorized distributor, will replace for the original purchaser free of charge any parts found upon examination by the factory at Mesa, Arizona, to be defective in material or workmanship. This warranty is for a period within 60 days of purchase date, but excludes engine or components, tires, and battery as these items are subject to warranties issued by their manufacturers.

After 60 days, Crafco, Inc., warrants structural parts, excluding heating system, hydraulic components, material pump and hoses, hot oil pump, applicator valves, and electrical components for a period of (1) one year from date of delivery. Crafco, Inc., shall not be liable for parts that have been damaged by accident, alteration, abuse, improper lubrication/maintenance, normal wear, or other cause beyond our control.

The warranty provided herein extends only to the repair and/or replacement of those components on the equipment covered above and does not cover **labor** costs. The warranty does not extend to incidental or consequential damages incurred as a result of any defect covered by this warranty.

All transportation and labor costs incurred by the purchaser in submitting or repairing covered components must be borne by the purchaser.

Crafco, Inc. specifically disavows any other representation, warranty, or liability related to the condition or use of the product.



WARNING: Use of replacement parts other than genuine Crafco parts may impair the safety or reliability of your equipment and nullifies any warranty.

WARRANTY CLAIM INSTRUCTIONS

Please follow the instructions stated below when calling in a Warranty Claim. Failure to follow these procedures may be cause to void the warranty.

1. Call your local CrafcO Distributor. If you do not know who your local distributor is, call a CrafcO Customer Service Representative, (Toll Free 1-800-528-8242) for name, location, and telephone number.
2. On contacting the distributor, be prepared to identify the machine type, model number, and serial number, also, the date of purchase if available.
3. Should the cause of the malfunction be a defective part, the distributor will advise you of the procedure to follow for a replacement.
4. The warranty is valid only for parts, which have been supplied or recommended by CrafcO, Inc.

If you have any additional questions regarding warranty repairs and parts, please do not hesitate to call toll free 1-800-528-8242.

CRAFCO, INCORPORATED
235 SOUTH HIBBERT DRIVE
MESA, AZ. 85210
480-655-8333
Toll Free 1-800-528-8242

SPECIFICATIONS

Vat Capacity.....	200 Gallons
Melt Capacity.....	150 Gallons/Hour
Heat Transfer Oil Required.....	27 Gallons at 70°F
Tank Construction.....	Double Boiler Type
Tank Opening Size.....	16" X 24"
Maximum Heat Input.....	Diesel, Burner- 290,000 BTU
Burner and Temperature Control.....	Thermostatic
Engine - Isuzu.....	3 Cylinder
Model 3LB1	25.4 BHP @ 3000 RPM
Drive Mechanism.....	All Hydraulic with infinite speed forward & reverse action.
Mixer.....	Full Sweep Mixer with 2 horizontal paddles.
Axle (2).....	Dual - 3,500 lbs.capacity
Tires (4).....	185R-14 Load Range D 1850 LBS. @ 65 PSI-capacity each.
Dry Weight.....	Approximately 4,000 lbs.

E-Z POUR 200 DIESEL MELTER OPERATING INSTRUCTIONS

INTRODUCTION

The CRAFCO E-Z Pour 200 Diesel Melter was developed to melt CRAFCO Brand Sealants. However, it will work equally well with all road asphalts and federal specification crack or joint sealants.

DO NOT operate machine without reading operator's manual and being thoroughly familiar with controls:

1. Fill engine fuel tank with diesel fuel (use #1 in cold weather, #2 in warm weather).
2. Check engine crankcase oil (refer to Engine Operator Manual).
3. Check hydraulic fluid level, at ambient temperature. Add fluid if necessary to bring fluid to correct level.
4. Check heat transfer oil level. Check level at ambient temperature, machine level. At 70°F, oil should be at the top mark. **DO NOT** overfill, or spillage may occur when machine reaches operating temperature.
5. All valves should be in closed position and temperature control box set at "**OFF**".
6. Applicator hose can be kept warm and ready for use by storing in heating chamber before using machine. Close heating doors after hose and wand have been coiled in chamber.
7. Check temperature control calibration.



CAUTION:

Extreme care must be used when operating this equipment. Safety is the result of being careful and paying attention to details. Remember the diesel flame is about 2,200°F. Certain exposed parts of this machine, when operating reach 500°F; the sealant as high as 400°F and the hydraulic fluid may reach 200°F. Always wear protective clothing, hard sole shoes, and eye protection. Be sure that all joints and fittings are tight and leak proof. Immediately replace any hose, which shows any signs of wear, fraying, or splitting. Tighten all bolts, nuts, and screws every 250 hours.

MACHINE START UP

TO START BURNER

1. Fully open the damper vent.
2. Set temperature dial to “OFF”.
3. Start engine.
4. Turn temperature dial to desired temperature setting.



CAUTION:

If burner does not ignite the first time, turn temperature dial to off. Turn temperature dial to desired setting. Burner should ignite. If burner still does not ignite, determine cause of malfunction (see [Trouble Shooting Guide](#)).

5. Allow the heating oil to continue to heat. When sealant material reaches a liquid state, engage the agitator by moving the agitator level either forward or backward. If agitator does not move, allow material to heat longer. Jamming of mixer shaft causes hydraulic oil to over heat and machine damage could occur.
6. When sealant reaches correct application temperature, open main tank valve (Page 12, item E), open recirculation valve (Page 12, item B) and close applicator valve (Page 12, item C). Put sealant pump in reverse (Suction) mode. When pump turns freely, reverse sealant pump flow (Discharge) (Page 12, item D). This circulates sealant back into tank.
7. Check the sealant temperature in line (Page 12, item F). This indicates the temperature of sealant flowing through lines. Gauge (Page 13, item C) shows material temperature in tank.
8. When application of sealant is desired, remove the hose from the rear of machine. Attach hose to hand applicator. Be sure to hand tighten only. Place applicator in rear tank opening, with the hand wand valve in the **ON** position.
9. Open applicator valve (Page 12, item C).
10. Close the recirculation valve (Page 12, item B). **IMPORTANT:** Adjust the valve to get the desired amount of flow from the applicator wand given your applicator needs. You do not need to close the valve all the way for application. If material does not flow from wand, the hose may need to be warmed. Heat hose by placing in heating chamber to liquify sealant in hose, then repeat procedure.
11. Extreme care should be taken when changing or installing applicator tips. If the material is hot the material pump **must** be put in the “**SUCTION**” mode. This will insure against hot material pumped from wand. **Sealant material is hot and can cause skin burns.**
12. To apply sealant to joint, remove hand applicator from rear tank opening. **Make sure** the hand wand valve is closed. When applicator wand is over joint, open hand valve and apply sealant.
13. To prevent hose from cooling, place the applicator wand in the rear tank opening when not to be used for 2 minutes or more. Always close hand wand prior to inserting wand in tank opening. Open hand valve to recirculate back into tank and keep hose warm.

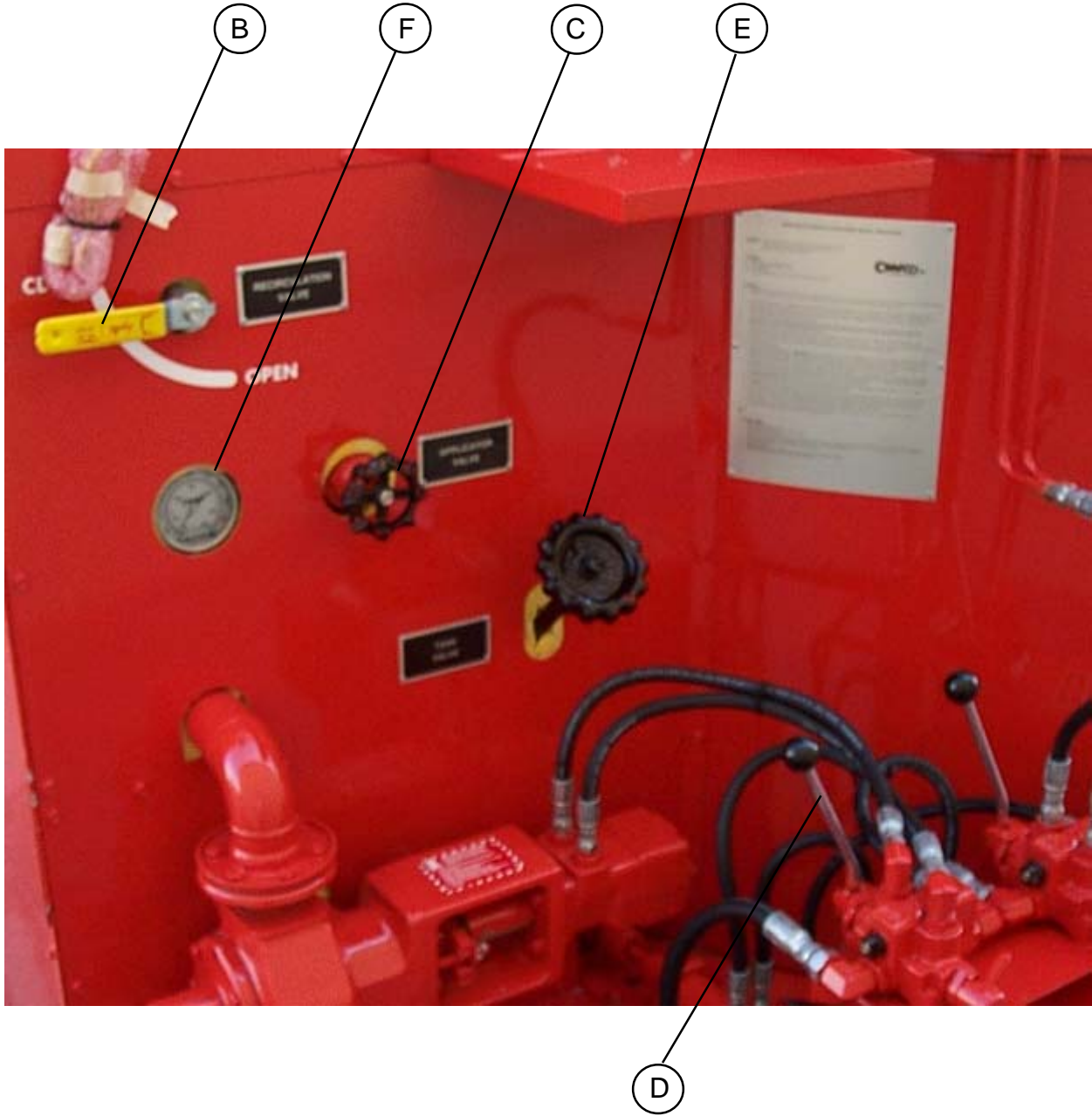



CHECKING TEMPERATURE CONTROL CALIBRATION

The temperature control system is calibrated at the factory during testing; however, it is good practice to check the calibration when the machine is first put into operation and periodically. (Each 50 hours of operation is recommended.) The gauge (Page 13, item A) registers the actual temperature of the heat transfer oil and it should coincide with the temperature control hand knob setting (Page 13, item B).

To check the calibration, first the machine must be level and the following procedure must be followed - check heat transfer oil level, using dipstick. Start up the burner. Set temperature control hand knob at about 250°F. Leave burner on until 200°F. registers on the temperature gauge. Slowly turn the temperature control hand knob down until a click is heard and/or the burner shuts off. If the temperature control hand knob, at this point, reads differently than the temperature gauge, recalibration is required.

RECALIBRATING THE TEMPERATURE CONTROLS

To recalibrate the temperature control, set the temperature control knob to 200°F. When the burner shuts off, carefully pull the hand knob off the spindle. Be careful not to move the spindle during this operation. With a jeweler's screwdriver (or the flattened end of a paper clip) turn the adjusting screw inside the spindle **counterclockwise** to increase temperature or **clockwise** to decrease temperature (1/8 turn will change the temperature 150°F. to 200°F.), carefully replace hand knob. Both the hand knob and the temperature gauge should now read approximately 200°F.



CAUTION:

Extreme care must be used when operating this equipment. Safety is the result of being careful and paying attention to details. Remember the diesel flame is about 2200°F. Certain exposed parts of this machine, when operating, reach 500°F.; the sealant as high as 400°F. and the hydraulic oil may reach 200°F. Always wear protective clothing and eye protection. Be sure that all joints and fittings are tight and leakproof. Immediately replace any hose which shows any signs of wear, fraying or splitting. Tighten all bolts on all flanges after 100 hours. Tighten ALL bolts, nuts and screws every 250 hours.

LOADING THE MACHINE

When loading solid material into the sealant tank, the mixer must be momentarily stopped, the lid lifted, the material placed on the lid and the lid closed again before the mixer is restarted. Following this procedure will prevent the hot material from splashing and causing serious burns to personnel.

The solid material must be added at intervals, which will allow the mixer to rotate without jamming. If blocks of material are fed in too quickly, jamming will result and slow down the melting process. Always try to maintain a melted material level at least 6" above the horizontal portions of the mixer.

SHUTDOWN AND CLEAN-OUT PROCEDURE

1. Turn the temperature dial to “OFF”.
2. Move mixer control valve to “OFF” position.
3. Close recirculation valve.
4. Put material pump in suction mode. With hand applicator valve open, disconnect wand and return hose to heat chamber. Close applicator valve. Open recirculation valve. Close main tank valve.
5. Return material pump control valve to “OFF” position.
6. Turn off engine.
7. Return wand to heat chamber.

STORING MACHINE

The E-Z Pour 200 should be stored with the trailer tongue in an elevated position. This will allow the moisture condensation to settle to the bottom rear of the heat transfer oil tank, above the drain plug. After extended periods of time, the water can be drained by removing the plug and replacing it when all water is displaced.



CAUTION:

If there is any suspicion that moisture is still present after draining, warm heat transfer oil to 300°F for 2 or 3 hours to evaporate any moisture.

INSTRUCTION FOR ORDERING PARTS

Parts may be ordered from your local CRAFCO distributor or directly from CRAFCO, Inc. if a distributor is not available in your area. When ordering parts, give the following information:

1. Part Number
2. Machine Model
3. Serial Number from Name Plate

Write, telephone, or fax:

CRAFCO, INC.
235 SOUTH HIBBERT
MESA, AZ 85210
480-655-8333
480-655-1712
Toll Free: 1-800-528-8242

MAINTENANCE INSTRUCTIONS

ENGINE:

See Engine Owners Manual for operating and maintenance instructions.



HYDRAULIC SYSTEM:

Check hydraulic fluid daily. Change hydraulic filter every 250 hours of operation. Change hydraulic fluid every 500 hours of operation.

HEAT TRANSFER OIL:

Check oil level every 8 hours of operation. Change oil every 500 hours of operation.

WHEEL BEARINGS:

Repack wheel bearings every 24,000 miles or every two years, using a good grade of bearing grease.

LUG NUTS:

Wheel nuts/bolts should be torqued before first road use and after each wheel removal. Check and retorque after the first 10 miles, 25 miles, and again at 50 miles. Check periodically thereafter. Torque in stages. First stage 20-25 ft. lbs., 2nd stage 50-60 ft. lbs., 3rd stage 90-120 ft. lbs.

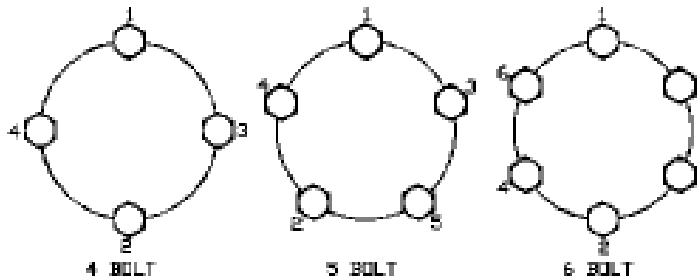

BRAKES:

Check brakes daily. Refer to DEXTER AXLE Operation Maintenance Service Manual located in the manual box.

TONGUE JACK:

Lubricate tongue jack, using a good grade of bearing grease.

SEALANT PUMP:

Adjust pump packing periodically. A slight drip (several drops per minute) should be allowed. Refer to **PUMP SECTION** for details. See page 23.

MAINTENANCE CHART

LOCATION		PROCEDURE	HOURS			
			Daily	50	100	500
Engine check oil level.	Check daily.	*				
Other Engine Maintenance	See Isuzu Operating and Maintenance Instructions.					
Battery	Check water level weekly.					
Pump Packing	Tighten as required. Drip should be several drops/per minute.		*			
Pump Outboard Bearing	Lubricate using a good grade of bearing grease.		*			
Heat Transfer Oil	Check (every 8 hours)		*			
	Change	After 500 hours or 1 year.				
Hydraulic Oil Return Line Filter	First change (250 hours)					
	Subsequent changes (250 hours)			*		
Hydraulic Oil	Check oil (daily).	*				
	Change oil (every 500 hours).				*	
	For proper oil, see recommended fluids & lubricants.					
Burner	Check burner box insulation.				*	
	Clean cad cell.				*	
	Check electrodes.				*	
	Check blower brushes.				*	
	Check nozzle pressure.				*	
Wheel Bearings	Clean & repack - using good grade of bearing grease.	Every 24,000 miles or every two years.				
Tongue Jack	Grease, using good grade of bearing grease.	Once a year.				

GENERAL MAINTENANCE ITEMS

RECOMMENDED QUANTITY	DESCRIPTION	PART NO.
1 Set	Packing, Sealant Pump	29990S
1	Sealant Hose Assembly	27009
1	Engine Oil Filter	43851
1	Engine Fuel Filter	41867
1	Hydraulic Filter	44805
1	Air Filter	43850

SERVICE INSTRUCTIONS

1. Conduct a general inspection of your machine at least once a week. Replace all worn or damaged parts, make any necessary adjustments and tighten all loose nuts or screws.



2. Keep regular replacement items in stock for emergency repairs, to avoid costly "down" time. Refer to General Maintenance Items.
3. Watch for leaks - tighten packing on pumps as necessary.
4. Clean machine externally periodically. Check with sealant manufacturer for recommendation.
5. Follow recommended maintenance procedures on maintenance chart.

RECOMMENDED FLUIDS & LUBRICANTS

APPLICATION	RECOMMENDED	FULL POINT
Engine Oil	Refer to Isuzu Engine Operating Manual.	
Diesel	#1 Cold Climate #2 Warm Climate	30 Gal.
Hydraulic Oil	RONDO OIL-HD-68 Texaco	28 Gal.
Heat Transfer Oil	Regal R&O 68	28 Gal.

The following is a list of suitable Heat Transfer Oils to be used in CrafcO equipment.

PRODUCER	PRODUCT NAME	PRODUCT NO.
Texaco	Regal	R&O 68
Gulf	Harmony	68
Shell	Turbo T	68
Exxon	Teresstic	68
Phillips	Magnus	68
Chevron USA	Heat Transfer Oil #1	
Conoco	Dectol R&O	68
Union Oil	Turbine Oil	68



WARNING:

The Heat Transfer Oil in this machine is a grade that has been tested and recommended by CRAFCO, Inc. The addition of any grade of oil not specifically recommended by CRAFCO, Inc. shall be cause for the warranty to be void. All oils subjected to high temperatures deteriorate with time and lose many of their characteristics. Test conducted by CRAFCO, Inc. have determined that for best results and safety, the Heat Transfer Oil in this machine must be drained and replaced with CrafcO, Inc. recommended oil after five hundred (500) hours of operation or one (1) year, whichever occurs first.

DIESEL BURNER ELECTRODE ADJUSTMENTS

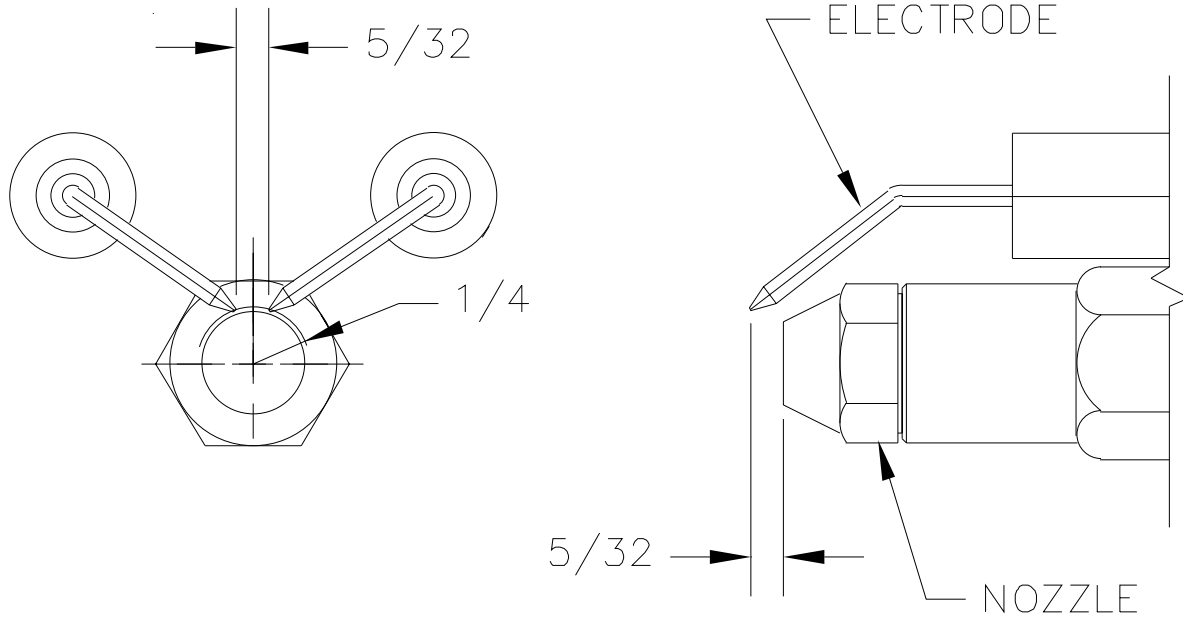

DIESEL BURNER SETTINGS

Air Shutter = 8
Air Band = 0
Fuel Pressure = 140 PSI
Adjustment Plate = 3

TROUBLE SHOOTING GUIDE

PROBLEM	CAUSE	REMEDY
Mixer will not rotate.	Sealant temperature too low.	Continue to heat material.
	Too many blocks placed at one time.	Continue to heat material & try reversing mixer.
	Inadequate hydraulic flow/pressure.	Check hydraulic fluid level. Reset pressure/check flow if necessary.
Material pump will not turn.	Material in tank not to operating temperature.	Continue heating material.
	Inadequate hydraulic, flow/pressure.	Check hydraulic fluid level. Reset pressure/check flow as necessary.
	Material pump damaged or foreign object lodged in pump.	Replace/Remove.
Sealant will not recirculate back into tank through recirculation valve.	Material in tank not to correct temperature.	Continue heating material.
	Drain valve closed.	Open valve.
	Material still cold in suction line. Recirculation valve closed.	Make sure compartment temperature is adequate to melt material. Open valve.
Sealant material flows through recirculation valve but will not flow through application hand wand.	Application valve not open.	Open valve.
	Recirculation valve still open or damaged internally.	Close valve or replace.
	Hose/wand still cold.	Leave in chamber until hot.
When applying sealant it stops flowing from applicator wand.	Hand applicator valve was left in off position too long.	Heat hose by placing in heat chamber to liquify sealant.
	Too many blocks of material added to tank. Cold material entered pump & stopped flow.	Heat hose by placing in heating chamber to liquify sealant.
	Tank fluid level too low for material to flow into pump.	Continue heating material until more liquid material is available.
Pump rotates, but will not pump material.	Material pump worn or damaged.	Replace/Repair.
	Pump rotating in wrong direction.	Reverse control lever.
	Foreign object lodged in inlet line to pump.	Dislodge by reversing pump or disassemble inlet line.
	Material cold, inlet still solid.	Continue to heat material.
Slow heat up of sealant.	Block of sealant over drain.	Dislodge by reversing mixer and pump.
	Build up of coked or crystallized material on inside of material tank.	Allow machine to cool. Remove deposits and flush with solvent.
	Burner not operating.	See Burner Trouble Shooting Guide.
	Low heating oil level.	Make sure fluid level is correct.
	Low heating oil temperature.	Set at recommended temperature.
	Heating oil old or has crystallized.	Replace it as recommended every 500 hours.

BURNER TROUBLE SHOOTING GUIDE

PROBLEM	CAUSE	SOLUTION
Burner blower runs but burner will not light.	Clogged fuel nozzle.	Clean/or replace.
	No fuel in tank, valve at tank shut off, clogged filter or jellied fuel.	Add fuel if necessary open valve, use fuel for anticipated weather.
	Ignitor wires loose, dirty electrodes, faulty transformer.	Check for loose wiring, clean and adjust electrodes, replace transformer if faulty.
	Faulty fuel solenoid, loose wire.	Replace solenoid if necessary tighten all connections.
	Fuel pump at burner needs bleeding.	Open bleeder until fuel runs clear, tighten.
	Cad cell dirty, lens cracked or tape broken in lens.	Clean/Replace.
	Cad cell picking up light from outside of burner housing.	Adjust cad cell bracket to approximately 5° so that it faces downward and close transformer with ear tabs.
	10 amp fuse under DC controller is blown.	Replace.
	Cracked electrodes (ceramic) or not adjusted correctly.	Replace, adjust as per page 20.
	Coupler between fuel pump and blower motor worn, cracked.	Replace.
Excess black smoke in heat compartment and stack.	Air vent incorrectly set.	Set at 8 shutter/band 0.
	Blower motor not running at correct speed.	Charge battery by starting engine.
Burner will ignite and run but will shut "off" and "on" with white smoke coming out of stack.	Air in fuel line.	Check all fuel line fittings, cracks in hoses, and bleed fuel pump to burner.
	Fuel pump pressure low.	Adjust to 140 psi.
Make sure engine is running so battery is fully charged (13V or better).		
Burner lights but shuts down after 15 seconds.	Faulty cad cell, broken, loose cad cell wires, receptacle.	Replace, repair, and tighten all connections.
	Bad connection at key ignition switch to engine and at the circuit breaker near battery.	Replace electrical fittings and check for good connections.
Burner lights but will not relight after temperature drops 20 degrees.	Bad connection at battery, broken or loose wires, faulty manual reset switch, faulty temperature controller, low battery volts.	Clean and retighten, repair or replace, replace switch, recalibrate or replace, recharge battery, tighten belt, check/replace alternator if necessary.
Blower motor will not turn at correct speed or burner will not ignite.	High limit switch.	Check or replace.
	Wires at temperature control box loose or broken.	Check connections or tighten, replace if necessary.
	Battery low, alternator belt loose, alternator failure.	Recharge battery, tighten belt, check/replace alternator if necessary.
	Loose/broken battery cable.	Tighten/replace.
	Engine not running.	Charge battery by starting engine.
	Thermostatic control faulty.	Replace.
Burner will not shut down at set temperature.	Thermostatic control faulty or needs recalibration.	Recalibrate or replace if necessary.

PUMP SECTION PACKING INSTRUCTIONS

Operate the pump under normal conditions and, after a short run-in period, examine packing for leakage. If leakage is excessive tighten locknuts evenly until there is only slight leakage from the packing rings. This slight leakage is a necessary and normal condition for packing and allows for expansion and proper seating.



NOTE:

WHERE LIQUID IS BEING HANDLED, THAT IS HAZARDOUS OR VOLATILE, FULL PRECAUTIONS SHOULD BE TAKEN DURING THE RUN-UP PERIOD.

To replace packing remove key, two nuts and clips, packing gland and packing rings. (Packing hooks are commercially available to assist in removing the packing rings). Clean the shaft and adjacent parts. Examine the shaft, if it is excessively worn or scored, replacement of pump may be necessary.

Insert packing rings, making sure the joints are staggered 180 degrees. Use split ring bushings to seat each ring before adding the next ring. The rings must not be taped or seated in place too tightly. When the packing box is sufficiently full to allow entry of the packing gland (about 1/4") reassemble the packing gland, clips and nuts. Draw up evenly on the packing gland to assure proper seating of the packing, and then loosen nuts about 1/2 turn. Do not cock the packing gland. (This could cause binding or heating of the shaft).

DETACHING MACHINE FROM VEHICLE AND SETTING UP POWER WHEEL (Attachment is optional.)

1. Lower jack and unhitch melter from towing vehicle.
2. Remove hitch receiver from hitch plate.
3. Remove quick release pin from both ends of restraining brace.

 **CAUTION:** Use your legs and not your back or get help to lower the power wheel assembly.

4. After lowering power wheel unit use jack stand to adjust alignment of restraining brace release pin. Make sure all safety pins are installed.
5. After brace is installed, retract jack stand. Pivot jack stand.
6. Plug in control cord.
7. Make sure the Emergency Stop is pulled OUT at all times, even if the machine is parked. It will run the battery down. It should only be used if an emergency stop is needed.



8. Use flow divider at hydraulic pump to control the speed of the power wheel. (maximum setting on flow divider knob should be #3.)
9. Toggle switches on control box control the forward/reverse and left/right direction.

RAISING POWER WHEEL AND REATTACHING MACHINE TO VEHICLE

1. Unplug power cord.
2. Lower jack stand and raise machine to remove weight from power wheel unit. Remove quick pins from both ends of restraining brace.
3. Raise power wheel and install restraining brace on back side of power wheel arm. Reinstall all quick release pins.

 **CAUTION:** Power wheel arm is heavy. Use your legs and not your back or get help in raising unit.

4. Install hitch receiver and lock with lock pin.
5. Attach machine to vehicle. Lower jack/pivot or remove.

E-Z 200 DIESEL MELTER

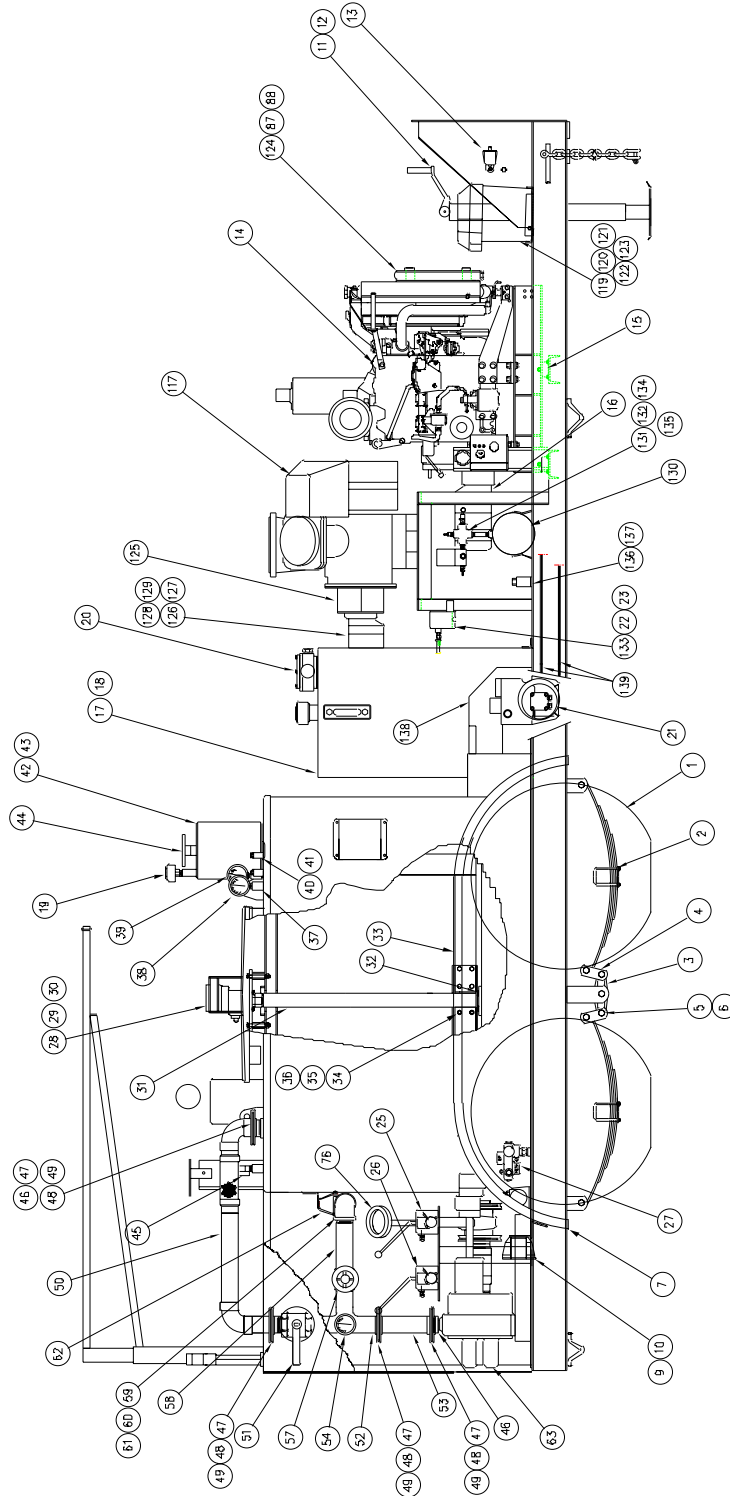

E-Z 200 DIESEL MELTER

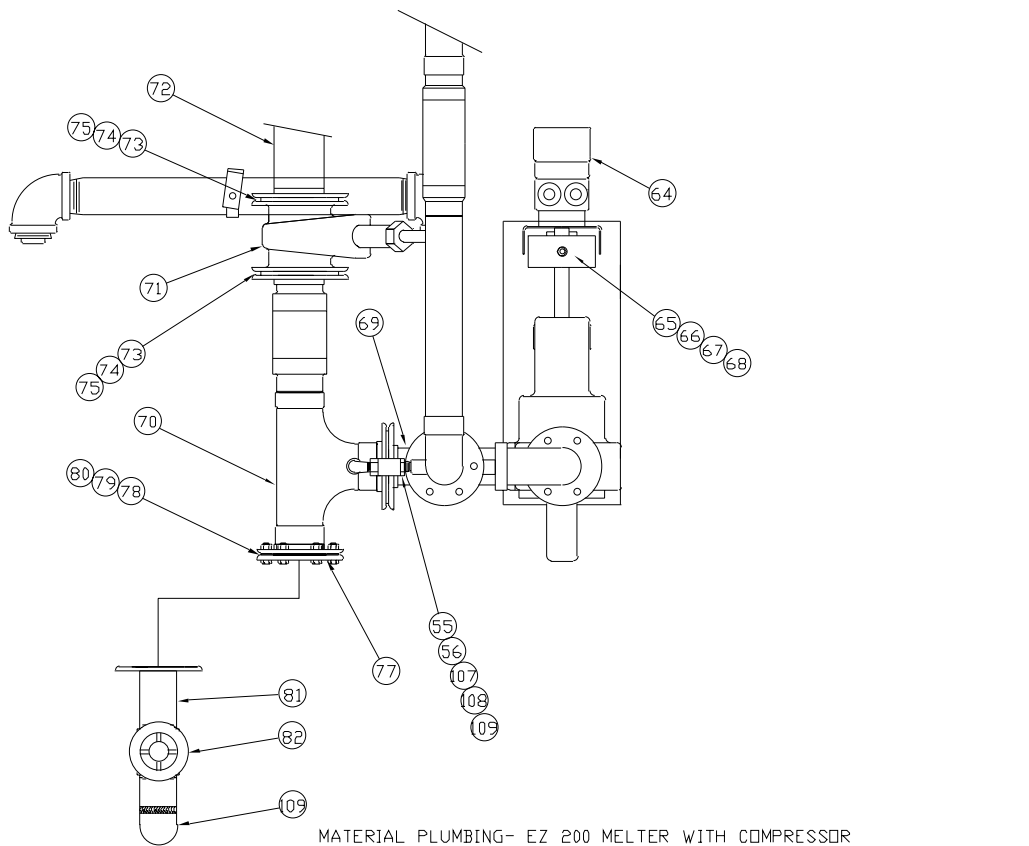
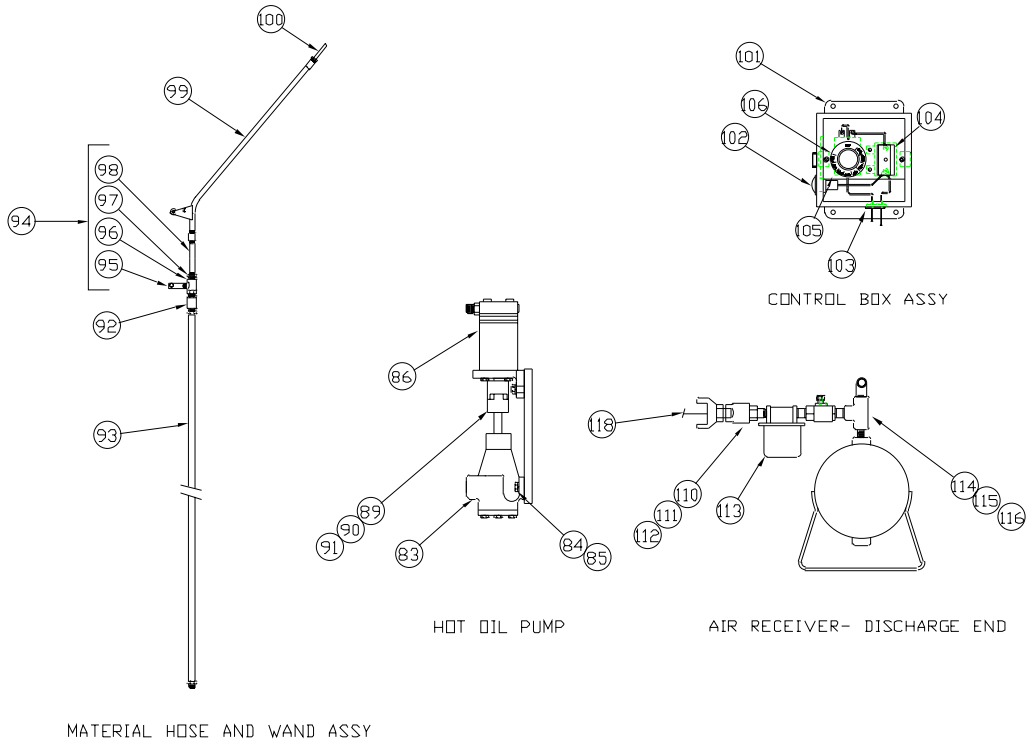

PARTS LIST FOR E-Z 200 DIESEL MELTER

NUMBER	PART NUMBER	QTY	DESCRIPTION
1	41743	4	TIRE AND WHEEL ASSEMBLY - 185 R-14
2	41228	2	AXLE, TORSIONAL 3500#
3	-	-	N/A
4	-	-	N/A
5	-	-	N/A
6	28672	48	3/8 FLAT WASHER
7	41170	1	FENDER (LH)
8	41171	1	FENDER (RH)
9	24022	1	TAIL LIGHT (RH)
10	41171	1	TAIL LIGHT (LH)
11	23097	1	TONGUE JACK, SIDE MOUNT
12	23096	1	JACK SWIVEL BUSHING
13	23117	1	BREAKAWAY SWITCH
14	43075	1	25 HP DIESEL ENGINE
15	29399	4	ISOMOUNT - 3/8 - 16 THREAD
16	41193	1	HYDRAULIC PUMP
17	43591	1	32 GAL DIESEL TANK ASSEMBLY
18	43590	1	32 GAL HYDRAULIC TANK ASSEMBLY
19	26025	1	AIR BREATHER AND ELEMENT 1/2"
20	44805	1	HYDRAULIC FILTER (REPLACEMENT) - NOT SHOWN
21	41891	1	ADC 14 VOLT BURNER
22	41881	1	OIL BURNER NOZZLE (REPLACEMENT) - NOT SHOWN
23	-	-	N/A
24	-	-	N/A
25	41093	1	MIXER CONTROL VALVE

PARTS LIST FOR E-Z 200 DIESEL MELTER

NUMBER	PART NUMBER	QTY	DESCRIPTION
26	41092	1	MATERIAL PUMP CONTROL VALVE
27	41573	1	FLOW DIVIDER PRIORITY
28	40029	1	MOUNTING PLATE
29	40030	4	PIPE SPACER (HYD. MOTOR)
30	22310	1	SPLINED MIXER MOTOR
31	41190	1	MIXER SHAFT - SPLINED
32	28682	2	FLAT WASHER
33	41070	2	PADDLE ASSY.
34	28734	8	3/8" - 16 THREAD X 1-3/4" BOLT
35	28641	16	3/8" FLAT HARDEN WASHER
36	28538	8	3/8" - 16 STOVER C-TOP NUT
37	28178	2	1/2 PIPE COUPLING
38	41243	1	24" TEMPERATURE GAUGE - BTM MNT.
39	40078	1	12" TEMPERATURE GAUGE - BTM MNT.
40	28177	2	3/8 PIPE COUPLING
41	25203	2	STUFFING BOX
42	43355	1	OVERFLOW TANK ASSY.
43	43736	1	AIR RELIEF ASSY.
44	44141	1	DIPSTICK ASSY.
45	25057	1	9" TEMP. GAUGE - BTM MNT.
46	22030	3	FLANGED NIPPLE ASSY.
47	29050	4	FLANGED GASKET - 6 HOLE
48	28731	24	3/8 X 1 BOLT
49	28538	24	3/8 LOCKNUT
50	41678	1	UPPER PIPE ASSEMBLY

PARTS LIST FOR E-Z 200 DIESEL MELTER

NUMBER	PART NUMBER	QTY	DESCRIPTION
51	41246	1	RECIRCULATION VALVE
52	41677	1	FLANGE TEE
53	41134	1	DOUBLE ELBOW ASSY.
54	25050	1	2-1/2 TEMPERATURE GAGE
55	28237	1	3/8 X 90 STREET ELBOW
56	28282	1	3/8 PIPE PLUG
57	29270	1	2" GATE VALVE
58	28110	1	2" X 8" PIPE PLUG
59	28213	2	2" X 90 PIPE ELBOW
60	41291	1	CROSS FEED PIPE
61	28358	1	2 X 1 REDUCING BUSHING
62	26078	1	2" CLEVIS HANGER
63	43140	1	MATERIAL PUMP
64	22027	1	HYDRAULIC MOTOR
65	29202	1	3/8 BALL VALVE
66	28002	1	3/8 CLOSE NIPPLE
67	41697	1	3" ALUMINUM HANDWHEEL
68	28672	56	3/8 FLAT WASHER
69	41133	1	SUCTION LINE
70	41131	1	MATERIAL PIPE SUCTION ASSEMBLY
71	29292	1	3" FLANGED GATE VALVE
72	41039	1	DRAIN PIPE EXT.
73	29060	2	GASKET - 8 HOLE
74	28731	16	3/8 X 1 BOLT
75	28538	16	3/8 LOCKNUT

PARTS LIST FOR E-Z 200 DIESEL MELTER

NUMBER	PART NUMBER	QTY	DESCRIPTION
76	41268	1	VALVE HANDLE EXT.
77	29161	1	BLIND FLANGE
78	41043	2	2-1/2 FLANGE GASKET
79	28731	12	3/8 X 1 BOLT
80	28538	12	3/8 LOCKNUT
81	41929	1	FLANGE ASSEMBLY POUR SPOUT
82	29270	1	2" GATE VALVE
83	41280	1	HOT OIL CIRCULATING PUMP
84	28714	2	5/16 X 3/4 BOLT
85	28646	2	5/16 LOCKWASHER
86	22302	1	HYDRAULIC MOTOR
87	-	-	N/A
88	-	-	N/A
89	41180	1	1/2" BORE COUPLING HALF
90	41695	1	5/8" BORE COUPLING HALF
91	41182	1	SPIDER FOR COUPLING
92	27048	1	MALE/FEMALE SWIVEL
93	27009	1	SEALANT HOSE ASSEMBLY
94	41208	1	HANDLE ASSEMBLY WITH VALVE
95	27080	1	HANDLE ASSEMBLY
96	29240	1	1" BALL VALVE
97	28351	1	1 X 3/4 REDUCING BUSHING
98	28100	1	3/4 X 8 PIPE NIPPLE
99	41629	1	HAND WAND ASSEMBLY
100	27171	1	SEALING TIP ASSEMBLY

PARTS LIST FOR E-Z 200 DIESEL MELTER

NUMBER	PART NUMBER	QTY	DESCRIPTION
101	25286	1	CONTROL BOX ASSEMBLY
102	24140	1	INDICATOR LIGHT
103	26075	1	RUBBER GROMMET
104	25240	1	HIGH LIMIT MANUAL RESET PROBE
105	25276	1	550 ELECTRIC THERMOSTAT
106	25220	1	TEMPERATURE DIAL
107	-	-	N/A
108	-	-	N/A
109	40125	1	SPOUT ASSEMBLY
110	-	-	N/A
111	-	-	N/A
112	-	-	N/A
113	-	-	N/A
114	-	-	N/A
115	-	-	N/A
116	-	-	N/A
117	-	-	N/A

DIESEL BURNER

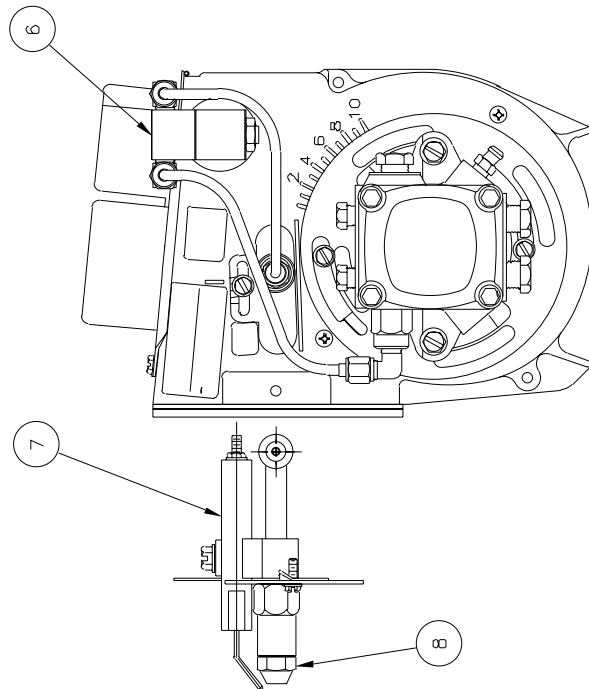
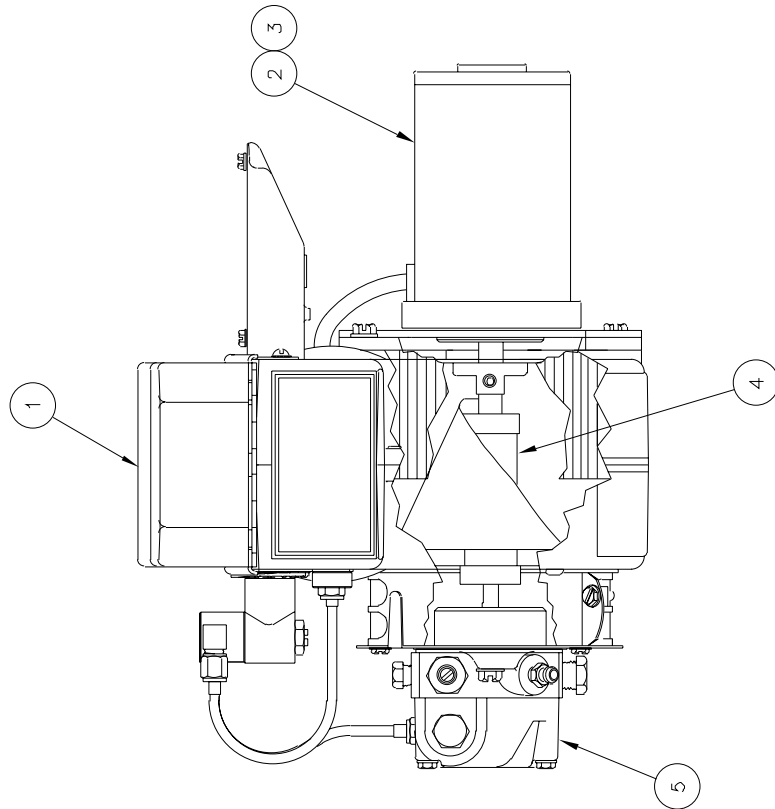

DIESEL BURNER

ITEM	PART NUMBER	QTY	DESCRIPTION
1	41949	-	IGNITION TRANSFORMER
2	41890	-	BLOWER MOTOR
3	41934	-	BRUSH KIT - MOTOR
4	41970	-	COUPLING - FUEL PUMP
5	41979	-	PUMP - FUEL
6	41888	-	SOLENOID - FUEL
7	41993	-	ELECTRODE
8	41881	-	NOZZLE
9	41870	-	CAD EYE (NOT SHOWN)
10	42335	-	DC CONTROLLER (NOT SHOWN)

HYDRAULIC PIPING DIAGRAM E-Z 200 DIESEL MELTER PUMP/APPLICATOR

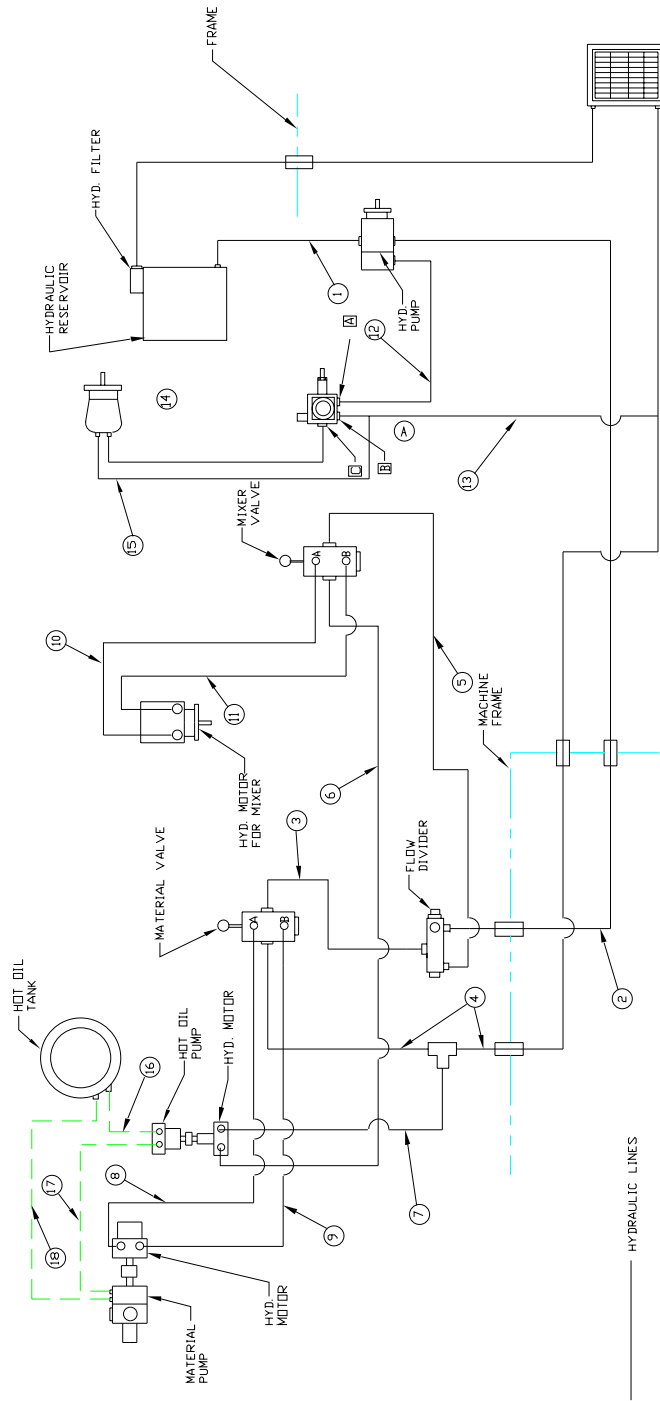

HYDRAULIC PIPING - E-Z POUR 200 DIESEL MELTER

1. HYDRAULIC RESERVOIR TO HYDRAULIC PUMP (SUCTION)		
1	C16-16FJ-20FJ9-34	HYDRAULIC HOSE ASSEMBLY 1" X 34" LONG
1	29824	90° ELBOW ADAPTOR - "O" RING
2. HYDRAULIC PUMP TO FLOW DIVIDER VALVE ("IN" PORT)		
1	29821	STRAIGHT ADAPTOR - "O" RING
1	AX8-10FJ-10FJ-27	HYDRAULIC HOSE ASSEMBLY 1/2 X 27" LONG
REF	29806	BULKHEAD ELBOW
REF	29807	LOCKNUT
REF	41123	TUBE ASSEMBLY (PRESS.)
REF	29805	BULKHEAD CONNECTOR
REF	29807	LOCKNUT
REF	29815	PIPE SWIVEL CONNECTOR
REF	28348	REDUCING BUSHING 3/4 X 1/2
3. FLOW DIVIDER VALVE ("PB" PORT) TO MATERIAL VALVE ("IN" PORT)		
REF	28348	REDUCING BUSHING 3/4 X 1/2
1	29841	STRAIGHT ADAPTOR
1	AX6-6FJ-6FJ-18	HYDRAULIC HOSE ASSEMBLY 3/8 X 18" LONG
4. MATERIAL VALVE ("OUT" PORT) TO HYDRAULIC FILTER (RETURN)		
1	AX8-10FJ-10FJ-22	HYDRAULIC HOSE ASSEMBLY 1/2 X 22" LONG
1	29811	SWIVEL RUN TEE
REF	29805	BULKHEAD CONNECTOR
REF	29807	LOCKNUT
REF	41090	TUBE ASSEMBLY (RETURN)
REF	29806	BULKHEAD ELBOW
REF	29807	LOCKNUT
1	AX8-10FJ-12FJ9-41	HYDRAULIC HOSE ASSEMBLY 1/2 X 41" LONG
REF	29816	STRAIGHT O-RING ADAPTOR
6. FLOW DIVIDER ("REG" PORT) TO MIXER VALVE ("IN" PORT)		
REF	28347	REDUCING BUSHING 3/4 X 3/8
REF	29872	90° ELBOW ADAPTOR
1	AX6-6FJ-6FJ-6FJ-24	HYDRAULIC HOSE ASSEMBLY 3/8 X 24" LONG

HYDRAULIC PIPING - E-Z POUR 200 DIESEL MELTER

7. MIXER VALVE ("OUT" PORT) TO HYDRAULIC MOTOR FOR HOT OIL PUMP (REAR PORT)		
REF	28347	REDUCING BUSHING 3/4 X 3/8
REF	29872	90° ELBOW ADAPTOR
1	AX6-6FJ-6FJ-24	HYDRAULIC HOSE ASSEMBLY 3/8 X 24" LONG
REF	40311	STRAIGHT ADAPTOR "O" RING
8. HYDRAULIC MOTOR FOR HOT OIL PUMP (FRONT PORT) TO TEE IN LINE 4		
REF	40311	STRAIGHT ADAPTOR "O" RING
1	AX6-6FJ-6FJ-18	HYDRAULIC HOSE ASSEMBLY 3/8 X 18" LONG
1	29809	REDUCER 5/8 TO 3/8 TUBE
1	29810	TUBE NUT, 5/8
9. MATERIAL VALVE ("A" PORT) TO HYDRAULIC MOTOR FOR MATERIAL PUMP ("BOTTOM" PORT)		
1	AX6-6FJ-6FJ-24	HYDRAULIC HOSE ASSEMBLY 3/8 X 24" LONG
REF	22029	STRAIGHT ADAPTOR
10. MATERIAL VALVE ("B" PORT) TO HYDRAULIC MOTOR FOR MATERIAL PUMP ("TOP" PORT)		
1	AX6-6FJ-6FJ-24	HYDRAULIC HOSE ASSEMBLY 3/8 X 24" LONG
REF	22029	STRAIGHT ADAPTOR
11. MIXER VALVE ("A" PORT) TO HYDRAULIC MOTOR FOR MIXER (L.H. PORT)		
1	AX6-6FJ-6FJ-18	HYDRAULIC HOSE ASSEMBLY 3/8 X 18" LONG
1	29808	TUBE UNION
REF	41155	TUBE ASSEMBLY - L.H.
REF	22029	STRAIGHT ADAPTOR

HYDRAULIC PIPING - E-Z POUR 200 DIESEL MELTER

12. MIXER VALVE ("B" PORT) TO HYDRAULIC MOTOR FOR MIXER (CURB SIDE PORT)		
1	AX6-6FJ-6FJ-18	HYDRAULIC HOSE ASSEMBLY 3/8 X 18" LONG
1	29808	TUBE UNION
REF	41156	TUBE ASSEMBLY - R.H.
REF	22029	STRAIGHT ADAPTOR
HOT OIL PIPING		
13. HOT OIL TANK (R.H. PORT) TO HOT OIL PUMP (FRONT PORT)-SUCTION		
1	28178	1/2 PIPE COUPLING
1	29844	STRAIGHT ADAPTOR
REF	41060	TUBE ASSEMBLY
REF	29844	STRAIGHT ADAPTOR
14. HOT OIL PUMP (REAR PORT) TO MATERIAL PUMP (TOP PORT)		
1	29844	STRAIGHT ADAPTOR
REF	41061	TUBE ASSEMBLY
1	40316	STRAIGHT ADAPTOR
15. MATERIAL PUMP (TOP PORT) TO HOT OIL TANK (L.H. PORT)		
1	40316	STRAIGHT ADAPTOR
REF	41062	TUBE ASSEMBLY
REF	29844	STRAIGHT ADAPTOR
1	28178	1/2 PIPE COUPLING

DIESEL PIPING DIAGRAM

E-Z 200 DIESEL MELTER WITH PUMP/APPLICATOR

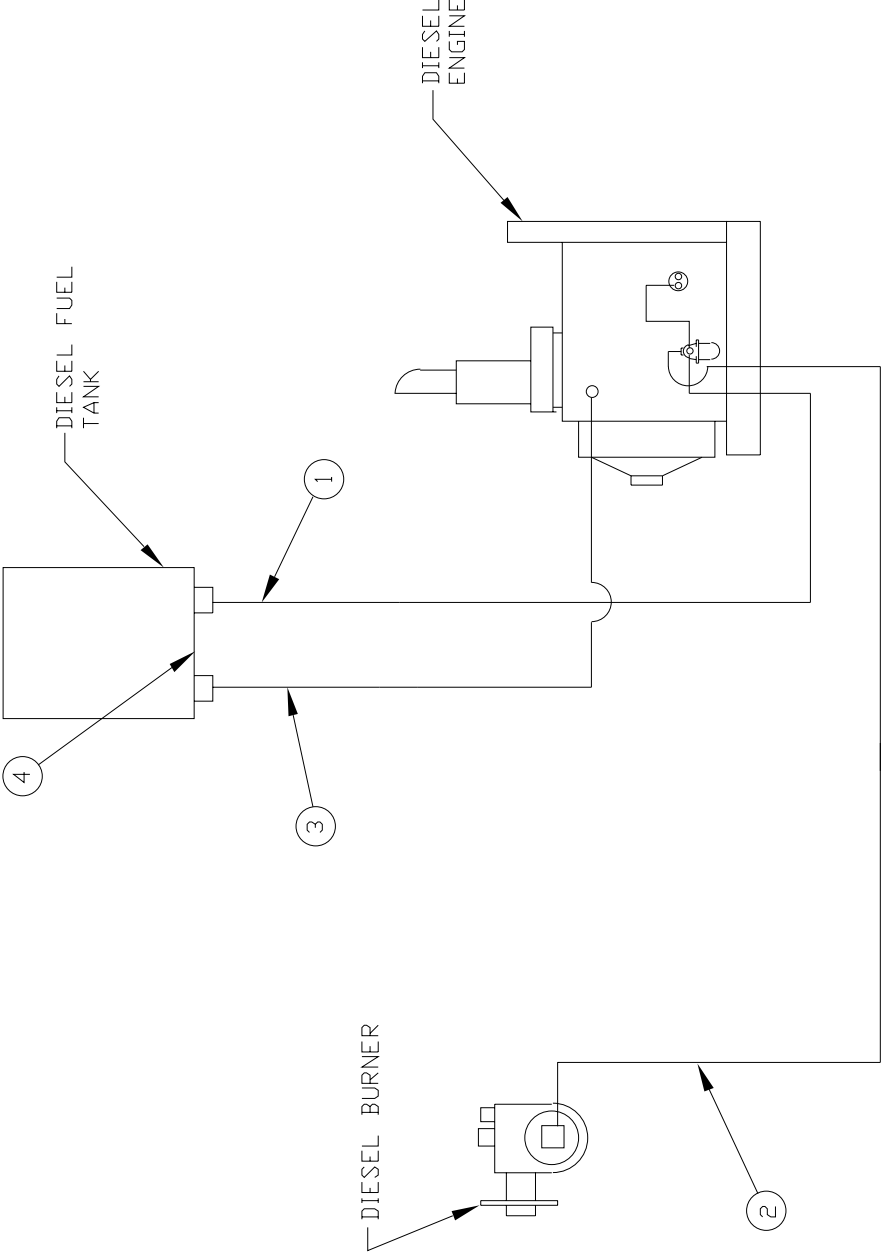

DIESEL PIPING - E-Z 200 DIESEL MELTER WITH PUMP/APPLICATOR

1. DIESEL FUEL TANK TO DIESEL FUEL FILTER		
1	26080	GEAR CLAMP
1	26767	HOSE, PUSH ON SWIVEL
1	26782	HOSE, PUSH ON MALE PIPE 90
1	29591	5/16 X 95" LONG
1	26080	GEAR CLAMP
2. DIESEL FUEL PUMP TO FUEL FILTER		
(SUPPLIED WITH ENGINE)		
3. FUEL FILTER TO DIESEL BURNER		
1	26080	GEAR CLAMP
1	29590	FUEL HOSE 5/16 X 80" LONG
1	26767	HOSE, PUSH ON SWIVEL
1	26782	HOSE, PUSH ON MALE PIPE 90
1	26080	GEAR CLAMP
4. DIESEL ENGINE TO TANK (RETURN)		
1	26080	GEAR CLAMP
1	29592	FUEL HOSE 3/16 X 80" LONG
1	29831	3/16" TUBE ADAPTER
1	29870	FITTING, 90° - 4MJ-4MP
1	26080	GEAR CLAMP

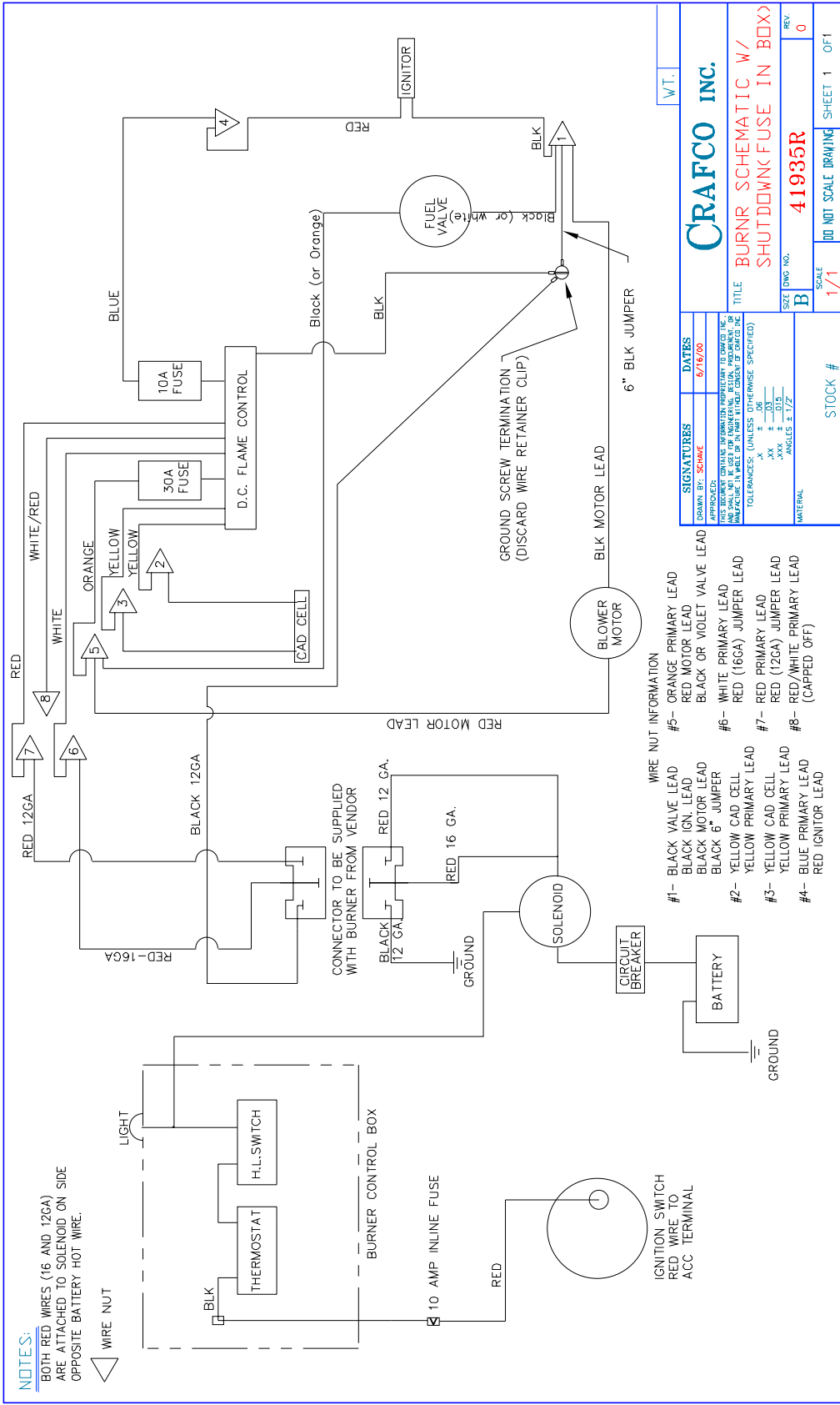

NOTES:

BOTH RED WIRES (16 AND 12GA) ARE ATTACHED TO SOLENOID ON SIDE OPPOSITE BATTERY HOT WIRE.

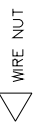

WIRE NUT

- WIRE NUT INFORMATION**
- #1- BLACK VALVE LEAD
 - #2- BLACK IGN. LEAD
 - #3- BLACK MOTOR LEAD
 - #4- BLACK 6" JUMPER
 - #5- YELLOW CAD CELL
 - #6- YELLOW PRIMARY LEAD
 - #7- YELLOW CAD CELL
 - #8- YELLOW PRIMARY LEAD
 - #9- BLUE PRIMARY LEAD
 - #10- RED IGNITOR LEAD

SIGNATURES		DATES	
DRAWN BY: SCHAE		6/16/00	
<small>THIS DOCUMENT CONTAINS PROPRIETARY INFORMATION AND IS THE PROPERTY OF CRAFCO INC. IT IS TO BE KEPT CONFIDENTIAL AND NOT TO BE REPRODUCED OR TRANSMITTED IN ANY FORM OR BY ANY MEANS, ELECTRONIC OR MECHANICAL, INCLUDING PHOTOCOPYING, RECORDING, OR BY ANY INFORMATION STORAGE AND RETRIEVAL SYSTEM.</small>			
<small>TOLERANCES: (UNLESS OTHERWISE SPECIFIED)</small> .XXX ± .03 .XXX ± .015 ANGLES ± 1/2°			
MATERIAL		STOCK #	
B		1/1	
REV: 0		SCALE: 1/1	
SET (DWG NO.): 41935R		JOB NOT SCALE DRAWING	
TITLE: BURNR SCHEMATIC W/ SHUTDOWN FUSE IN BOX		SHEET 1 OF 1	
CRAFCO INC.			
W.T.			

**Pioneering Leadership and
Innovation in Quality
Pavement Maintenance
Products.**



**235 South Hibbert • Mesa, Arizona 85210
480-655-8333 • Watts 1-800-528-8242
Fax 480-655-1712**

© Copyright 2003 by Crafco, Inc.