



E-Z POUR 400 DIESEL MELTER DOUBLE PUMPER

**PART MANUAL - 26231
Rev. A**

Revised: 03/01

E-Z POUR 400 DIESEL MELTER DOUBLE PUMPER



TABLE OF CONTENTS

E-Z Pour 400 Diesel Melter -Double Pumper.....	5
Safety Precautions.....	6-7
Limited Warranty.....	7
Warranty Claim Instructions.....	8
Specifications.....	9
Introduction.....	10
Operating Instructions	
Machine Start Up and Photos.....	11-13
Checking Temperature Control Calibration.....	14
Start Up Procedure for Second Material Pump.....	15
Recalibrating the Temperature Controls.....	16
Loading Machine.....	16
Shutdown & Clean-Out Procedure/Storing Machine.....	17
Instruction for Ordering Parts.....	17
Maintenance	
Maintenance Instructions.....	18
Maintenance Chart.....	19
General Maintenance Items/Service Instructions.....	20
Recommended Fluids and Lubricants.....	21
Diesel Burner Electrode Adjustments/Diesel Burner Settings.....	22
Trouble Shooting	
Trouble Shooting Guide.....	23
Burner Trouble Shooting Guide.....	24
Pump Section Packing Instructions.....	25
Diagrams and Parts	
E-Z 400 Diesel Melter Double Pumper-Diagrams and Parts.....	26-32
Diesel Burner Diagram and Parts.....	33-34
Hydraulic Piping Diagram and Parts.....	35-38
Diesel Piping Diagram and Parts.....	39-40
Burner Schematic with Shutdown.....	41

E-Z POUR 400 DIESEL MELTER DOUBLE PUMPER

This manual is furnished with each new **CRAFCO E-Z POUR 400 DIESEL MELTER - DOUBLE PUMPER**. The manual will help your machine operators learn to run the sealer properly and understand its mechanical functions for trouble-free operation.

Your **CRAFCO E-Z POUR 400 DIESEL MELTER - DOUBLE PUMPER** is designed to give excellent service and save maintenance expense. However, as with all specifically engineered equipment, you can get best results at minimum costs if:

- (1) You operate your machine as instructed in this manual, and
- (2) Maintain your machine regularly as stated in this manual.



WARNING: The engine exhaust from this product contains chemicals known to the State of California to cause cancer, birth defects or other reproductive harm. Operate in well ventilated area only. Engine exhaust is deadly.



SAFETY PRECAUTIONS

- High operating temperatures of sealant and machine require protective clothing and gloves be worn by operator.

- Always wear eye protection.



- Observe all **CAUTION AND WARNING** signs posted on machine.



- Avoid the entrance of water into any part of the machine. Water will displace heat transfer oil or sealant, which could be hazardous to personnel surrounding the machine when it reaches operating temperatures.

- Avoid bodily contact with hot sealant material or heat transfer oil, serious burns may result.

- Read Operator Manual thoroughly before operating machine.

- Make sure operator is familiar with machine operation.

- Do not operate in closed building or confined areas.

- Shut-down burner and engine prior to refilling diesel tanks.

- When adding solid material to sealant tank, stop mixer, lift lid, place material onto lid and close lid before restarting mixer. Hot material could splash and cause serious burns if this procedure is not followed.

- Keep hands, feet, and clothing away from all moving parts.

- Always keep a fire extinguisher near the unit. Maintain extinguisher properly and be familiar with its use.



- **DO NOT** exceed 525° F. for heat transfer oil temperature.

- **DO NOT** overfill heat transfer oil level. Expansion of oil during heat up could cause overflow. With machine in level position, check oil each day before starting burner, add oil to top mark on dipstick if required (at 70° F.). **Use only recommended heat transfer oil and change after 500 hours of operation or one year, whichever occurs first.**

- Follow operating instructions for starting and shut-down of burner. Instructions are mounted on control box.

- Calibrate temperature control prior to initial operation and each 50 hours of operation.

SAFETY PRECAUTIONS

- Replace any hoses which show signs of wear, fraying, or splitting. Be sure all fittings and joints are tight and leak-proof.

- Precaution is the best insurance against accidents.

- The E-Z Pour 400 Diesel Melter should not be left unattended with burner lit.

- Tighten all bolts and screws after every 100 hours of operation.

- CRAFCO, Inc. assumes no liability for an accident or injury incurred through improper use of the machine.

- Refer to Compressor Manual for operating procedures & safety precautions.

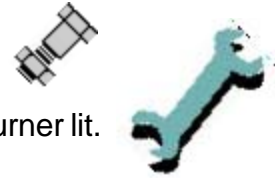

E-Z POUR 400 DIESEL MELTER DOUBLE PUMPER LIMITED WARRANTY

Crafco, Inc., through its authorized distributor, will replace for the original purchaser free of charge any parts found upon examination by the factory at Mesa, Arizona, to be defective in material or workmanship. This warranty is for a period within 60 days of purchase date, but excludes engine or components, tires, and battery as these items are subject to warranties issued by their manufacturers.

After 60 days, Crafco, Inc., warrants structural parts, excluding heating system, hydraulic components, material pump and hoses, hot oil pump, applicator valves, and electrical components for a period of (1) one year from date of delivery. Crafco, Inc., shall not be liable for parts that have been damaged by accident, alteration, abuse, improper lubrication/maintenance, normal wear, or other cause beyond our control.

The warranty provided herein extends only to the repair and/or replacement of those components on the equipment covered above and does not cover **labor** costs. The warranty does not extend to incidental or consequential damages incurred as a result of any defect covered by this warranty.

All transportation and labor costs incurred by the purchaser in submitting or repairing covered components must be bore by the purchaser.

Crafco, Inc. specifically disavows any other representation, warranty, or liability related to the condition or use of the product.



WARNING: Use of replacement parts other than genuine Crafco parts may impair the safety or reliability of your equipment and nullifies any warranty.

WARRANTY CLAIM INSTRUCTIONS

Please follow the instructions stated below when calling in a Warranty Claim. Failure to follow these procedures may be cause to void the warranty.

1. Call your local CrafcO Distributor. If you do not know who your local distributor is, call a CrafcO Customer Service Representative, (Toll Free 1-800-528-8242) for name, location, and telephone number.
2. On contacting the distributor, be prepared to identify the machine type, model number, and serial number, also, the date of purchase if available.
3. Should the cause of the malfunction be a defective part, the distributor will advise you of the procedure to follow for a replacement.
4. The warranty is valid only for parts, which have been supplied or recommended by CrafcO, Inc.

If you have any additional questions regarding warranty repairs and parts, please do not hesitate to call toll free 1-800-528-8242.

CRAFCO, INCORPORATED
235 SOUTH HIBBERT DRIVE
MESA, AZ. 85210
480-655-8333
Toll Free 1-800-528-8242

SPECIFICATIONS

Vat Capacity.....	400 Gallons
Melt Capacity.....	250 Gallons/Hour
Heat Transfer Oil Required.....	55 Gallons at 70° F
Tank Construction.....	Double Boiler Type
Tank Opening Size (2).....	16" X 24"
Maximum Heat Input.....	Diesel, Burner- 400,000 BTU
Burner and Temperature Control.....	Automatic
Engine - Isuzu.....	3 Cylinder 33 HP @ 3000 rpm
Drive Mechanism.....	All hydraulic with infinite speed forward & reverse action.
Mixer.....	Full sweep mixer with 2 blades.
Axle (2).....	5,200 lbs.capacity each.
Tires (4).....	ST 225/78 R15 (Load Range D) (2,300 lbs. capacity each)
Dry Weight.....	Approximately 5,400 lbs.
Diesel Tank	30 Gallons

E-Z POUR 400 DIESEL MELTER DOUBLE PUMPER OPERATING INSTRUCTIONS

INTRODUCTION

The CRAFCO E-Z Pour 400 Diesel Melter Double Pumper was developed to melt CRAFCO Brand Sealants. However, it will work equally well with all road asphalts and federal specification crack or joint sealants.

DO NOT operate machine without reading operator's manual and being thoroughly familiar with controls:

1. Fill engine fuel tank with diesel fuel (use #1 in cold weather, #2 in warm weather).
2. Check engine crankcase oil (refer to Engine Operator's Manual).
3. Check hydraulic fluid level, at ambient temperature. Add fluid if necessary to bring fluid to correct level.
4. Check heat transfer oil level. Check level at ambient temperature, machine level. At 70° F, oil should be at the top mark. **DO NOT** overfill, or spillage may occur when machine reaches operating temperature.
5. All valves should be in closed position and temperature control box set at "**OFF**".
6. Applicator hose can be kept warm and ready for use by storing in heating chamber before using machine. Close heating doors after hose and wand have been coiled in chamber.
7. Check temperature control calibration.
8. Check oil in compressor (refer to Compressor Operator's Manual.)



CAUTION:

Extreme care must be used when operating this equipment. Safety is the result of being careful and paying attention to details. Remember the diesel flame is about 2,200° F. Certain exposed parts of this machine, when operating reach 500° F; the sealant as high as 400° F and the hydraulic fluid may reach 200° F. Always wear protective clothing, hard sole shoes, and eye protection. Be sure that all joints and fittings are tight and leak proof. Immediately replace any hose, which shows any signs of wear, fraying, or splitting. Tighten all bolts, nuts, and screws every 250 hours.

MACHINE START UP

TO START BURNER

1. Fully open the damper vent.
2. Set temperature dial to “OFF”.
3. Start engine.
4. Turn temperature dial to desired temperature setting.



CAUTION:

If burner does not ignite the first time, turn temperature dial to off. Turn temperature dial to desired setting. Burner should ignite. If burner still does not ignite, determine cause of malfunction (see Trouble Shooting Guide).

5. Allow the heating oil to continue to heat. When sealant material reaches a liquid state, engage the agitator by moving the agitator level either forward or backward. If agitator does not move, allow material to heat longer. Jamming of mixer shaft causes hydraulic oil to over heat and machine damage could occur.
6. When sealant reaches correct application temperature, open main tank valve (Page 12, item A), open recirculation valve (Page 12, item B) and close applicator valve (Page 12, item C). Put sealant pump in reverse (Suction) mode. When pump turns freely, reverse sealant pump flow (Discharge) (Page 12, item D). This circulates sealant back into tank.
7. Check the sealant temperature at material pump. This indicates the temperature of sealant flowing through lines.
8. When application of sealant is desired, remove the hose from the rear of machine. Attach hose to hand applicator. Be sure to hand tighten only. Place applicator in rear tank opening, with the hand wand valve in the **ON** position.
9. Open applicator valve (Page 12, item C).
10. Close the recirculation valve (Page 12, item B). **IMPORTANT:** Adjust the valve to get the desired amount of flow from the applicator wand given your applicator needs. You do not need to close the valve all the way for application. If material does not flow from wand, the hose may need to be warmed. Heat hose by placing in heating chamber to liquify sealant in hose, then repeat procedure.
11. Extreme care should be taken when changing or installing applicator tips. If the material is hot the material pump **must** be put in the “**SUCTION**” mode. This will insure against hot material pumped from wand. **Sealant material is hot and can cause skin burns.**
12. To apply sealant to joint, remove hand applicator from rear tank opening. **Make sure** the hand wand valve is closed. When applicator wand is over joint, open hand valve and apply sealant.
13. To prevent hose from cooling, place the applicator wand in the rear tank opening when not to be used for 2 minutes or more. Always close hand wand prior to inserting wand in tank opening. Open hand valve to recirculate back into tank and keep hose warm.



G



H



CHECKING TEMPERATURE CONTROL CALIBRATION

The temperature control system is calibrated at the factory during testing; however, it is good practice to check the calibration when the machine is first put into operation and periodically. (Each 50 hours of operation is recommended.) The gauge (Page 13, item G), registers the actual temperature of the heat transfer oil and it should coincide with the temperature control hand knob setting (Page 13, item H).

To check the calibration, first the machine must be level and the following procedure must be followed - check heat transfer oil level, using dipstick. Start up the burner. Set temperature control hand knob at about 250° F. Leave burner on until 200° F. registers on the temperature gauge. Slowly turn the temperature control hand knob down until a click is heard and/or the burner shuts off. If the temperature control hand knob, at this point, reads differently than the temperature gauge, recalibration is required.

START UP PROCEDURES FOR SECOND MATERIAL PUMP E-Z 400 DOUBLE PUMPER

1. Follow steps numbers 6 through 13 in your Operators Manual page 11 and 12 after you have completed the steps for the first material pump.
2. If the operator does not need to use the second pump through out the day he must still circulate the material in the plumbing of the second pump for approximately 5 minutes so that the material in the pump does not jell or harden from reheating one too many times. Do this at least one time per use of unit.
3. When shutting down the pump follow the steps on page 17, steps 2 through 5.

RECALIBRATING THE TEMPERATURE CONTROLS

To recalibrate the temperature control, set the temperature control knob to 200° F. When the burner shuts off, carefully pull the hand knob off the spindle. Be careful not to move the spindle during this operation. With a jeweler's screwdriver (or the flattened end of a paper clip) turn the adjusting screw inside the spindle **counterclockwise** no more than 1/8 turn to start the burner, to increase the temperature (1/8 turn will raise the temperature 15° F. to 20° F.), continue turning the screw each time the burner cuts out until the gauge reads 200° F. Carefully replace hand knob. Both the hand knob and the temperature gauge should now read approximately 200° F.



CAUTION:

Extreme care must be used when operating this equipment. Safety is the result of being careful and paying attention to details. Remember the diesel flame is about 2200° F. Certain exposed parts of this machine, when operating, reach 500° F.; the sealant as high as 400° F. and the hydraulic oil may reach 200° F. Always wear protective clothing and eye protection. Be sure that all joints and fittings are tight and leakproof. Immediately replace any hose which shows any signs of wear, fraying or splitting. Tighten all bolts on all flanges after 100 hours. Tighten all bolts, nuts and screws every 250 hours.

LOADING THE MACHINE

When loading solid material into the sealant tank, the mixer must be momentarily stopped, the lid lifted, the material placed on the lid and the lid closed again before the mixer is restarted. Following this procedure will prevent the hot material from splashing and causing serious burns to personnel.

The solid material must be added at intervals, which will allow the mixer to rotate without jamming. If blocks of material are fed in too quickly, jamming will result and slow down the melting process.

SHUTDOWN AND CLEAN-OUT PROCEDURE

1. Turn the temperature dial to “OFF”.
2. Move mixer control valve to “OFF” position.
3. Close recirculation valve.
4. Put material pump in suction mode. With hand applicator valve open, disconnect wand and return hose to heat chamber. Close applicator valve. Open recirculation valve. Close main tank valve.
5. Return material pump control valve to “OFF” position.
6. Turn off engine.
7. Return wand to heat chamber.

STORING MACHINE

The E-Z Pour 400 Diesel Double Pumper should be stored in an area to prevent moisture from entering machine. This will allow the moisture condensation to settle to the bottom rear of the heat transfer oil tank, above the drain plug. After extended periods of time, the water can be drained by removing the plug and replacing it when all water is displaced.



CAUTION:

If there is any suspicion that moisture is still present after draining, warm heat transfer oil to 300° F. for 2 or 3 hours to evaporate any moisture.

INSTRUCTION FOR ORDERING PARTS

Parts may be ordered from your local CRAFCO distributor or directly from CRAFCO, Inc. if a distributor is not available in your area. When ordering parts, give the following information:

1. Part Number
2. Machine Model
3. Serial Number from Name Plate

Write, telephone, or fax:

CRAFCO, INC.
235 SOUTH HIBBERT
MESA, AZ 85210
480-655-8333
480-655-1712
Toll Free: 1-800-528-8242

MAINTENANCE INSTRUCTIONS

ENGINE:

- Check engine oil daily. Change after the first 50 hours of operation and change every 100 hours thereafter.
- Change oil filter initially at 50 hours, every 150 hours thereafter.
- See engine owners manual for additional operating and maintenance instructions.



HYDRAULIC SYSTEM:

Check hydraulic fluid daily. Change hydraulic filter after first 250 hours of operating and every 250 hours thereafter. Change hydraulic fluid every 500 hours of operation.

WHEEL BEARINGS:

Repack wheel bearings every 24,000 miles or every two years, using a good grade of bearing grease.

TONGUE JACK:

Lubricate tongue jack, using a good grade of bearing grease.

SEALANT PUMP:

Lubricate outboard bearings using a good grade of bearing grease. Adjust pump packing periodically. A slight drippage (several drops per minute) should be allowed. Refer to Pump Section for details. See page 23.

MAINTENANCE CHART

LOCATION	PROCEDURE	HOURS			
		Daily	50	100	500
Engine check oil level.	Check daily.	*			
Other Engine Maintenance	See Isuzu Operating and Maintenance Instructions.				
Battery	Check water level weekly.				
Pump Packing	Tighten as required. Drip should be several drops/per minute.		*		
Pump Outboard Bearing	Lubricate using a good grade of bearing grease.		*		
Heat Transfer Oil	Check (every 8 hours)		*		
	Change	After 500 hours or 1 year.			
Hydraulic Oil Return Line Filter	First change (250 hours)				
	Subsequent changes (250 hours)				
Hydraulic Oil	Check oil (daily).	*			
	Change oil (every 500 hours).				*
	For proper oil, see recommended fluids & lubricants.				
Burner	Check burner box insulation.				*
	Clean cad cell.				*
	Check electrodes.				*
	Check blower brushes.				*
	Check nozzle pressure.				*
Wheel Bearings	Clean & repack - using good grade of bearing grease.	Every 24,000 miles or every two years.			
Tongue Jack	Grease, using good grade of bearing grease.	Once a year.			

GENERAL MAINTENANCE ITEMS

RECOMMENDED QUANTITY	DESCRIPTION	PART NO.
1 Set	Packing, Sealant Pump	29990
1	Sealant Hose Assembly	27009
1	Engine Oil Filter	41869
1	Engine Fuel Filter	41867
1	Hydraulic Filter	44805
1	Air Filter	41868

SERVICE INSTRUCTIONS

1. Conduct a general inspection of your machine at least once a week. Replace all worn or damaged parts, make any necessary adjustments and tighten all loose nuts or screws.

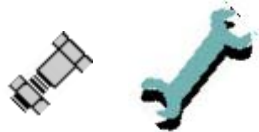

2. Keep regular replacement items in stock for emergency repairs, to avoid costly "down" time. Refer to General Maintenance Items.
3. Watch for leaks - tighten packing on pumps as necessary.
4. Clean machine externally periodically. Check with sealant manufacturer for recommendation.
5. Follow recommended maintenance procedures on maintenance chart.

RECOMMENDED FLUIDS & LUBRICANTS

APPLICATION	RECOMMENDED	FULL POINT
Engine Oil	Refer to Isuzu Engine Operating Manual.	
Diesel	#1 Cold Climate #2 Warm Climate	30 Gal.
Hydraulic Oil	RONDO OIL-HD-68 Texaco	28 Gal.
Heat Transfer Oil		51 Gal.

The following is a list of suitable Heat Transfer Oils to be used in CrafcO equipment.

PRODUCER	PRODUCT NAME	PRODUCT NO.
Texaco	Regal	R&O 68
Gulf	Harmony	68
Shell	Thermia	"C"
Exxon	Teresstic	68
Phillips	Magnus	68
Chevron USA	Heat Transfer Oil #1	
Conoco	Dectol R&O	68
Union Oil	Turbine Oil	68



WARNING:

The Heat Transfer Oil in this machine is a grade that has been tested and recommended by CRAFCO, Inc. The addition of any grade of oil not specifically recommended by CRAFCO, Inc. shall be cause for the warranty to be void.

All oils subjected to high temperatures deteriorate with time and lose many of their characteristics. Test conducted by CRAFCO, Inc. have determined that for best results and safety, the Heat Transfer Oil in this machine must be drained and replaced with CrafcO, Inc. recommended oil after five hundred (500) hours of operation or one (1) year, whichever occurs first.

DIESEL BURNER ELECTRODE ADJUSTMENTS

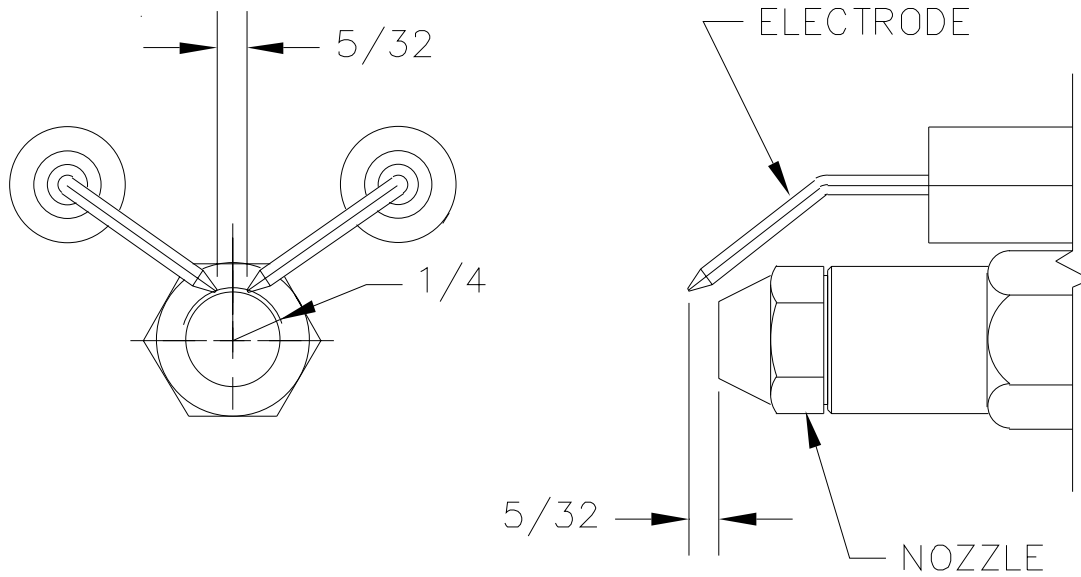

DIESEL BURNER SETTINGS

Air Shutter = 5
Air Band = 5
Fuel Pressure = 140 PSI
Adjustment Plate = 3

TROUBLE SHOOTING GUIDE

PROBLEM	CAUSE	REMEDY
Mixer will not rotate.	Sealant temperature too low.	Continue to heat material.
	Too many blocks placed at one time.	Continue to heat material & try reversing mixer.
	Inadequate hydraulic flow/pressure.	Check hydraulic fluid level. Reset pressure/check flow if necessary.
Material pump will not turn.	Material in tank not to operating temperature.	Continue heating material.
	Inadequate hydraulic, flow/pressure.	Check hydraulic fluid level. Reset pressure/check flow as necessary.
	Material pump damaged or foreign object lodged in pump.	Replace/Remove.
Sealant will not recirculate back into tank through recirculation valve.	Material in tank not to correct temperature.	Continue heating material.
	Drain valve closed.	Open valve.
	Material still cold in suction line. Recirculation valve closed.	Make sure compartment temperature is adequate to melt material. Open valve.
Sealant material flows through recirculation valve but will not flow through application hand wand.	Application valve not open.	Open valve.
	Recirculation valve still open or damaged internally.	Close valve or replace.
	Hose/wand still cold.	Leave in chamber until hot.
When applying sealant it stops flowing from applicator wand.	Hand applicator valve was left in off position too long.	Heat hose by placing in heat chamber to liquify sealant.
	Too many blocks of material added to tank. Cold material entered pump & stopped flow.	Heat hose by placing in heating chamber to liquify sealant.
	Tank fluid level too low for material to flow into pump.	Continue heating material until more liquid material is available.
Pump rotates, but will not pump material.	Material pump worn or damaged.	Replace/Repair.
	Pump rotating in wrong direction.	Reverse control lever.
	Foreign object lodged in inlet line to pump.	Dislodge by reversing pump or disassemble inlet line.
	Material cold, inlet still solid.	Continue to heat material.
	Block of sealant over drain.	Dislodge by reversing mixer and pump.
Slow heat up of sealant.	Build up of coked or crystallized material on inside of material tank.	Allow machine to cool. Remove deposits and flush with solvent.
	Burner not operating.	See Burner Trouble Shooting Guide.
	Low heating oil level.	Make sure fluid level is correct.
	Low heating oil temperature.	Set at recommended temperature.
	Heating oil old or has crystallized.	Replace it as recommended every 500 hours.

BURNER TROUBLE SHOOTING GUIDE

PROBLEM	CAUSE	SOLUTION
Blower motor will not turn at correct speed or burner will not ignite.	1. High limit switch.	1. Check or replace.
	2. Wires at temperature control box loose or broken.	2. Check connections or tighten, replace if necessary.
	3. Battery low, alternator belt loose, alternator failure.	3. Recharge battery, tighten belt, check/replace alternator if necessary.
	4. Loose/broken battery cable.	4. Tighten/replace.
	5. Engine not running.	5. Charge battery by starting engine.
	6. Thermostatic control faulty.	6. Replace.
Burner will not shut down at set temperature.	Thermostatic control faulty or needs recalibration.	Recalibrate or replace if necessary.
Make sure engine is running so battery is fully charged.		
Burner blower runs but burner will not light.	1. Clogged fuel nozzle.	1. Check or replace.
	2. No fuel in tank, valve at tank shut off, clogged filter or jellied fuel.	2. Add fuel if necessary open valve, use fuel for anticipated weather.
	3. Igniter wires loose, dirty ignitors, faulty transformer.	3. Check for loose wiring, clean and adjust ignitors, replace transformer if faulty.
	4. Faulty fuel solenoid, loose wire.	4. Replace solenoid if necessary tighten all connections.
	5. Fuel pump at burner needs bleeding.	5. Open bleeder until fuel runs clear, tighten.
Excess smoke in heat compartment.	1. Air vent incorrectly set.	1. Set at 5.
	2. Blower motor not running at correct speed.	2. Charge battery by starting engine.

PUMP SECTION PACKING INSTRUCTIONS

Operate the pump under normal conditions and, after a short run-in period, examine packing for leakage. If leakage is excessive tighten locknuts evenly until there is only slight leakage from the packing rings. This slight leakage is a necessary and normal condition for packing and allows for expansion and proper seating.



NOTE:

WHERE LIQUID IS BEING HANDLED, THAT IS HAZARDOUS OR VOLATILE, FULL PRECAUTIONS SHOULD BE TAKEN DURING THE RUN-UP PERIOD.

To replace packing remove key, two nuts and clips, packing gland and packing rings. (Packing hooks are commercially available to assist in removing the packing rings). Clean the shaft and adjacent parts. Examine the shaft, if it is excessively worn or scored, replacement of pump may be necessary.

Insert packing rings, making sure the joints are staggered 180 degrees. Use split ring bushings to seat each ring before adding the next ring. The rings must not be taped or seated in place too tightly. When the packing box is sufficiently full to allow entry of the packing gland (about 1/4") reassemble the packing gland, clips and nuts. Draw up evenly on the packing gland to assure proper seating of the packing, and then loosen nuts about 1/2 turn. Do not cock the packing gland. (This could cause binding or heating of the shaft).

E-Z 400 DIESEL MELTER - DOUBLE PUMPER

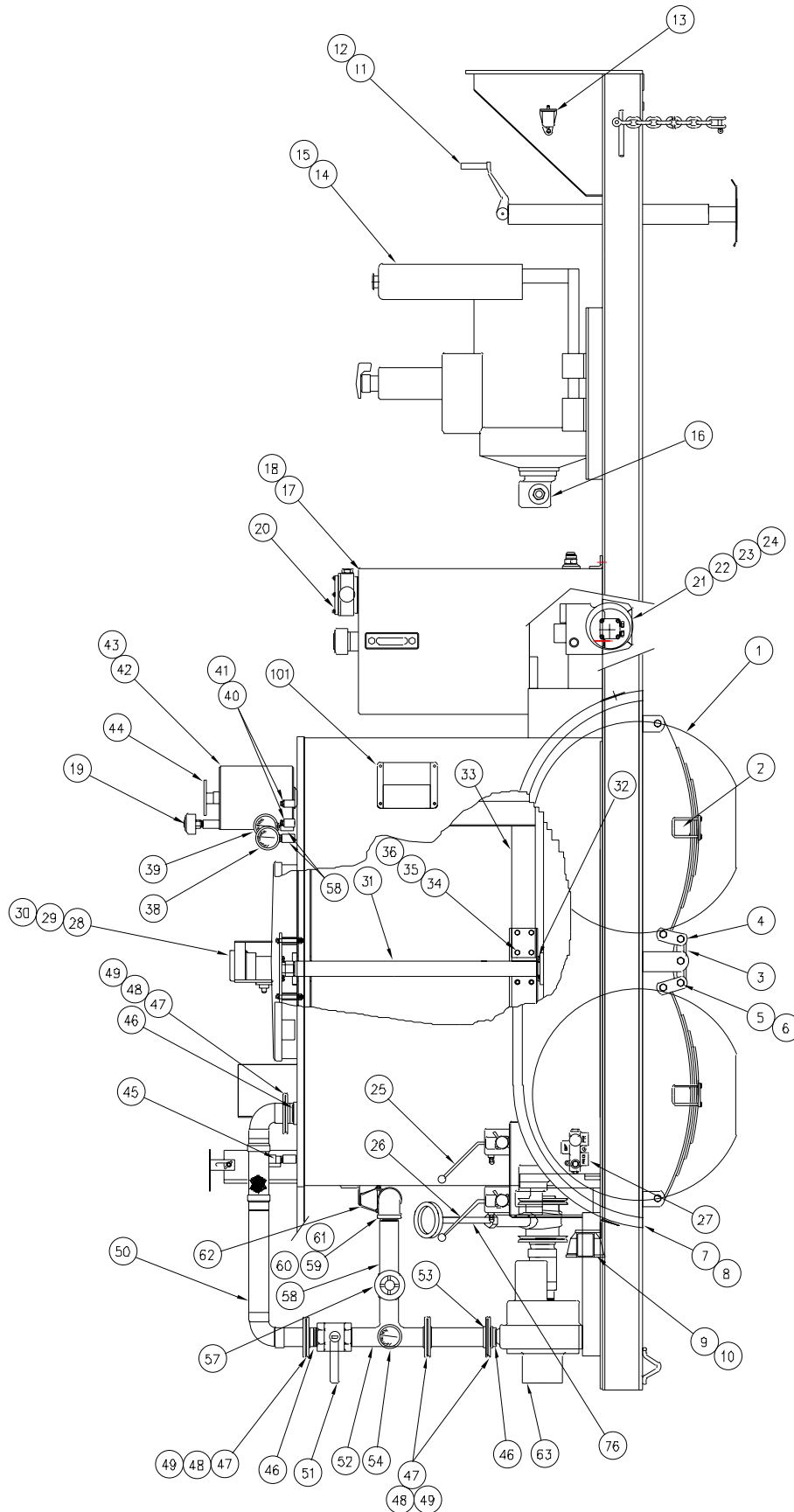

E-Z 400 DIESEL MELTER - DOUBLE PUMPER

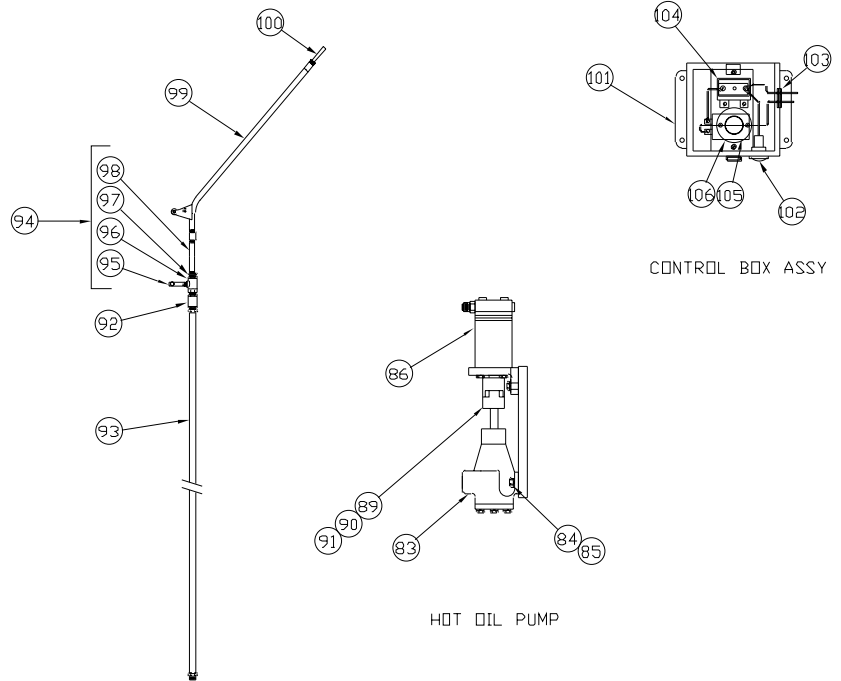

MATERIAL HOSE AND WAND ASSY

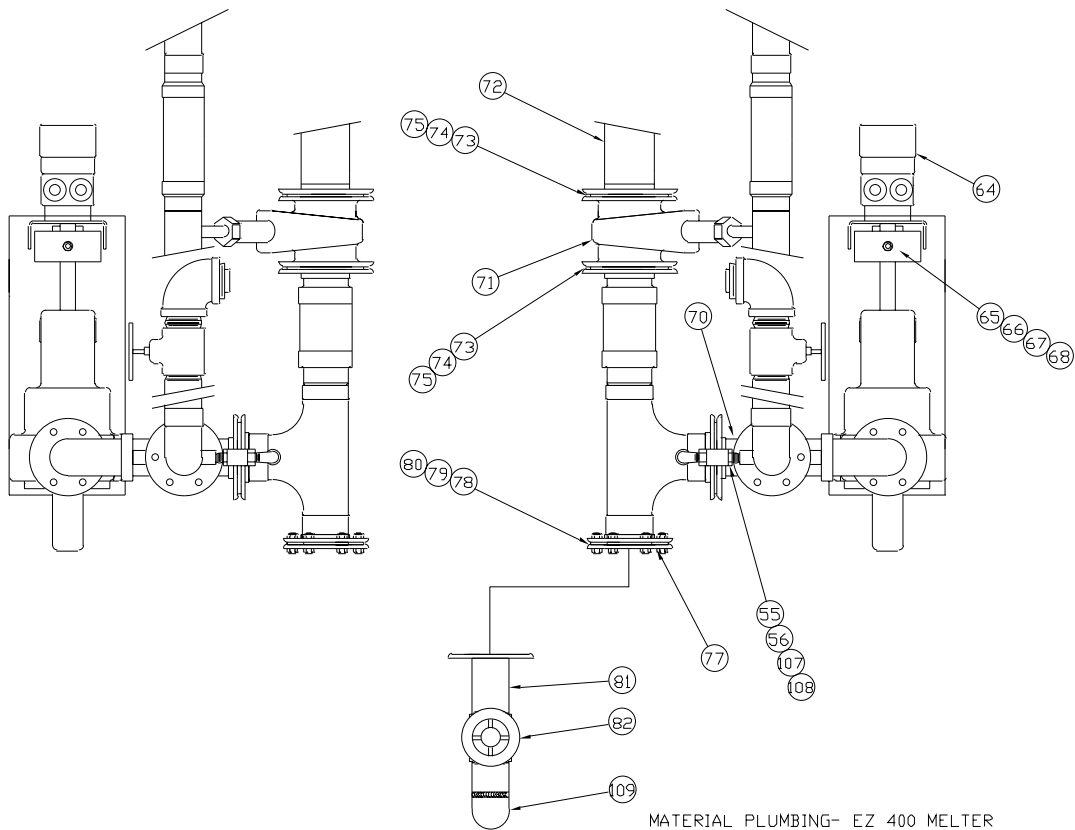

MATERIAL PLUMBING- EZ 400 MELTER

PARTS LIST FOR E-Z 400 DIESEL MELTER - DOUBLE PUMPER

NUMBER	PART NUMBER	QTY	DESCRIPTION
1	42515	4	TIRE AND RIM ASSEMBLY
2	42516	2	AXLE ASSEMBLY WITH SPRINGS
3	23088	2	ROCKER ARM
4	23075	8	SHACKLE TIE PLATE
5	23100	14	SHACKLE BOLT B2
6	23105	14	SHACKLE NUT N3
7	42718	1	FENDER ASSEMBLY
8	42718	1	FENDER ASSEMBLY
9	24022	1	TAIL LIGHT - RIGHT SIDE
10	24023	1	TAIL LIGHT - LEFT SIDE
11	23097	1	TONGUE JACK SIDE MOUNT
12	23096	1	JACK SWIVEL BUSHING
13	23117	1	BREAKAWAY SWITCH UNIT
14	43079	1	37 HP ISUZU ENGINE
15	29399	4	ISOMOUNT 3/8-16 THREAD INSERT
16	42664	1	P315B DOUBLE HYDRAULIC PUMP
17	43591	1	32 GAL DIESEL TANK ASSEMBLY
18	43590	1	32 GAL HYDRAULIC TANK ASSEMBLY
19	26025	1	AIR BREATHER & ELEMENT 1/2"L R-A
20	44805	1	FILTER ELEMENT (REPLACEMENT)
21	41891	1	ADC 14 VOLT BURNER
22	42559	1	BURNER NOZZLE
23	41890	1	14 V BLOWER MOTOR (SERVICE)
24	41888	1	FUEL SOLENOID (SERVICE)
25	41093	1	AGITATOR CONTROL VALVE

PARTS LIST FOR E-Z 400 DIESEL MELTER - DOUBLE PUMPER

NUMBER	PART NUMBER	QTY	DESCRIPTION
26	41092	2	MATERIAL PUMP CONTROL VALVE
27	41573	1	FLOW DIVIDER PRIORITY
28	42573	1	MIXER MOTOR MOUNT
29	40030	4	PIPE SPACER (HYDRAULIC MOTOR)
30	42574	1	MIXER MOTOR
31	42780	1	AGITATOR SHAFT ASSEMBLY 400G
32	28682	1	1 5/8" FLAT WASHER
33	42545	2	PADDLE ASSEMBLY
34	28731	8	3/8" - 16 THREAD X 1" BOLT
35	28647	8	3/8" LOCK WASHER
36	28526	8	3/8" - 16 ESNA-TYPE LOCK-NUT
37			NOT USED
38	41243	1	24" TEMPERATURE GAUGE BTM MOUNT
39	40078	1	12" TEMPERATURE GAUGE BTM MOUNT
40	28177	2	3/8 PIPE COUPLING
41	25203	2	STUFFING BOX
42	43355	1	OVER-FLOW TANK ASSEMBLY
43	43763	1	AIR RELIEF ASSEMBLY
44	41199	1	DIPSTICK ASSEMBLY HO TANK
45	25057	1	9" TEMPERATURE GAUGE BOTTOM MOUNT
46	22030	3	FLANGED NIPPLE ASSEMBLY
47	29050	4	2" FLANGE GASKET - 6 HOLE
48	28731	24	3/8" - 16 THREAD X 1" BOLT
49	28538	24	3/8 LOCKNUT
50	41678	1	PIPE ASSEMBLY UPPER 200

PARTS LIST FOR E-Z 400 DIESEL MELTER - DOUBLE PUMPER

NUMBER	PART NUMBER	QTY	DESCRIPTION
51	41246	2	RECIRCULATION VALVE
52	42785	1	FLANGE TEE
53	42555	1	PIPE ASSEMBLY DOUBLE ELBOW
54	25050	1	TEMP GAUGE 2-1/2" BACK MOUNT
55	28237	2	3/8 X 90 DEGREE STREET ELBOW
56	28282	2	3/8" PIPE PLUG
57	29270	2	BRONZE GATE VALVE-2"
58	28110	1	2" X 8" PIPE NIPPLE
59	28213	2	PIPE ELBOW 2" 90 DEGREE
60	41291	1	CROSS FEED PIPE
61	28358	1	2 X 1 HEX HEAD REDUCING BUSHING
62	26078	1	2" CLEVIS HANGER (260)
63	41101	1	ROPER MATERIAL PUMP (JACKETED)
64	22027	2	HYDRAULIC MOTOR
65	26002	4	CHAIN COUPLING SPROCKET 1" BORE
66	26016	2	DUAL SPROCK CHAIN-16-LINK
67	26030	2	CONNECTING LINK
68	41140	2	CHAIN GUARD W/HOLE
69			NOT USED
70	42529	1	MATERIAL PUMP SUCTION
71	29292	1	FLANGED GATE VALVE-3"
72	41039	1	DRAIN PIPE EXT ASSEMBLY
73	29060	2	GASKET - 3" CIRC FLANGE 8 HOLE
74	28731	16	3/8"-16 THREAD X 1" BOLT
75	28538	16	3/8"-16 STOVER C-TOP NUT

PARTS LIST FOR E-Z 400 DIESEL MELTER - DOUBLE PUMPER

NUMBER	PART NUMBER	QTY	DESCRIPTION
76	41268	2	VALVE HANDLE EXTENSION
77	29161	1	2-1/2 BLIND FLANGE
78	41043	2	2.94" FLANGE GASKET
79	28731	12	3/8"-16 THREAD X 1" BOLT
80	28538	12	3/8"-16 STOVER C-TOP NUT
81	41929	1	2-1/2 FLANGE ADAPTER
82	29270	2	BRONZE GATE VALVE - 2"
83	41280	1	HOT OIL CIRCULATING PUMP
84	28714	2	1/4 - 20 X 3-1/2 BOLT
85	28646	2	5/16" LOCK WASHER
86	22302	1	HYDRAULIC MOTOR
87			NOT USED
88			NOT USED
89	41180	1	1/2 BORE COUPLING HALF
90	41695	1	COUPLING HALF 5/8" BORE
91	41182	1	SPIDER FOR 070 COUPLING
92	27048	2	SWIVEL-MALE/FEMALE
93	27009	2	20' SEALANT HOSE
94	41208	2	HANDLE ASSEMBLY W/VALVE
95	27080	2	HAND GUN VALVE HANDLE ASSEMBLY
96	29240	2	BRONZE BALL VALVE - 1"
97	28351	2	1 X 3/4 HEX HEAD PIPE BUSHING
98	28100	2	3/4" X 8" NIPPLE
99	41629	2	HAND WAND ASSEMBLY
100	27171	2	SEALING TIP ASSEMBLY

PARTS LIST FOR E-Z 400 DIESEL MELTER - DOUBLE PUMPER

NUMBER	PART NUMBER	QTY	DESCRIPTION
101	25286	1	DIESEL CONTROL BOX ASSEMBLY
102	24140	1	INDICATOR LIGHT
103	26075	1	RUBBER GROMMET GR 34-14
104	25240	1	MANUAL RESET TEMPERATURE
105	25276	1	ELECTRIC THERMOSTAT - 550 DEGREES
106	25220	1	TEMPERATURE INDICATOR DIAL
107	28002	1	CLOSE NIPPLE XH-BLK 3/8"
108	29202	1	BRONZE BALL VALVE - 3/8"
109	40125	1	SPOUT ASSEMBLY
PARTS NOT ILLUSTRATED			
	24002	1	BATTERY BOX COVER
	24054	1	BATTERY CABLE 20"
	31512	1	CIRCUIT BREAKER
	32602	1	20" CRESCENT BATTERY CABLE
	24076	1	HOUR METER

DIESEL BURNER

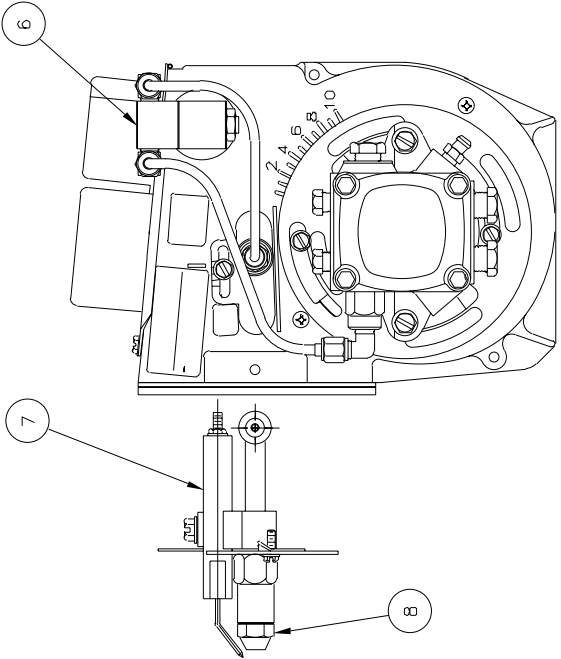
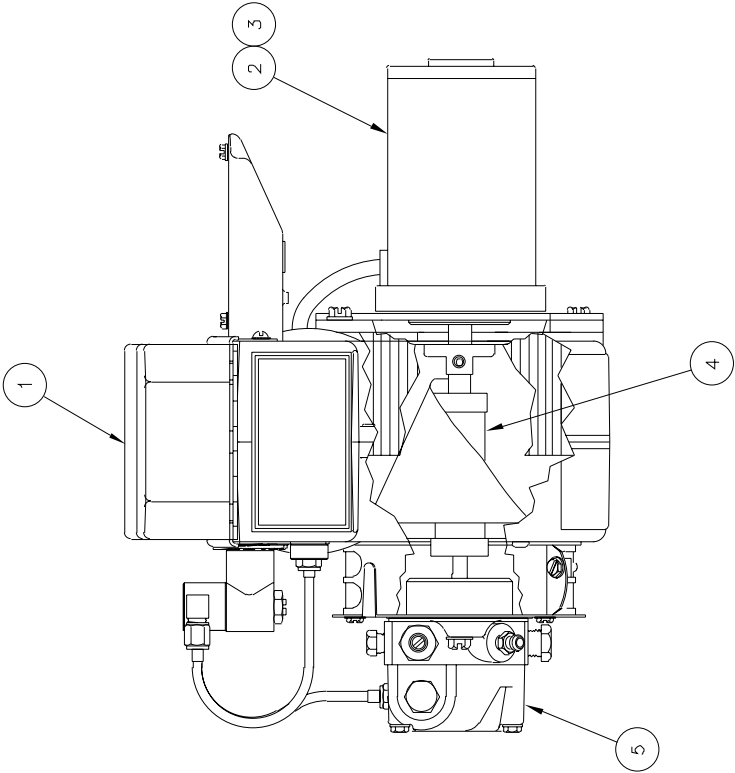

DIESEL BURNER

ITEM	PART NUMBER	QTY	DESCRIPTION
1	41949	-	IGNITION TRANSFORMER
2	41890	-	BLOWER MOTOR
3	41934	-	BRUSH KIT - MOTOR
4	41970	-	COUPLING - FUEL PUMP
5	41979	-	PUMP - FUEL
6	41888	-	SOLENOID - FUEL
7	41993	-	ELECTRODE
8	41883	-	NOZZLE
9	41870	-	CAD EYE
10	42335	-	DC CONTROLLER

HYDRAULIC PIPING DIAGRAM E-Z 400 DIESEL MELTER - DOUBLE PUMPER

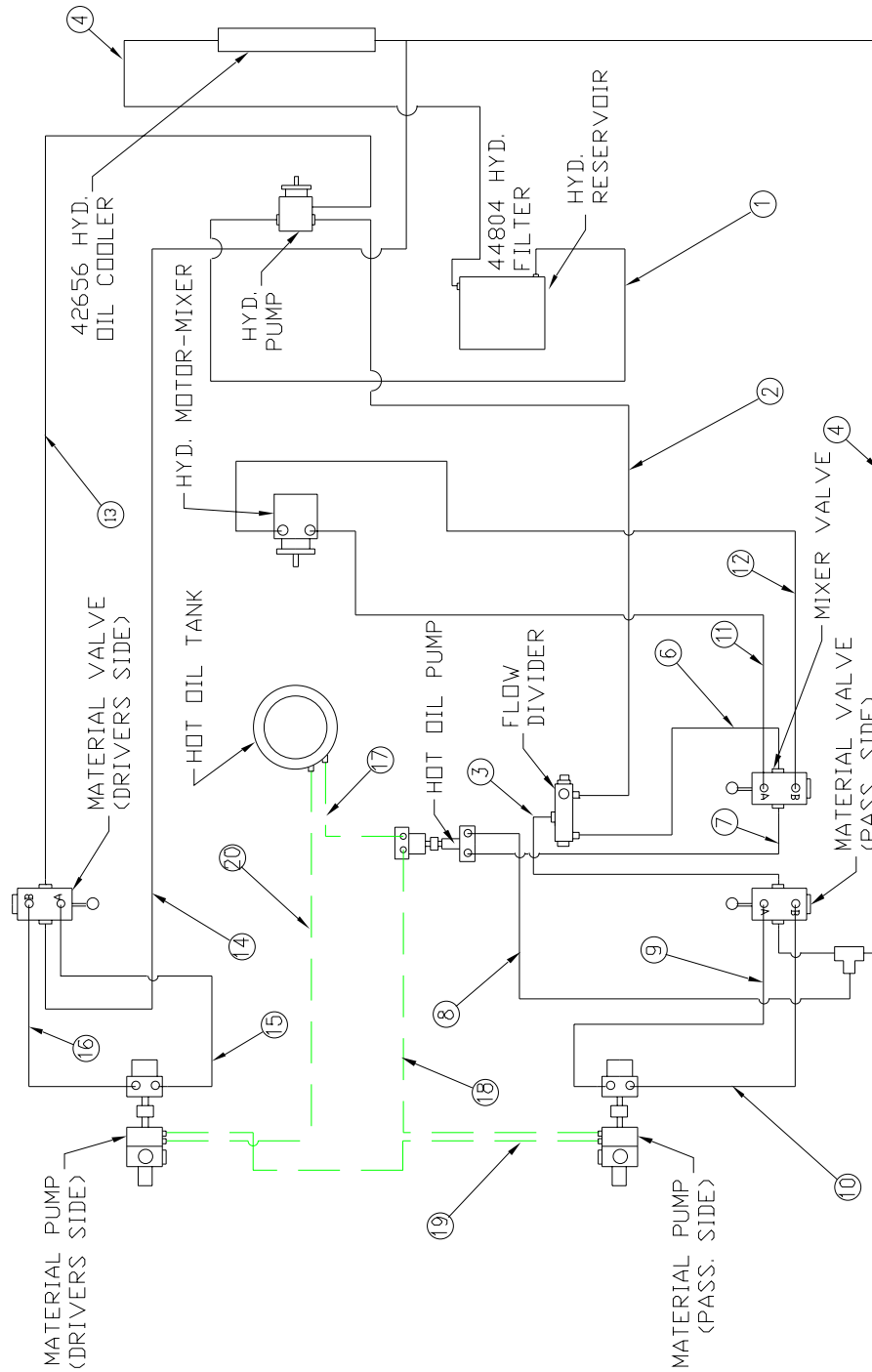

**HYDRAULIC PIPING SCHEMATIC
400 DOUBLE PUMPER**

— HYDRAULIC LINES
- - - HOT OIL LINES

HYDRAULIC PIPING - E-Z POUR 400 DIESEL MELTER DOUBLE PUMPER

1. HYDRAULIC RESERVOIR TO HYDRAULIC PUMP (SUCTION)		
1	29930	STRAIGHT ADAPTOR
1	C20-20FJ-20FJ-28	HYDRAULIC HOSE ASSEMBLY 1-1/4 X 28" LONG
1	29888	STRAIGHT ADAPTOR - "O" RING
2. HYDRAULIC PUMP PRESSURE TO FLOW DIVIDER VALVE ("IN" PORT)		
1	29862	90 DEGREE ELBOW ADAPTOR - "O" RING
1	AX8-10FJ-10FJ-48	HYDRAULIC HOSE ASSEMBLY 1/2 X 48" LONG
1	29805	BULKHEAD CONNECTOR
1	29807	LOCKNUT
1	42519	TUBE ASSEMBLY
1	29805	BULKHEAD CONNECTOR
1	29807	LOCKNUT
1	29815	PIPE SWIVEL CONNECTOR
1	28348	3/4 X 1/2 REDUCING BUSHING
3. FLOW DIVIDER VALVE ("PB" PORT) TO MATERIAL VALVE ("IN" PORT)		
1	28348	3/4 X 1/2 REDUCING BUSHING
1	29876	ELBOW ADAPTOR
1	AX6-6FJ-6FJ-18	HYDRAULIC HOSE ASSEMBLY 3/8 X 18" LONG
4. MATERIAL VALVE ("OUT" PORT) TO HYDRAULIC FILTER (RETURN)		
1	29813	90 DEGREE ELBOW ADAPTOR
1	AX8-10FJ-10FJ-19	HYDRAULIC HOSE ASSEMBLY 1/2 X 19" LONG
1	29811	SWIVEL RUN TEE
1	29805	BULKHEAD CONNECTOR
1	29807	BULKHEAD LOCKNUT
1	42519	TUBE ASSEMBLY
1	29805	BULKHEAD CONNECTOR
1	29807	LOCKNUT
1	AX8-10FJ-12FJ9-93	HYDRAULIC HOSE ASSEMBLY 1/2 X 93" LONG
1	29900	3/4" O-RING RUN TEE
1	-	HYDRAULIC OIL COOLER
1	29916	3/4" TUBE ELBOW
1	AX12-12FJ-12FJ9-71	HOSE ASSEMBLY 3/4" X 71" LONG
1	29816	STRAIGHT ADAPTOR
5. HYDRAULIC FILTER ("OUT" PORT) TO HYDRAULIC RESERVOIR		
1	43590	HYDRAULIC OIL TANK

HYDRAULIC PIPING - E-Z POUR 400 DIESEL MELTER DOUBLE PUMPER

6. FLOW DIVIDER VALVE ("REG" PORT) TO MIXER VALVE ("IN" PORT)		
1	28347	3/4 x 3/8 REDUCING BUSHING
1	29872	90 DEGREE ELBOW ADAPTOR
1	AX6-6FJ-6FJ-18	HYDRAULIC HOSE ASSEMBLY 3/8 X 18" LONG
7. MIXER VALVE ("OUT" PORT) TO HYDRAULIC MOTOR FOR HOT OIL PUMP (REAR PORT)		
1	AX6-6FJ-6FJ-18	HYDRAULIC HOSE ASSEMBLY 3/8 X 18" LONG
8. HYDRAULIC MOTOR FOR HOT OIL PUMP (FRONT PORT) TO TEE LINE LINE 4		
1	AX6-6FJ-6FJ-18	HYDRAULIC HOSE ASSEMBLY 3/8 X 18" LONG
1	29809	REDUCER 5/8 TO 3/8 TUBE
1	29810	TUBE NUT
9. MATERIAL VALVE ("A" PORT) TO HYDRAULIC MOTOR FOR MATERIAL PUMP ("BOTTOM" PORT)		
1	AX6-6FJ-6FJ-18	HYRAULIC HOSE ASSEMBLY 3/8 X 18" LONG
1	22029	STRAIGHT ADAPTOR
10. MATERIAL VALVE ("B" PORT) TO HYDRAULIC MOTOR FOR MATERIAL PUMP ("TOP" PORT)		
1	AX6-6FJ-6FJ-18	HYDRAULIC HOSE ASSEMBLY 3/8 X 18" LONG
1	22029	STRAIGHT ADAPTOR
11. MIXER VALVE ("A" PORT) TO HYDRAULIC MOTOR FOR MIXER (L.H. PORT)		
1	AX6-6FJ-6FJ-34	HOSE ASSEMBLY 3/8 X 34" LONG (400 ONLY)
1	29808	TUBE UNION
1	42550	TUBE ASSEMBLY
1	22029	STRAIGHT ADAPTOR
12. MIXER VALVE ("B" PORT) TO HYDRAULIC MOTOR FOR MIXER (CURB SIDE PORT)		
1	AX6-6FJ-6FJ-34	HOSE ASSEMBLY 3/8 X 34" LONG (400 ONLY)
1	29808	TUBE UNION
1	42551	TUBE ASSEMBLY
1	22029	STRAIGHT ADAPTOR
13. HYDRAULIC PUMP TO MATERIAL VALVE (DRIVER'S SIDE) "IN" PORT		
1	29812	5/8" TUBE X O RING
1	AX8-10FJ-10FJ-57	HOSE ASSEMBLY 1/2" X 57"
1	29805	BULKHEAD CONNECTOR
1	29807	LOCKNUT
1	42519	TUBE ASSEMBLY
1	29805	BULKHEAD CONNECTOR
1	29807	LOCKNUT
1	AX6-6FJ-6FJ-18	HOSE ASSEMBLY 1/2" X 18" LONG

HYDRAULIC PIPING - E-Z POUR 400 DIESEL MELTER DOUBLE PUMPER

14. MATERIAL VALVE "OUT" PORT TO HYDRAULIC OIL COOLER		
1	AX8-10FJ-10FJ-19	HOSE ASSEMBLY 1/2" X 19" LONG
1	29805	BULKHEAD CONNECTOR
1	29807	LOCKNUT
1	42519	TUBE ASSEMBLY
1	29805	BULKHEAD CONNECTOR
1	29807	LOCKNUT
1	AX8-10FJ-12FJ-70	HYDRAULIC HOSE 1/2" X 70" LONG
15. MATERIAL VALVE ("A" PORT) TO HYDRAULIC MOTOR FOR MATERIAL PUMP ("BOTTOM" PORT)		
1	29841	STRAIGHT ADAPTOR
1	AX6-6FJ-6FJ-24	HOSE ASSEMBLY 3/8" X 24" LONG
1	22029	STRAIGHT ADAPTOR
16. MATERIAL VALVE ("B" PORT) TO HYDRAULIC MOTOR FOR MATERIAL PUMP ("TOP" PORT)		
1	29841	STRAIGHT ADAPTOR
1	AX6-6FJ-6FH-24	HOSE ASSEMBLY 3/8" X 24" LONG
1	22029	STRAIGHT ADAPTOR
HOT OIL PIPING		
17. HOT OIL TANK (R.H. PORT) TO HOT OIL PUMP (FRONT PORT) - SUCTION		
1	28178	1/2 " PIPE COUPLER
1	29845	90 DEGREE ELBOW ADAPTOR
1	41404	HOSE ASSEMBLY S.S. COVER (1/2 X 22 1/2" LONG)
1	29844	STRAIGHT ADAPTOR
18. HOT OIL PUMP (REAR PORT) TO MATERIAL PUMP (TOP PORT)		
1	29844	STRAIGHT ADAPTOR
1	41404	HOSE ASSEMBLY S.S. COVER (1/2 X 22 1/2" LONG)
1	40316	STRAIGHT ADAPTOR
19. MATERIAL PUMP PASS. SIDE (BOTTOM PORT) MATERIAL PUMP DRIVER SIDE (BOTTOM PORT)		
1	40316	STRAIGHT ADAPTOR
1	41403	HOSE ASSEMBLY S.S. COVER (1/2 X 44 1/2" LONG)
1	40316	STRAIGHT ADAPTOR
20. MATERIAL PUMP (TOP PORT) TO HOT OIL TANK (L.H. PORT)		
1	40316	STRAIGHT ADAPTOR
1	41404	HOSE ASSEMBLY S.S. COVER (1/2 X 22 1/2" LONG)
1	29844	STRAIGHT ADAPTOR
1	28178	1/2" PIPE COUPLER

DIESEL PIPING DIAGRAM E-Z 400 DIESEL MELTER - DOUBLE PUMPER

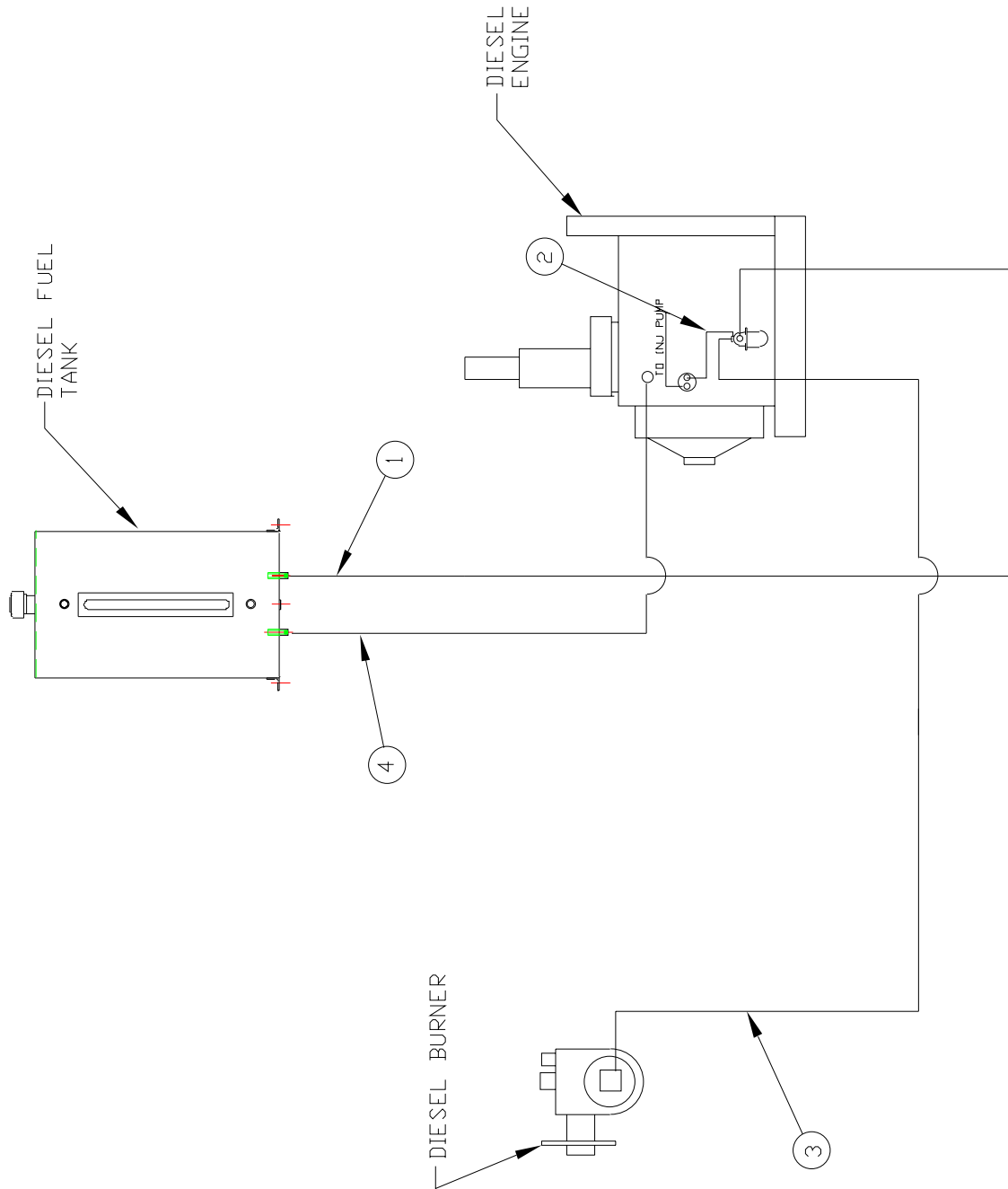

**DIESEL PIPING DIAGRAM
E-Z POUR 400 DIESEL MELTER - DOUBLE PUMPER**

1. DIESEL FUEL TANK TO FUEL FILTER		
1	26782	1/4 MALE PIPE X 5/16 JIC MALE 90
1	26767	PUSH ON FITTING
1	29590	FUEL HOSE 5/16 X 80" LONG
2	26080	GEAR CLAMP
2. DIESEL FUEL PUMP TO FUEL FILTER (SUPPLIED WITH ENGINE)		
3. FUEL FILTER TO DIESEL BURNER		
1	29591	FUEL HOSE 5/16 X 65" LONG
2	26080	GEAR CLAMP
1	26767	PUSH ON FITTING
1	26782	1/4 MALE PIPE X 5/16 JIC MALE 90
4. DIESEL ENGINE TO TANK (RETURN)		
1	29592	FUEL 3/16 X 80" LONG
2	26080	GEAR CLAMP
1	26790	1/8" STRAIGHT INV. FLARE PUSH-ON
1	29870	ELBOW ADAPTOR

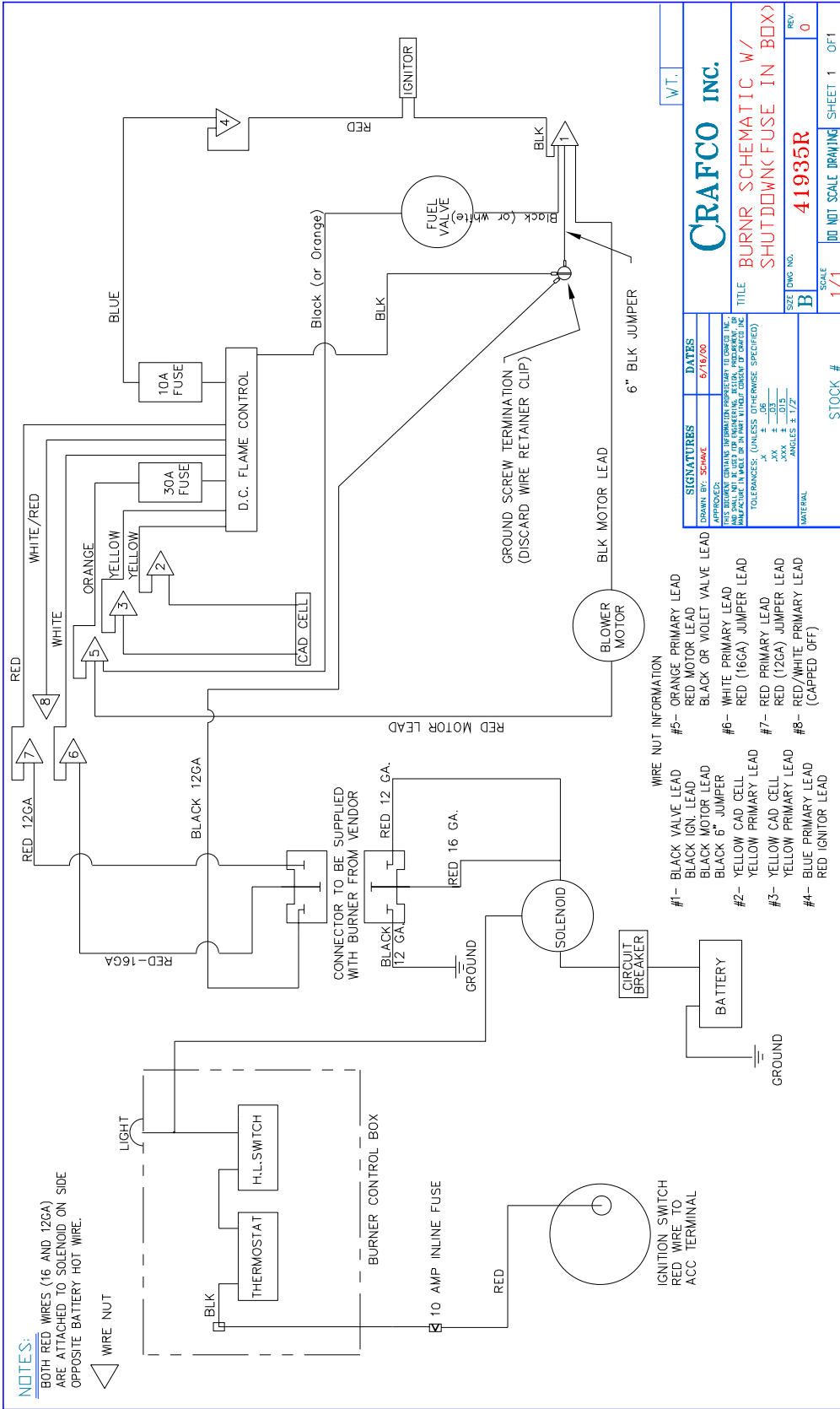

NOTES:

BOTH RED WIRES (16 AND 12GA) ARE ATTACHED TO SOLENOID ON SIDE OPPOSITE BATTERY HOT WIRE.

WIRE NUT

IGNITION SWITCH
RED WIRE TO
ACC TERMINAL

CIRCUIT
BREAKER

BATTERY

GROUND

- WIRE NUT INFORMATION**
- #1- BLACK VALVE LEAD
 - #2- BLACK IGN. LEAD
 - #3- BLACK MOTOR LEAD
 - #4- BLACK 6" JUMPER
 - #5- YELLOW CAD CELL
 - #6- YELLOW PRIMARY LEAD
 - #7- YELLOW CAD CELL
 - #8- YELLOW PRIMARY LEAD
 - #9- BLUE PRIMARY LEAD
 - #10- BLUE IGNITOR LEAD

- WIRE NUT INFORMATION**
- #5- ORANGE PRIMARY LEAD
 - #6- RED MOTOR LEAD
 - #7- BLACK OR VIOLET VALVE LEAD
 - #8- WHITE PRIMARY LEAD
 - #9- RED (16GA) JUMPER LEAD
 - #10- RED PRIMARY LEAD
 - #11- RED (12GA) JUMPER LEAD
 - #12- RED/WHITE PRIMARY LEAD (CAPPED OFF)

SIGNATURES		DATES	
DRAWN BY: SCHAKE		5/16/00	
<small>APPROVED: THIS DRAWING IS THE PROPERTY OF CRAFCO INC. IT IS TO BE USED ONLY FOR THE PROJECT AND MANUFACTURE IN WHICH IT WAS ORIGINALLY DESIGNED. IT SHALL NOT BE USED FOR REPAIRS, REVISIONS, MODIFICATIONS, OR REWORKS WITHOUT THE WRITTEN PERMISSION OF CRAFCO INC. TOLERANCES: (UNLESS OTHERWISE SPECIFIED)</small>			
TITLE		SCALE	
BURNR SCHEMATIC W/ SHUTDOWN FUSE IN BOX		1/1	
SIZE (DWG NO.)		JOB NOT SCALE DRAWING	
B		SHEET 1 OF 1	
MATERIAL		STOCK #	
41935R			
REV		REV	
0		0	

CRAFCO INC.

W.T.

**Pioneering Leadership and
Innovation in Quality
Pavement Maintenance
Materials.**



**235 South Hibbert • Mesa, Arizona 85210
480-655-8333 • Watts 1-800-528-8242
Fax 480-655-1712**

© Copyright 2001 by Crafcro, Inc.