



PATCHER II

For 2016 & Newer Patcher II's
Parts Manual - 57870
Revision G

Fill in the appropriate fields that apply to this machine.

Machine S/N: _____

1st Hose S/N: _____

2nd Hose S/N: _____

1st Pump S/N: _____

2nd Pump S/N: _____

Engine S/N: _____

Compressor S/N: _____

Gear Box S/N (Patcher): _____

Blower S/N (Magnum): _____



Patcher II Part Manual

Revisions

Revision	Description	Date
A	Updated engine power specs	6/14/16
B	Corrected Burner Baffle and Diffuser P/N's on Table 9-11, Added section 9.16 H.C. Pump and Motor Assembly	8/23/16
C	Updated warranty; added EAC and CE logos to page 2-3; Copyright date; added overnight heater extension cord info Table 5-6; Added Section 5.14; Added Section 6.23; Fig 9.11 and Table 9-10 Updated; updated Fig. 5.3	2/19/18
D	Removed Hot Tool Box PN 32310 and replaced with Hot Tool Box PN 57450N and Hot Tool Box Burner Assy 57485N . Updated all related figures and tables to reflect the change. Updated warranty start to invoice date	7/1/2018
E	Table 9-3, Gear box p/n fixed, Table 9-21 Spare tire p/n fixed.	8/7/18
F	Updated Prop. 65 information. Added a warning for overnight heater use. Added warnings and figure to section 5.14. Added parts 7 through 15 in Section 9.4.	1/4/19
G	Added 44786 Extended Burner Flame Retainer for Main burner to help operation in moist climates in Section 9.9, Fixed P/N error 57475N in Table 9-3.	3/20/19

Machine Views

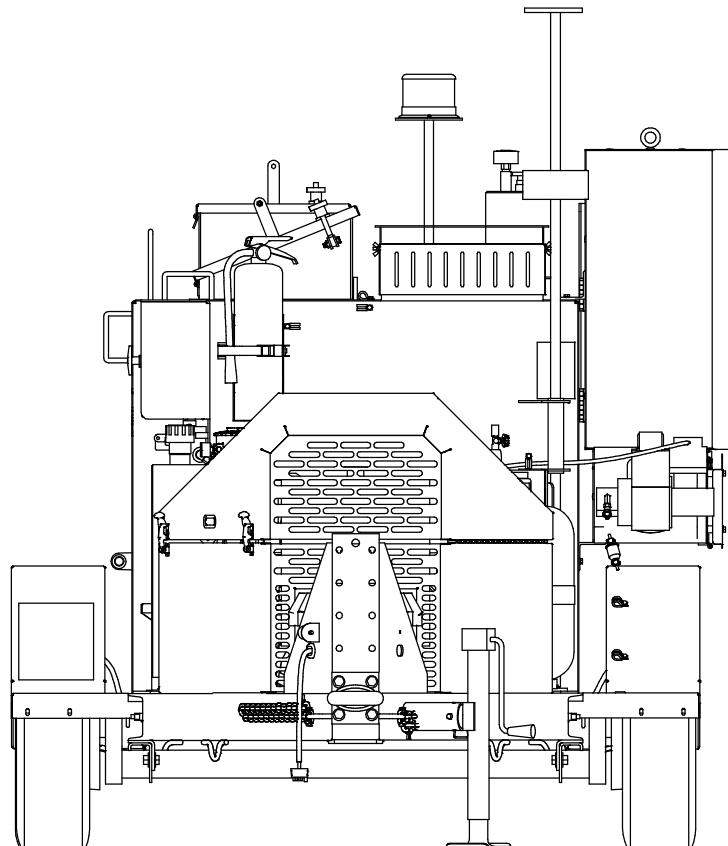
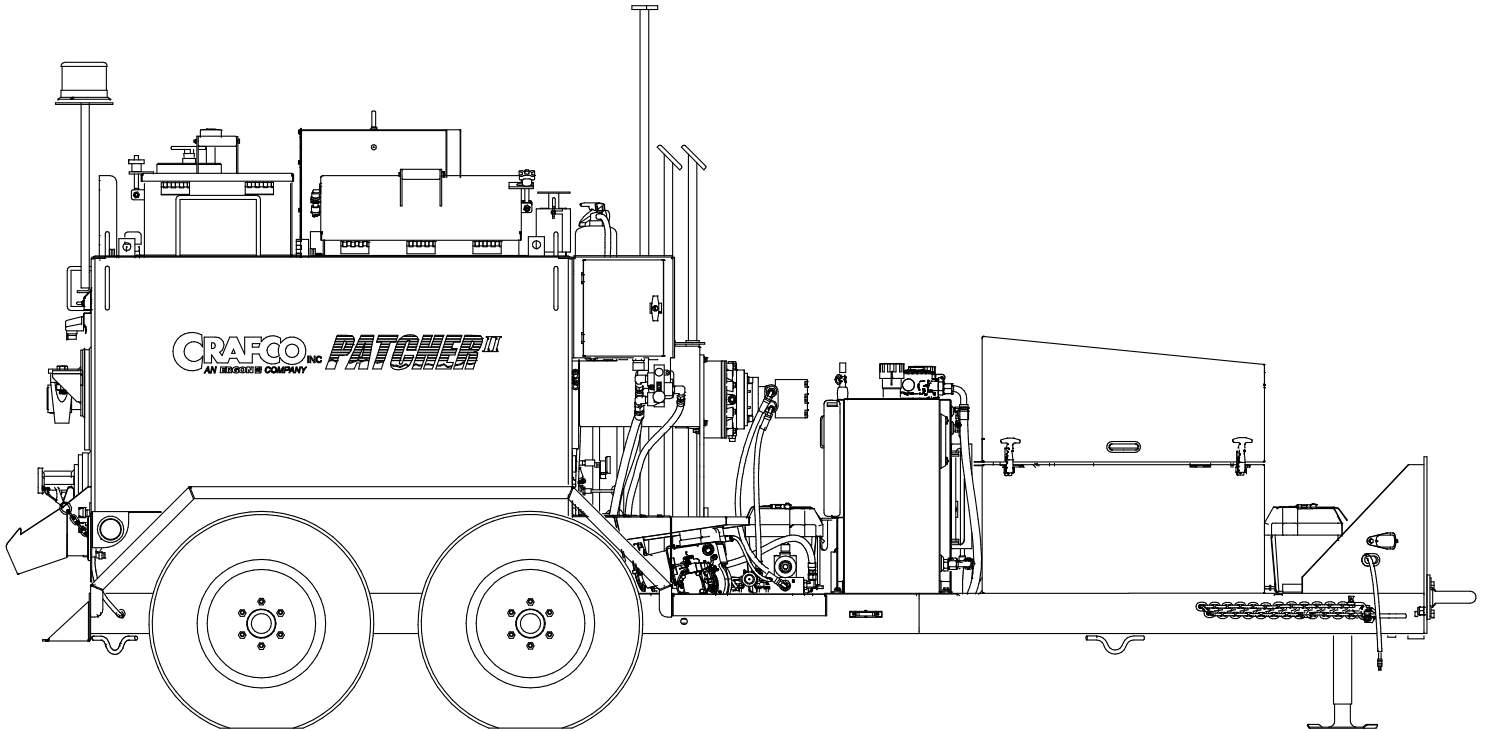

Machine Views

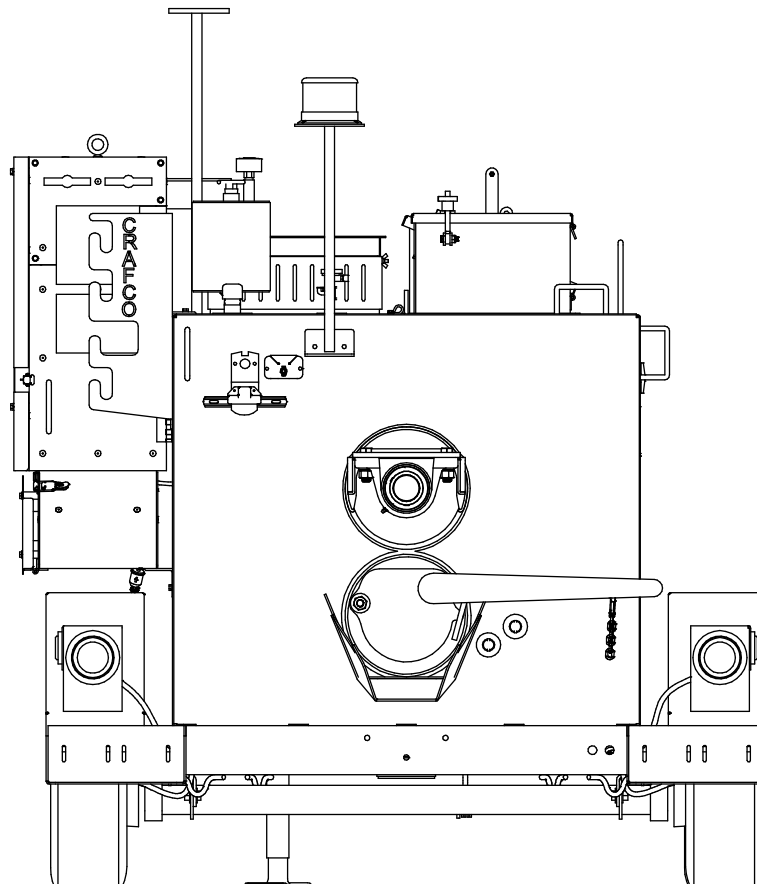
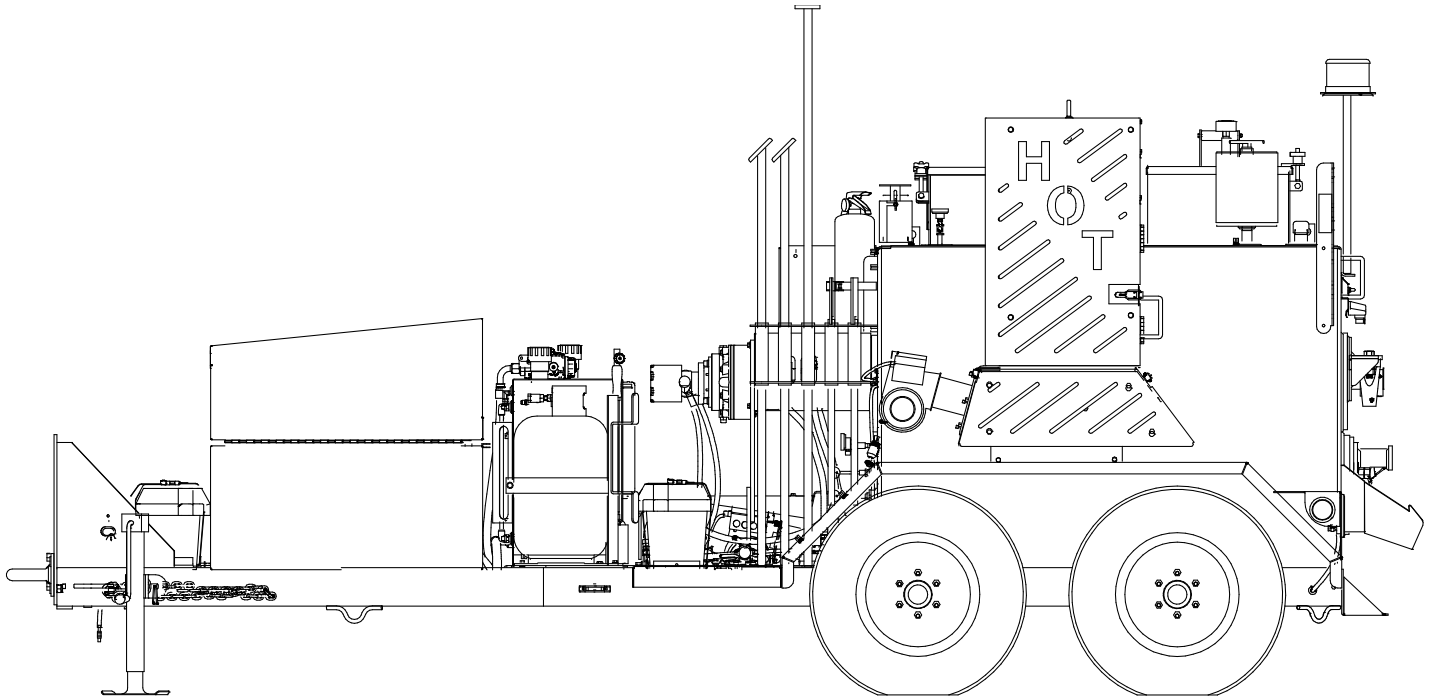

Table of Contents

Contents

1.0 About This Manual.....	1-1
1.1 How to use this Manual	1-1
2.0 Safety Precautions	2-1
2.1 General Safety.....	2-1
2.2 Personal Safety	2-1
2.3 Equipment or Operational Safety.....	2-1
2.4 California Proposition 65.....	2-2
2.4.1 All Crafcoc, Inc. Equipment	2-2
2.4.2 All Crafcoc, Inc. Equipment using a Diesel Engine	2-2
2.5 Safety Symbols and Notices	2-3
3.0 Limited Warranty	3-1
3.1 Warranty Claim Instructions.....	3-2
4.0 Machine Specifications	4-1
5.0 Operating Instructions.....	5-1
5.1 Introduction.....	5-1
5.2 Preparing the Machine for Start Up.....	5-1
5.3 Starting the Burner.....	5-5
5.4 Altitude Compensation System.....	5-7
5.5 Loading Material into Material Tank.....	5-7
5.6 Dispensing the Material	5-9
5.7 Shutting Down and Cleaning Out the Machine.....	5-10
5.8 Storing the Machine.....	5-10
5.9 Overnight Heaters	5-11
5.10 Hot Applied Patching Material Placement	5-12
5.11 Application Steps.....	5-13
5.12 Material Tank Depth to Capacity Chart	5-15
5.13 Removing Optional Heated Chute	5-16
5.14 Mounting a Skid Machine.....	5-18
6.0 Maintenance Instructions.....	6-1
6.1 Engine	6-1
6.2 Hydraulic System.....	6-1
6.3 Heat Transfer Oil	6-1
6.4 Mixer Packing Gland Seals.....	6-1

Table of Contents

6.5 Mixer Shaft Bearings.....	6-1
6.6 Material Sensor Tube.....	6-1
6.7 Lug Nuts	6-1
6.8 Wheel Bearing	6-2
6.9 Brakes	6-2
6.10 Tongue Jack	6-2
6.11 Water Separator.....	6-2
6.12 Temperature Control Calibration	6-2
6.13 Maintenance Chart.....	6-3
6.14 Service Instructions.....	6-4
6.15 Recommended Fluids and Lubricants	6-4
6.16 General Maintenance Parts	6-5
6.17 Recommended Spare Parts.....	6-5
6.18 Applicable Brands of Heat Transfer Oil	6-6
6.19 Typical Heat Transfer Oil Specifications.....	6-6
6.20 Adjusting the Discharge Gate	6-7
6.21 Adjusting and Replacing Mixer Shaft Packing.....	6-8
6.22 Cleaning Material Tank and Sensor Area.....	6-9
6.23 Cleaning the Melter	6-9
7.0 How to Use a Multimeter.....	7-1
7.1 Checking DC Voltage with a Multimeter	7-1
7.2 Checking AC Voltage with Multimeter	7-1
7.3 Checking Resistance (Ohms)	7-1
7.3.1 How to Check Wire Continuity	7-1
7.3.2 How to Check RTD Sensor	7-1
7.4 Checking Amperage	7-2
8.0 Troubleshooting	8-1
8.1 Burner Troubleshooting	8-1
8.1.1 Symptom: Burner will Not Ignite.....	8-1
8.2 Electrical Schematic.....	8-7
8.3 Testing the DC Controller.....	8-8
8.4 Burner Troubleshooting	8-8
8.5 Ignition Coil Troubleshooting.....	8-9
8.6 Bleeding the Diesel Burner	8-9

Table of Contents

8.7 Smoke Coming Out of the Exhaust Stack	8-10
8.8 Burner Electrode Adjustment	8-11
8.9 Burner Air Settings.....	8-11
8.10 Material is Heating Slowly	8-12
8.11 Mixer Troubleshooting	8-12
8.11.1 Symptom: Mixer Does Not Rotate.....	8-12
8.12 Mixer Hydraulic Troubleshooting.....	8-16
8.13 Hydraulic Schematic	8-18
8.14 RTD Sensor Ohms vs. Temperature.....	8-19
9.0 About the Illustrated Parts List	9-1
9.1 Ordering Crafcoc Parts	9-1
9.2 Patcher II Parts List	9-2
9.3 Fuel and Hydraulic Tanks Parts List	9-8
9.4 Engine Parts List	9-10
9.5 Hydraulic Schematic and Parts List	9-12
9.6 Hydraulic Valve Parts List	9-16
9.7 Safety Chain Parts List	9-17
9.8 Diesel Burner Fuel Line Schematic.....	9-18
9.9 Main Diesel Burner Parts List	9-20
9.10 Tool Box Diesel Burner Parts List	9-21
9.11 Control Box Parts List	9-22
9.12 Electrical Schematic Parts List.....	9-24
9.13 Optional Material Chute Parts List (P/N 56825)	9-26
9.14 Hydraulic Schematic for Optional Heated Chute	9-28
9.15 Optional Heated Chute Parts List (P/N 57783).....	9-32
9.16 Heated Chute Pump and Motor Assembly (P/N 41696)	9-36
9.17 Patcher II Options	9-38
10.0 Tools and Accessories.....	10-1

List of Figures

Figure 5-1 Hydraulic and Diesel Fill Caps	5-2
Figure 5-2 Hydraulic Fluid Level and Temp Gauge	5-2
Figure 5-3 Heat Transfer Oil Dipstick	5-3
Figure 5-4 Discharge Gate	5-4
Figure 5-5 Mixer Control Switch	5-4
Figure 5-6 Mixer Bearings	5-5
Figure 5-7 Engine Control Area	5-6
Figure 5-8 Control Panel	5-6
Figure 5-9 Loading Material Using the Lid	5-8
Figure 5-10 Flow Control Valve	5-9
Figure 5-11 Material Tank Depth to Capacity Chart	5-15
Figure 6-1 Lug Bolt Tightening Sequence	6-1
Figure 6-2 Temperature Control Calibration	6-2
Figure 7-1 Standard Multimeter	7-2
Figure 7-2 Clamp-On Amp Meter/Multimeter	7-3
Figure 8-1 Electrical Schematic (PN 26582)	8-7
Figure 8-2 Diesel Burner Electrode Adjustment	8-11
Figure 8-3 Diesel Burner Air Settings	8-11
Figure 8-4 Checking Din Plug Voltage	8-15
Figure 8-5 Hydraulic Pressure Adjustment Location	8-17
Figure 8-6 Din Plug Layout	8-17
Figure 8-7 Hydraulic Schematic (P/N 26589)	8-18
Figure 9-1 Right Iso View	9-2
Figure 9-2 Left Iso View	9-4
Figure 9-3 Top Section View	9-6
Figure 9-4 Fuel and Hydraulic Tanks Section View	9-8
Figure 9-5 Engine	9-10
Figure 9-6 Hydraulic Schematic (P/N 26589)	9-12
Figure 9-7 Hydraulic Schematic (PN 26589) (continued)	9-14
Figure 9-8 Hydraulic Valve	9-16
Figure 9-9 Safety Chains	9-17
Figure 9-10 Burner Fuel Line Schematic (PN 26599)	9-18
Figure 9-11 Main Diesel Burner	9-20
Figure 9-12 Tool Box Diesel Burner	9-21
Figure 9-13 Control Box Parts List (P/N 57856)	9-22
Figure 9-14 Electrical Schematic Parts List (PN 26582)	9-24
Figure 9-15 Optional Material Chute (P/N 56825)	9-26
Figure 9-16 Hydraulic Schematic for Optional Heated Chute (P/N 26569)	9-28
Figure 9-17 Hydraulic Schematic for Optional Heated Chute (PN 26569) (continued)	9-30

List of Figures

Figure 9-18 Optional Heated Chute (P/N 57783)	9-32
Figure 9-19 Optional Heated Chute Parts List (continued).....	9-34
Figure 9-20 Heated Chute Pump and Motor Assembly (P/N 41696).....	9-36
Figure 9-21 Patcher II Options.....	9-38
Figure 9-22 Patcher II Options.....	9-40

List of Tables

Table 2-1 Safety Symbols and Notices	2-3
Table 2-2 Safety Symbols and Notices (continued).....	2-4
Table 4-1 Machine Specifications	4-1
Table 5-1 Preparing the Machine for Start Up.....	5-1
Table 5-2 Starting the Burner.....	5-5
Table 5-3 Loading Material into the Material Tank	5-7
Table 5-4 Dispensing the Material	5-9
Table 5-5 Shutting Down and Cleaning Out the Machine.....	5-10
Table 5-6 Overnight Heaters.....	5-11
Table 5-7 Application Steps	5-13
Table 5-8 Application Steps Continued.....	5-14
Table 5-9 Temporary Removal of Optional Heated Chute.....	5-16
Table 5-10 Complete Removal of Optional Heated Chute.....	5-17
Table 5-11 Mounting a Skid Machine.....	5-18
Table 6-1 Maintenance Chart	6-3
Table 6-2 Maintenance Chart (continued).....	6-4
Table 6-3 Service Instructions	6-4
Table 6-4 Recommended Fluids and Lubricants.....	6-4
Table 6-5 General Maintenance Parts	6-5
Table 6-6 Recommended Spare Parts.....	6-5
Table 6-7 Applicable Brand of Heat Transfer Oil.....	6-6
Table 6-8 Typical Heat Transfer Oil Specifications.....	6-6
Table 6-9 Adjusting the Discharge Gate	6-7
Table 6-10 Adjusting and Replacing Mixer Shaft Packing.....	6-8
Table 8-1 Burner Basic Visual Troubleshooting	8-1
Table 8-2 Burner Electrical Troubleshooting	8-2
Table 8-3 Testing the DC Controller	8-8
Table 8-4 Burner Troubleshooting	8-8
Table 8-5 Ignition Coil Troubleshooting.....	8-9
Table 8-6 Bleeding the Diesel Burner	8-9
Table 8-7 Smoke Coming Out of the Exhaust Stack.....	8-10
Table 8-8 Burner Air Settings.....	8-11
Table 8-9 Material is Heating Slowly.....	8-12
Table 8-10 Mixer Basic Visual Troubleshooting	8-12
Table 8-11 Mixer Basic Visual Troubleshooting (continued).....	8-13
Table 8-12 Mixer Electrical Troubleshooting	8-13
Table 8-13 Mixer Electrical Troubleshooting (continued).....	8-14
Table 8-14 Mixer Electrical Troubleshooting (continued).....	8-15
Table 8-15 Mixer Hydraulic Troubleshooting.....	8-16

List of Tables

Table 8-16 RTD Sensor Ohms vs. Temperature.....	8-19
Table 9-1 Right View Parts List.....	9-3
Table 9-2 Left View Parts List.....	9-5
Table 9-3 Top Section View Parts List.....	9-7
Table 9-4 Fuel and Hydraulic Tanks Parts List	9-8
Table 9-5 Engine Parts List	9-11
Table 9-6 Hydraulic Parts List.....	9-13
Table 9-7 Hydraulic Parts List (continued)	9-15
Table 9-8 Hydraulic Valve Parts List.....	9-16
Table 9-9 Safety Chains Parts List	9-17
Table 9-10 Main Diesel Burner Parts List	9-21
Table 9-11 Tool Box Diesel Burner.....	9-21
Table 9-12 Control Box Parts List.....	9-23
Table 9-13 Electrical Schematic Parts List.....	9-25
Table 9-14 Optional Material Chute	9-27
Table 9-15 Hydraulic Schematic for Optional Heated Chute Parts List	9-29
Table 9-16 Hydraulic Schematic for Optional Heated Chute Parts List (continued).....	9-31
Table 9-17 Optional Heated Chute Parts List.....	9-33
Table 9-18 Optional Heated Chute Parts List (continued).....	9-35
Table 9-19 Heated Chute Pump and Motor Assembly Parts List	9-37
Table 9-20 Options Parts List	9-39
Table 9-21 Options Parts List (continued).....	9-41

Chapter 1 Introduction

1.0 About This Manual

This manual is supplied with each new Crafcro Patcher II. The manual assists your machine operators in the proper use of the Patcher II and provides information about the machine's mechanical functions.

Your Crafcro Patcher II is specially made to give excellent service and save maintenance expense. However, as with all specially engineered equipment, you will get the best results at minimum cost if you:

- Operate your machine as instructed in this manual.
- Maintain your machine regularly as stated in this manual.

1.1 How to use this Manual

This manual is formatted to start each new chapter on the right page. There may be a blank page on the left page if the previous chapter ends on the right page.

If you are viewing this in a digital format (PDF) the following features are available:

1. The Table of Contents, List of Tables, and List of Figures are all hyperlinks, when left mouse clicked on section, table, or figure you will be sent to that page.
2. The blue highlighted text throughout the manual is a hyperlink, when left mouse clicked you will be sent to that page, table, or figure.
3. The panel to the left in the PDF is a bookmarks panel, if you left mouse click on any section/heading in the bookmarks panel you will be sent to that page.
4. There is an attachments icon (paper clip) to the left of the bookmarks, this is where you will find full size prints of the control box, electrical, and hydraulic schematics if available.

Chapter 2 Safety Precautions

2.0 Safety Precautions

For more in-depth safety information, please see Safety Manual (PN 26221) which comes with the machine. Or contact your nearest authorized Crafcro Distributor at crafcro.com/Distributors.

2.1 General Safety

- Crafcro, Inc. assumes no liability for an accident or injury incurred through improper use of the machine.
- Read this manual thoroughly before operating the machine.
- Obey all CAUTION and WARNING signs posted on the machine.
- Make sure an operator fully knows how to operate the machine before using the machine.

2.2 Personal Safety

- The high operating temperatures of this machine and the material it contains requires that protective clothing, gloves, hard-soled shoes, and safety glasses or a face shield be worn at all times by operators of the machine.
- Prevent water from going into any part of the machine. If there is indication of water in the heat transfer oil system, warm heating oil to 250-300°F for 2 to 3 hours.
- Bodily contact with hot material or heat transfer oil can cause severe burns.
- If the mixer is not stopped before adding solid material, hot material can get on an operator's body and cause severe burns.
- Keep hands, feet, and clothing away from all moving parts.

2.3 Equipment or Operational Safety

- Do not operate the machine in buildings or work areas that do not have sufficient airflow.
- Shut down the burner and the engine before refilling the fuel tank.
- Make sure the mixer stops before adding solid material to the material tank. Lift the lid, place the material on the lid and close the lid. The mixer should start automatically.
- Always keep a correctly maintained fire extinguisher near the machine and know how to use it.
- DO NOT heat transfer oil to a temperature of more than 525°F.
- DO NOT put too much heat transfer oil in the reservoir. The expansion of oil while it heats up can cause overflow. With the machine on level ground, check the oil each day before starting the burner. Add oil to the top mark on the dipstick if required (at 70°F). Use only recommended heat transfer oil. Change the oil after 500 hours of machine operation, or one year, whichever comes first.
- Follow the operating instructions for starting and shutting down the burner.
- Calibrate the temperature control knobs after each 50 hours of machine operation. Refer to [Figure 6.2 Temperature Control Calibration](#).
- Replace any hoses which show signs of wear, fraying or splitting.
- Make sure all fittings and joints are tight and do not leak each time the machine is used.
- Do not leave the machine unattended while the burner is lit.
- Tighten all bolts and screws every 100 hours of machine operation.

Chapter 2 Safety Precautions

2.4 California Proposition 65

The state of California currently maintains a list of chemicals that can cause cancer, birth defects or other reproductive harm. Your Crafcro, Inc. equipment comes with the following warnings:

2.4.1 All Crafcro, Inc. Equipment

 **WARNING:** Cancer and Reproductive Harm - www.P65Warnings.ca.gov
2647 1N

2.4.2 All Crafcro, Inc. Equipment using a Diesel Engine

 **WARNING:** Breathing diesel engine exhaust exposes you to chemicals known to the State of California to cause cancer and birth defects or other reproductive harm.

- Always start and operate the engine in a well-ventilated area.
- If in an enclosed area, vent the exhaust to the outside.
- Do not modify or tamper with the exhaust system.
- Do not idle the engine except as necessary.





For more information go to www.P65warnings.ca.gov/diesel.
26307

Chapter 2 Safety Precautions

2.5 Safety Symbols and Notices







Important safety symbols and notices are marked on the machine and in this manual. Failure to comply could result in equipment damage, operational malfunction, serious injury, or death. Please read and comply with all symbols and notices. The table below includes the most commonly used symbols and notices.

Table 2-1 Safety Symbols and Notices

Symbol	Item	Remarks
WARNING	Warning	Refers to possible bodily injury or death.
CAUTION	Caution	Refers to possible equipment damage or operational malfunction.
	Severe Burn Hazard	Hot material can cause severe burns.
	Protective Shoes	Wear hard-soled work shoes.
	Protective Gloves	Wear heat resistant gloves.
	Protective Face or Eye Wear	Wear face shield or safety glasses.
	Body Crush Hazard	Do not stand between trailer and hitch when hooking melter to truck.

Chapter 2 Safety Precautions

Table 2-2 Safety Symbols and Notices (continued)

Symbol	Item	Remark
	Crush Hazard	Keep feet and legs clear.
	Pinch Hazard	Keep hands and feet clear.
	Moving Machinery	Never reach into moving machinery.
	Exhaust Hazard	Avoid breathing engine exhaust.
	Noise Hazard	Ear protection is advisable.
	Read Manual	Read and understand operator and safety manuals before operating machine.



Chapter 3 Warranty Information

3.0 Limited Warranty

Crafco, Inc. (Manufacturer), or one of its affiliated distributors, will replace for the original purchaser free of charge any parts found upon examination by the Manufacturer, to be defective in material or workmanship. This warranty is for a period **two years** from the invoice date, but excludes engine or components, tires, and battery as these items are subject to warranties issued by their manufacturers.

Crafco, Inc. shall not be liable for parts that have been damaged by accident, alteration, abuse, improper lubrication/maintenance, normal wear, or other cause beyond our control.

The warranty provided herein extends only to the repair and/or replacement of those components on the equipment covered above and does not cover labor costs. The warranty does not extend to incidental or consequential damages incurred as a result of any defect covered by this warranty.

All transportation and labor costs incurred by the purchaser in submitting or repairing covered components must be borne by the purchaser. Crafco, Inc. specifically disavows any other representation, warranty, or liability related to the condition or use of the product.

CAUTION

Use of replacement parts other than genuine Crafco parts may impair the safety or reliability of your equipment and nullifies any warranty.

Chapter 3 Warranty Information

3.1 Warranty Claim Instructions

Crafco, Inc. warrants parts and machinery purchased through Crafco or one of its affiliated distributors for two years from the invoice date. Wear items are not covered under the Crafco, Inc. limited warranty. A wear item is defined as but not limited to: material pumps, sealing tips, tires, etc.

If parts fail to function within the two years of invoice date, a return authorization number (RA) must be obtained. If the part was purchased through Crafco, Inc., please contact Crafco returns department at [Returns@Crafco.com](mailto>Returns@Crafco.com) for an RA number or if purchased through a Crafco distributor please contact your distributor.

Note: if the part has a serial number associated with it, for example; a machine or electric hose or wand, this must be furnished when requesting the RA number. The customer will be emailed or faxed an RA form with all instructions to return the item to Crafco, Inc. See example. If the part is found to be within the two year warranty period and has not been abused or modified, a credit will be issued to the customer's account or credit card. The customer may request the part be replaced instead of a credit, if desired.

Note: All engine warranties are covered through the engine manufacturer. If you need information for a distributor in your area please contact us and we will direct you to the closest engine distributor.

All parts returned are tested and evaluated. If the part has been modified in any way without prior consent from a Crafco, Inc. representative, warranty is void.

Please follow the instructions stated below when calling in a Warranty Claim. Failure to follow these procedures may be cause to void the warranty.

Call your local Crafco Distributor. If you do not know who your local distributor is, call a Crafco Customer Service Representative, (Toll Free 1-800-528-8242) for name, location and telephone number.

On contacting the distributor, be prepared to identify the serial number, model number, engine number, engine manufacturer, and the date of purchase if available.

Should the cause of the malfunction be a defective part, the Distributor will advise you of the procedure to follow for a replacement.

The warranty is valid only for parts, which have been supplied or recommended by Crafco, Inc.

If you have any additional questions regarding warranty repairs and parts, please do not hesitate to call toll free 1-800-528-8242.

For Warranty:
Crafco, Inc.
25527 South Arizona Avenue, Chandler, AZ
85248
Phone: (480) 655-8333 or (800) 528-8242
Fax: (480) 655-1712

For all other inquires:
Crafco, Inc.
6165 West Detroit Street
Chandler, AZ 85226
Phone: (602) 276-0406 or (800) 528-8242
Fax: (480) 961-0513
CustomerService@crafco.com

Chapter 4 Machine Specifications

4.0 Machine Specifications

Table 4-1 Machine Specifications

Specification	PN 56700
Vat capacity	200 gallons
Heat transfer oil required	35 gallons at 70°F
Tank construction	Double boiler type
Tank opening size	1 material opening 16" x 24"
Bucket Opening Size	1 bucket opening 15.5" x 18"
Maximum heat input	370,000 BTUs
Burner and temperature control	Diesel-forced air thermostatic control
Engine Isuzu Diesel	Three cylinder Model 3CJ1 Tier 4 19 HP @ 3000 RPM
Drive Mechanism	All hydraulic with infinite forward and reverse speed control
Mixer	Horizontal shaft with 4 sweep paddles
Dry Weight	Approximately 4,900 lbs.
Shipping Weight	Approximately 5,300 lbs.
Diesel Tank Capacity	26 Gallons
Hydraulic Tank Capacity	12 Gallons
Axle Capacity	Dual 5,200 lbs.
Tires	ST225/75R15, Load Range D

Chapter 5 Operating Instructions

5.0 Operating Instructions

5.1 Introduction

The Crafcro Patcher II was developed to melt Crafcro TechCrete, Mastic One, Matrix 501 and PolyPatch products.

Note: DO NOT attempt to operate the machine without using these and all other instructions.

5.2 Preparing the Machine for Start Up

Table 5-1 Preparing the Machine for Start Up

Step	Action
1	Fill the engine fuel tank with diesel fuel. Note: Refer to the manufacturer's instruction manual for more specifications on fuel requirements.
2	Check the oil level in the engine crankcase. Refer to the manufacturer's instruction manual for the engine.
3	Check the hydraulic fluid level while at a temperature of 70°F. Add fluid if necessary. See Figure 5.2 Hydraulic Fluid Level and Temp Gauge .
4	With the machine on level surface, check the heat transfer oil level while at a temperature of 70°F. The oil should be at the full mark on the dipstick. DO NOT overfill or spillage may occur when the oil is heated and expands. See Figure 5.3 Heat Transfer Oil Dipstick
5	Make sure discharge gate is in the closed position. See Figure 5.4 Discharge Gate
6	Place the mixer control switch in the neutral position. See Figure 5.5 Mixer Control Switch
7	Make sure all toggle switches are turned "OFF" and all temperature control dials are set to their minimum settings.
8	Grease both front and rear mixer bearings weekly. See Figure 5.6 Mixer Bearings
9	Make sure the fuel valve on the water separator is set to "ON".
WARNING	
	<p>The safe operation of this machine is the operator's responsibility.</p> <p>Use extreme care when operating this machine; safety is the result of being careful and paying attention to details. Remember the diesel flame is approximately 2,200°F. Some exposed parts of the machine reach 500°F, the material 400°F, and the hydraulic fluid 200°F.</p> <p>Always put on protective clothing, gloves, hard-soled shoes, and safety glasses or a face shield. Be sure that all joints and fittings are tight and leak proof. Immediately replace any hose, which shows any signs of wear, fraying, or splitting. Tighten all bolts, nuts, and screws every 100 hours.</p>

Chapter 5 Operating Instructions

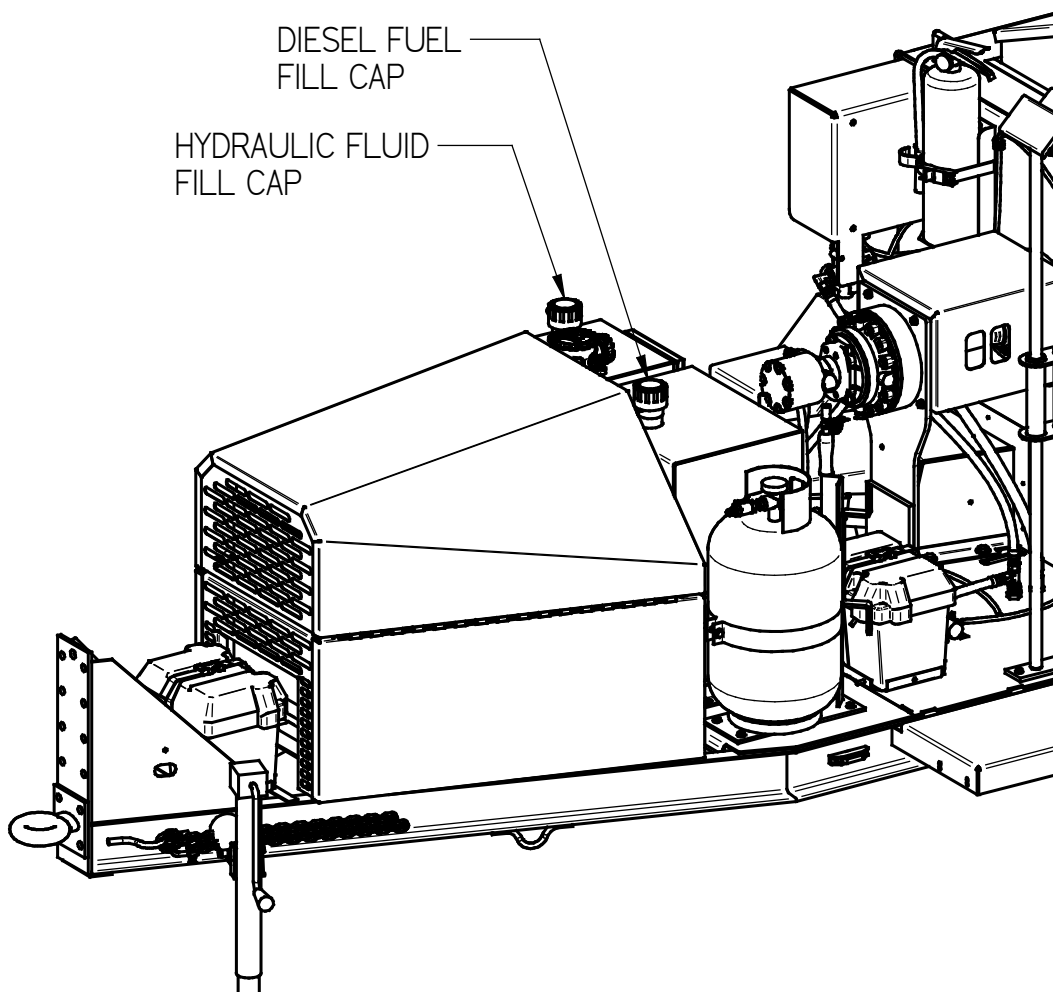

Figure 5-1 Hydraulic and Diesel Fill Caps

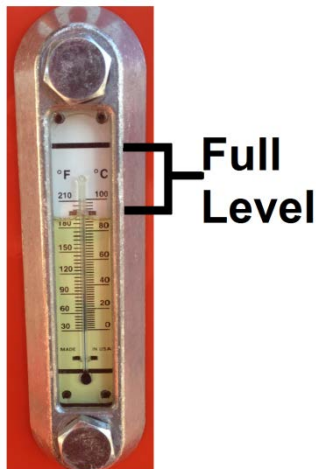

Figure 5-2 Hydraulic Fluid Level and Temp Gauge

Chapter 5 Operating Instructions

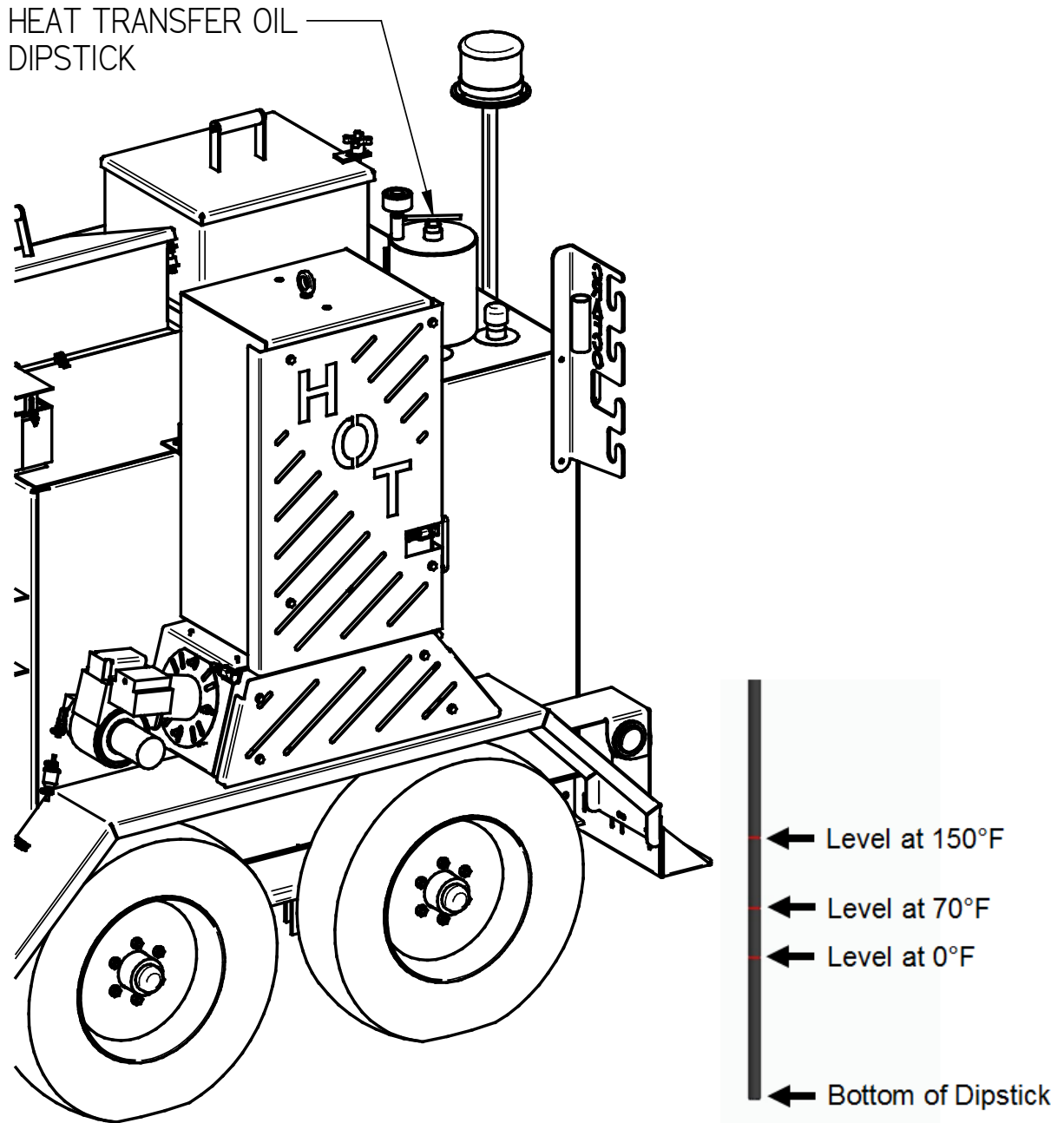

Figure 5-3 Heat Transfer Oil Dipstick

Chapter 5 Operating Instructions

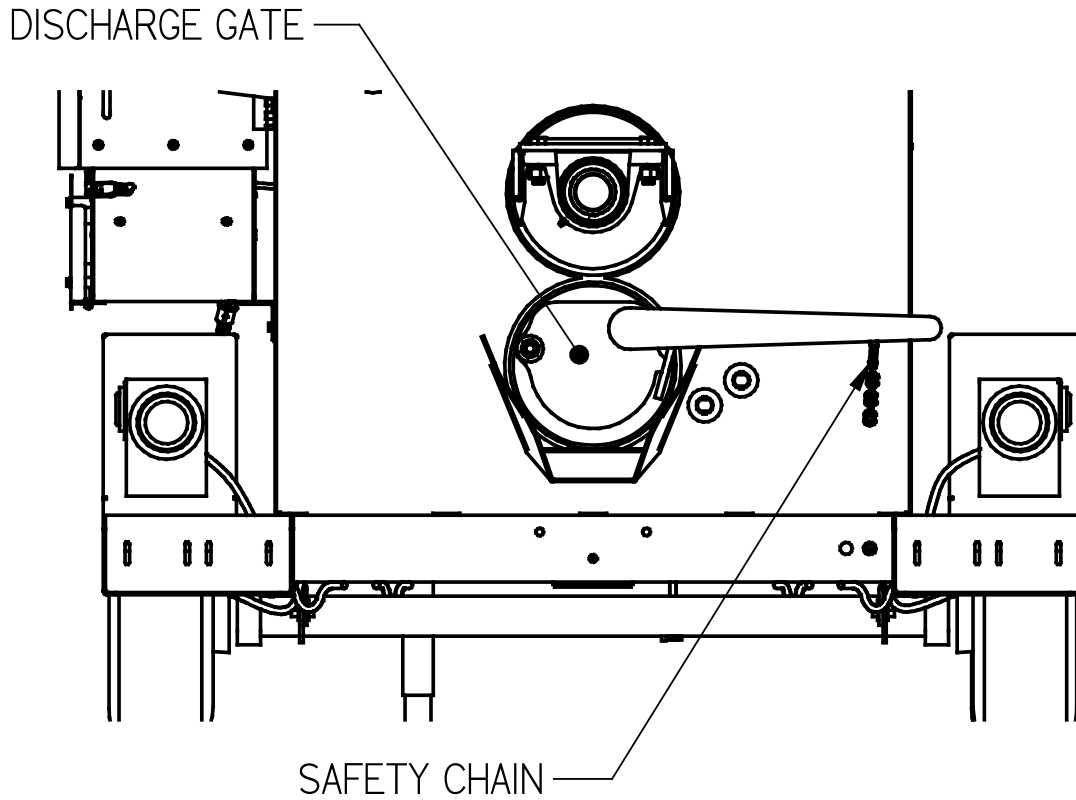

Figure 5-4 Discharge Gate



Figure 5-5 Mixer Control Switch

Chapter 5 Operating Instructions

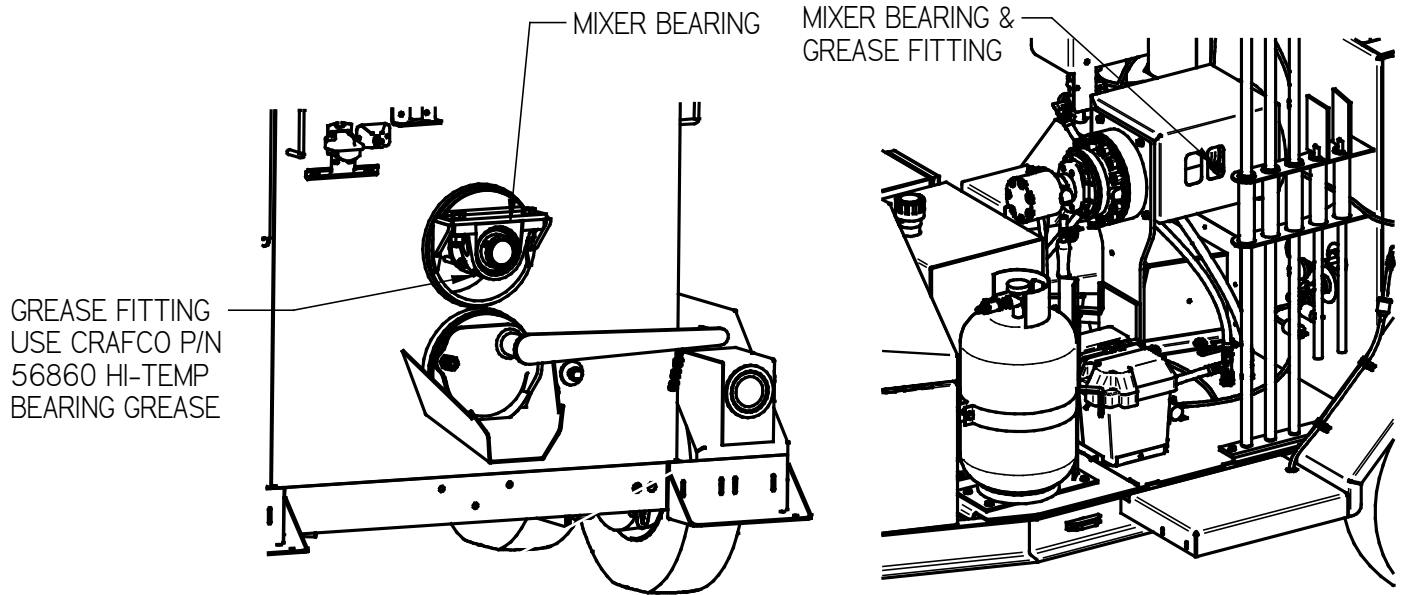

Figure 5-6 Mixer Bearings

5.3 Starting the Burner

Table 5-2 Starting the Burner

Step	Action
1	Fully open the exhaust stack cover.
2	Start the engine. Refer to the manufacturer's instructions for the engine. Insert the key into the control panel near the engine. If the engine is cold, turn the key to the preheater position. Let it warm up for 30 seconds or so. The warning lights should turn "ON". Turn the key to the second position, and the engine should start. Release the key once the engine is running. Leave at idle when heating up the heat transfer oil. When you are ready to agitate, then move the throttle knob to the desired speed. See Figure 5.7 Engine Control Area
3	Turn the "POWER" toggle switch in the control box to the "ON" position.
4	Set the heat transfer oil temperature at 525°F. See Figure 5.8 Control Panel
5	Set the material temperature to the manufacturer's recommended temperature.
	<p style="text-align: center;">CAUTION</p> <p>If the burner does not ignite the first time, turn the "POWER" toggle switch to the "OFF" position. Turn the toggle switch to "ON" again; the burner should ignite. If the burner still does not ignite, refer to Table 8-1 Burner Basic Visual Troubleshooting to determine the cause of the malfunction.</p> <p>Important: The solid material in the tank melts first around the walls and bottom of the tank. The material temperature sensor is located by the wall, therefore, it is possible that at the beginning of the melting process the indicated temperature reaches operating value, but the material closer to the center of the tank is still solid. This is normal.</p>
6	Allow the heat transfer oil to continue to heat.

Chapter 5 Operating Instructions

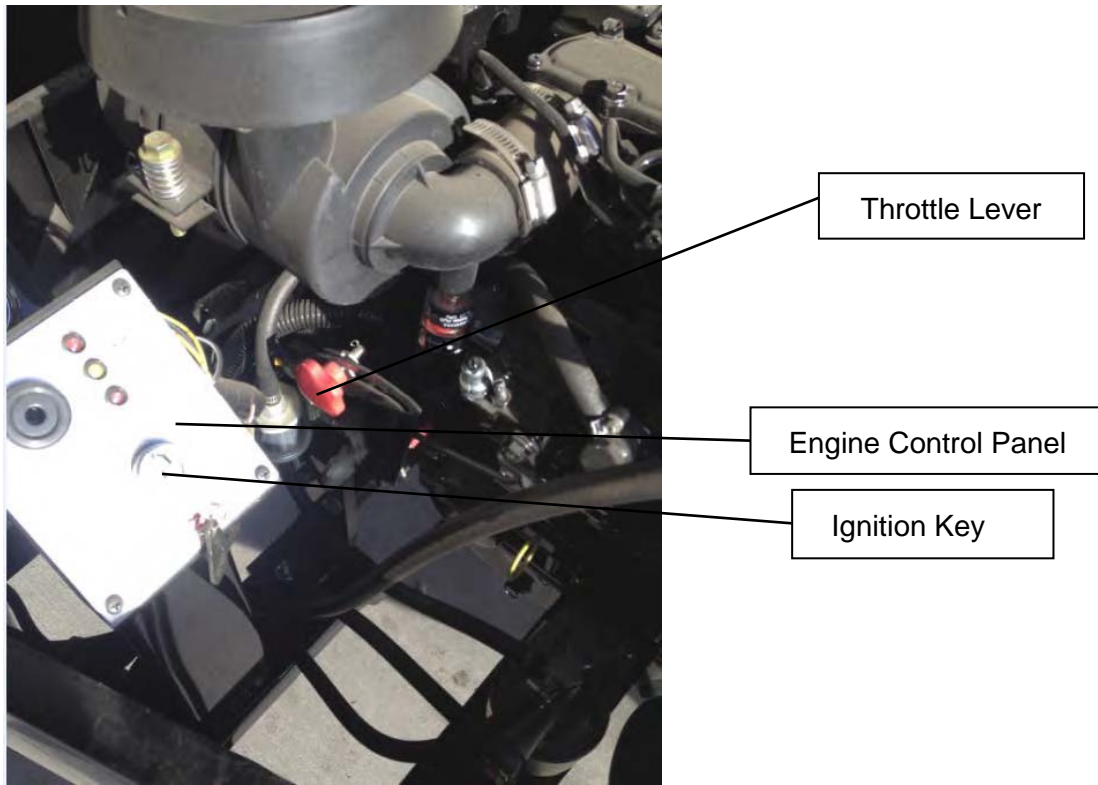

Figure 5-7 Engine Control Area

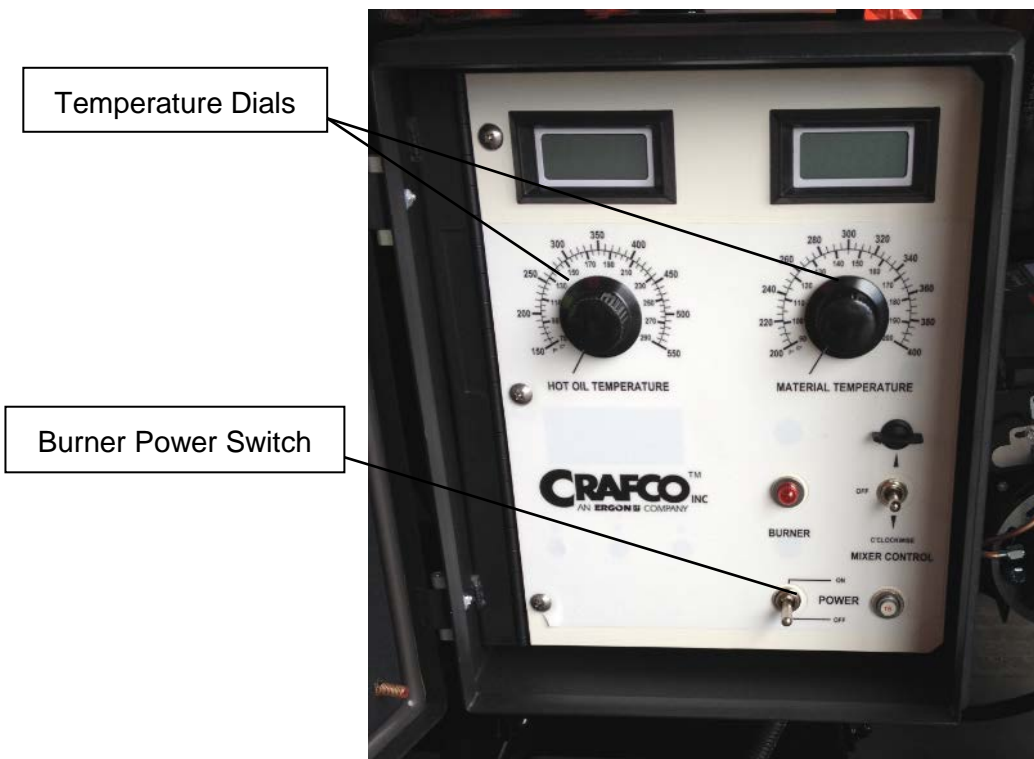

Figure 5-8 Control Panel

Chapter 5 Operating Instructions

5.4 Altitude Compensation System

This unit may be equipped with an Altitude Compensation System. If so, there will be a small boxed housing mounted right below the engine start key panel on the engine mount cross member. The system is automatic during most operating conditions. However, if the machine is taken from above or below an altitude of 2,624 ft. (800 Meters) while the engine is running, the engine will need to be stopped and then restarted. There is a yellow indicator light that illuminates when the machine is above 2,624 ft. (800 Meters) indicating that the system is active.

5.5 Loading Material into Material Tank

This unit is equipped with a safety interlock system on the loading door. This system disables the mixer hydraulic system when the lid is open. This is a safety feature for the operator and should never be disabled for any reason. **Note:** Units with the European Spec are not equipped with this system.

WARNING

Personal injury could occur if this safety system is disabled.

Table 5-3 Loading Material into the Material Tank

Step	Action
	WARNING
	Following this procedure prevents hot material from getting on operators and causing severe burns.
1	To load material into the material tank, first open the lid. Note: The mixer stops when the lid is opened to load solid material into the material tank. European Spec units need to manually stop the mixer before opening the lid.
2	Place the solid material on the lid, then close the lid. Add the desired amount of material. Not more than 10 at a time, without mixing and heating the material. See Figure 5.9 Loading Material Using the Lid
3	Engage the mixer by moving the Mixer Control Switch to clockwise or c'lockwise rotation.
	Note: If blocks of solid material are added too quickly, jamming results and slows down the melting process. The mixer control switch can be moved for opposite rotation.
4	The speed of mixing is controlled by the Flow Control Valve. See Figure 5.10 Flow Control Valve . To adjust the speed, rotate the knob to the desired setting.
5	Allow the mixer to continually rotate as you add blocks, and while the machine is in use. It will help keep the aggregate suspended in the mixture. Note: If you don't run the mixer, the aggregate will settle to the bottom and produce low quality patches.
	CAUTION
	A block of material could cause the lid to open while it is mixing. If this happens, it will automatically stop the mixer. You will need to open the lid and use a scraping tool to push it back down in the tank. You may need to change the direction of the mixer using the control switch so it pulls the block back down into the tank after the lid is closed.

Chapter 5 Operating Instructions

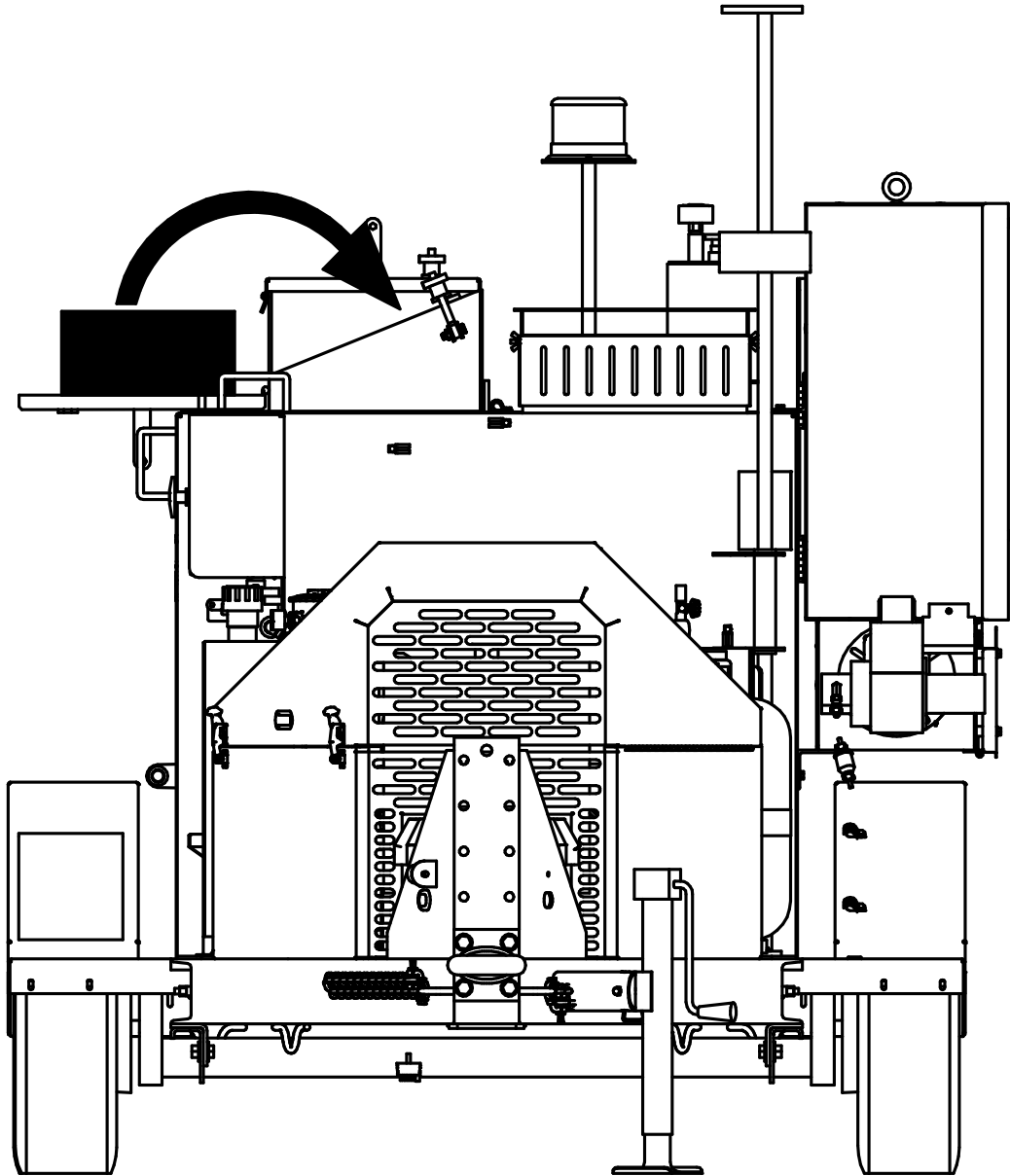

Figure 5-9 Loading Material Using the Lid

Chapter 5 Operating Instructions

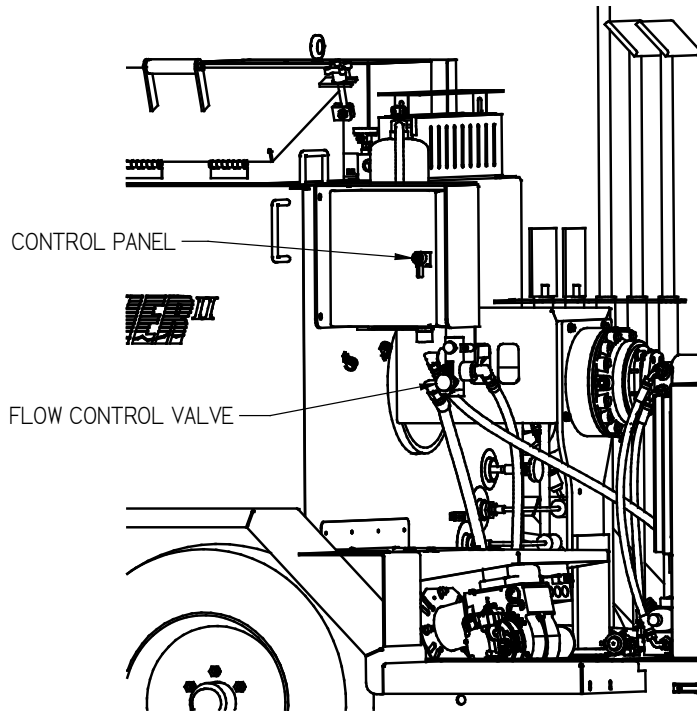



Figure 5-10 Flow Control Valve

5.6 Dispensing the Material

Table 5-4 Dispensing the Material

Step	Action
WARNING	
	<p>Put on protective clothing, gloves, hard-soled shoes, and face shield or safety glasses when operating or filling this machine. Read the entire manual before operating the machine.</p> <p>Hot material can cause severe burns.</p>
1	<p>Allow the material to reach proper operating temperatures according to the manufacturer. Ensure the mixture is fully melted and mixed thoroughly. Draw off material by moving the handle up on the discharge gate.</p>
<p>Important: The material temperature sensor is located by the wall where the heat is coming from. Because of this factor, the material temperature readout on the control panel could be reading higher than what the majority of the material is actually at. The readout should only be used as a guide. A hand held non-contact infrared thermometer should be used on a sample of dispensed material to determine if appropriate application temperature has been achieved. If the application temperature has not been reached, continue heating until it does.</p>	

Chapter 5 Operating Instructions

Table 5-4 Dispensing the Material (continued)

Step	Action
2	Drain material into the patch, pour bucket, shoebox or Hot Mastic Applicator.
3	Remove excess patching material from chute with scraping tool.

5.7 Shutting Down and Cleaning Out the Machine

When shutting down the machine for the day, Crafco recommends emptying all, if not most of the material before shutting down the machine. It will result in faster start up times in the morning, help keep the aggregate from settling at the bottom, and offer better material performance by using fresh material.

Table 5-5 Shutting Down and Cleaning Out the Machine

Step	Action
1	Turn burner toggle switch to "OFF"
2	Return mixer switch to "OFF" position.
3	Idle down the engine with the throttle knob, and turn off engine by turning off the key.
4	Drain un-used material out of discharge gate.
	WARNING
	DO NOT put the tank scraper tool into the discharge pipe with mixer running. Serious damage and personal injury will result.
5	Periodically, you will want to use the tank scraper tool to clean out old material from the bottom of the tank.

5.8 Storing the Machine

Store the machine in an area where moisture cannot enter the heating system, i.e. the heat transfer oil tank, etc. Extended down time can cause moisture to build up in the heating tank.

Evidence that moisture has collected in the heat transfer oil is a constant popping noise. If this popping noise is heard, warm the heat transfer oil to 300°F for two to three hours to evaporate the moisture. Failure to follow this procedure will cause the heat transfer oil to overflow the tank, resulting in possible machine damage and/or personal injury.

Before initial startup after storing the machine for an extended period of time, Crafco recommends to check the material tank and remove any water/moisture that may have collected. Then heat the material to 300°F for two to three hours to evaporate any moisture that could be left in the material tank, even if none was noticed upon inspection. Failure to follow this procedure will cause the material to overflow the tank, resulting in possible machine damage and/or personal injury.

Store the machine for longer periods with the material tank empty.

Chapter 5 Operating Instructions

5.9 Overnight Heaters

An overnight heater rod is available as an option. PN 24190 for 110V, and PN 24194 for 220V. The overnight heater may be used to maintain an overnight heat transfer oil temperature of approximately 200-250°F (93.3°C)

Table 5-6 Overnight Heaters

Step	Action
	<p style="text-align: center;">WARNING</p> <p>The overnight heaters are for overnight use only. If the overnight heater is used, the material must be dispensed the next day. If the material can't be dispensed, the machine needs to be heated to mixing temperatures, and agitated to prevent settling. If you don't dispense the material after 1 nights use, you risk damaging the material and possibly the machine due to settled material, which can harden in the bottom of the material tank</p>
1	Attach each heater power cord to a suitable extension cord.
2	Attach each extension cord to its own outlet rated for 15 amps.
	<p style="text-align: center;">CAUTION</p> <p>Attaching both heaters to the same outlet will most likely pop the circuit breaker inline from the power source. Combining both heaters together will draw too much amperage for most common 15 amp circuits.</p> <p style="text-align: center;">WARNING</p> <p>Suitable extension cord size requirements for 110 Volt use: 25-50 FT • 16-20 Amps • 12 Gauge (Heavy Duty) or 10 Gauge (Extra Heavy Duty) 100 FT • 16-20 Amps • 10 Gauge (Extra Heavy Duty)</p> <p>Suitable extension cord size requirements for 220 Volt use: 25-50 FT • 8-10 Amps • 14 Gauge (Medium Duty) or 12 Gauge (Heavy Duty) 100 FT • 8-10 Amps • 12 Gauge (Heavy Duty)</p> <p>Failure to use the correct size extension cord could result in damage and possible fire!</p>
3	Disconnect the heaters when using the machine's burner system.
	<p style="text-align: center;">CAUTION</p> <p>Do not use the heaters without heat transfer oil in the tank. Doing so will overheat and damage the heaters, and they will have to be replaced.</p>

Chapter 5 Operating Instructions

5.10 Hot Applied Patching Material Placement

Prior to the material application, you will need to move the equipment to the work area. The items needed are:

1. Compressor
2. Saw to cut out repair area
3. Pneumatic hammer
4. Broom and shovels to clean up area
5. Broom or sweeper (if required to remove FOD)
6. Patcher II machine, material, and application tools
7. Dressing stone
8. Heat lance
9. Primer
10. "Hudson" sprayer for the primer
11. Paint brushes
12. Small paint cans
13. Rags
14. 1 or 2 gallons of water (to speed up cooling process if required)
15. Gloves, heavy welder gloves and standard leather gloves
16. Cloth duct tape
17. Reference materials

Chapter 5 Operating Instructions

5.11 Application Steps

Table 5-7 Application Steps

Step	Action
1	Locate area to be repaired.
2	Calculate the amount of material needed for the repairs.
3	Place bags or cubes of material into the mixer and heat. Start the agitator as soon as possible to break up the bags. The heat up time is usually within 60-90 minutes. Care should be taken not to overheat the material. If material temperature is too high, lower the burner material temperature control and/or open the lid
4	Mark the areas to be cut out. Make sure you cut out enough of the pavement to remove all cracking around the patch area. If the repair area extends to both sides of a joint, the repair area must be a minimum of 4" on each side of the joint.
5	Cut with either a wet or dry saw. The saw should cut a minimum of 1-1/2" to 2" deep.
6	Remove the remaining material with a chipping or jack hammer to a minimum depth of 1-1/2 to 2".
7	After the repair area has all the loose material removed, use the hot air lance to clean and dry the pavement.
8	Apply tape 1/4" from the edge of the prepared area.
9	Prime the area with the Primer using the "Hudson" sprayer or paint brushes. If spraying the primer on repair areas, you may need to do some touch-up with a paint brush. When touching up, you want to cover any missed spots and spread any pooled primer. Allow the primer to set up, which takes about 10-12 minutes. DO NOT DRY WITH A TORCH.
10	Have the tools needed for the repair heating in the heated box.
11	Remove at least two pails of product and pour back into the melter. This will ensure a good flow of material when you start the application.
12	Apply the first lift of material to the repair. Apply adequate material so you get material within 1" of surface.
13	Allow the material to cool for a period of time, allowing air bubbles to move to the surface of the product. The bubbles are generated from uncured primer, air, or moisture. When the bubbles stop rising to the surface (usually within 15-20 minutes), flash surface with hand torch to "pop" bubbles.
14	Apply the next level and float surface of the material with the hot irons. Seal the edges of the repair by pulling liquid to the edge, and then remove the duct tape. The main portion of the material will self-level, but you may need to do some smoothing with the hot iron to ensure a level surface.

Chapter 5 Operating Instructions

Table 5-8 Application Steps Continued

Step	Action
15	Allow this material to cool similar to the first lift - you may not experience as many bubbles this time but some may appear. When they do, flash them with the torch.
16	If applicable, dry the aggregate dressing prior to placing the material, as wet or damp dressing will not adhere. Smooth the aggregate dressing material over the patched area with your gloved hand. This will ensure coverage of the whole surface of the material.
	CAUTION
	If you applied the aggregate dressing material too soon the bubbles will continue to rise to the surface and pop, leaving a pock marked surface. If this occurs, adjust your timing to allow more bubbles to break the surface.
17	Shut down the Patcher II and clean up the repaired area. If the cooling time of the material needs to be shortened, broadcast some water over the surface.
18	Sweep excess aggregate dressing material from the surface of the repair and finish clean up.
	CAUTION
	When transporting the machine long distances with hot material in the tank, always close and lock the discharge gate with the safety chain. This will prevent material from spilling out while transporting. Also, when transporting the machine with hot material in the tank, the mixer should be engaged until the material temperature cools to 250°F or material separation will occur. Never leave the burner turned on when transporting the machine. It will damage the burner.
	CAUTION
	The tool heater box is only meant to heat up the tools. Do not use the box to clean the tools. Before inserting the tools into the box, use the hand torch to clean off excess material. This will help keep material from building up in the bottom of the box.

Chapter 5 Operating Instructions

5.12 Material Tank Depth to Capacity Chart

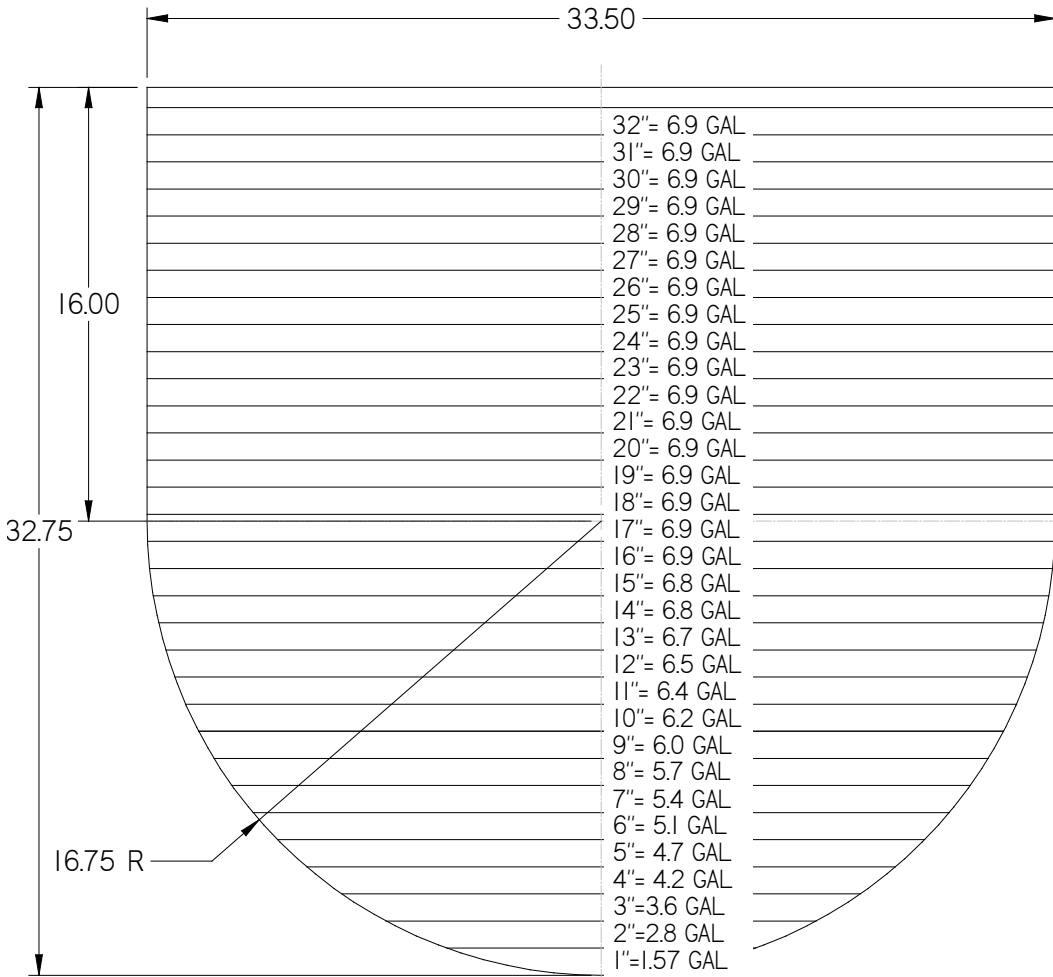

MATERIAL TANK DEPTH TO CAPACITY CHART		
DEPTH OF MATERIAL	CAPACITY IN GALLONS	CAPACITY IN LITERS
1"	1.6	6.0
2"	4.4	16.7
3"	8.0	30.4
4"	12.2	46.3
5"	16.9	64.1
6"	22.0	83.4
7"	27.5	104.0
8"	33.2	125.7
9"	39.2	148.4
10"	45.4	171.9
11"	51.8	196.1
12"	58.3	220.9
13"	65.0	246.1
14"	71.8	271.7
15"	78.6	297.5
16"	85.5	323.5
17"	92.3	349.6
18"	99.2	375.6
19"	106.1	401.7
20"	113.0	427.8
21"	119.9	453.9
22"	126.8	479.9
23"	133.7	506.0
24"	140.6	532.1
25"	147.5	558.2
26"	154.3	584.2
27"	161.2	610.3
28"	168.1	636.4
29"	175.0	662.5
30"	181.9	688.6
31"	188.8	714.6
32"	195.7	740.7
32.75"	200.8	760.1

Figure 5-11 Material Tank Depth to Capacity Chart

Chapter 5 Operating Instructions

5.13 Removing Optional Heated Chute

If desired, your Patcher II will have a heated chute kit already installed from the factory. If you want to remove the heated chute from the machine, you must follow the steps below, or injury to operators and damage to your machine could result. You can set it up for temporary use with a minimal amount of changes in approx. 15 minutes, or completely remove all of the parts from the machine in about 1 hour depending on your future job requirements.

Table 5-9 Temporary Removal of Optional Heated Chute

Step	Action
	WARNING
	Following this procedure prevents hot oil from getting on operators and causing severe burns. Never operate the machine without the heat transfer oil lines connected correctly. Never use the heat transfer oil valves to be the only method of stopping oil flow while the machine is operated. They are only used to stop flow to change the heat transfer oil lines when the machine is cool, and not operating.
	CAUTION
	Following this procedure prevents damage to the machine from operating the machine with the hydraulic and heat transfer oil lines not connected correctly.
1	Make sure the engine and burners are powered off. Make sure the machine and heat transfer oil has cooled to ambient temperatures before attempting to remove the chute.
2	Close both of the heat transfer oil ball valves.
3	Remove the heat transfer oil line (steel braided line covered in fire sleeve) coming out of the pump to the chute, at the chute fitting. Some heat transfer oil will leak from the lines.
4	Remove the other heat transfer oil line from the swivel fitting on the end of the ball valve
5	Connect the loose heat transfer oil line from the pump to the open swivel fitting on the end of the ball valve. You should have this line connected from the swivel fitting on the pump to the swivel fitting on the ball valve to loop the flow of heat transfer oil back into the tank. Secure the line to prevent it from damage.
6	Open the ball valves to allow the heat transfer oil to flow during machine operation. Make sure your connections are tight and leak free.
7	Remove the hitch pin from the receiver and slide out the heated chute assembly. Refer to Figure 9.18 Optional Heated Chute for more info. The machine can now safely be used.
8	To install the chute, reverse these steps.

Chapter 5 Operating Instructions

Table 5-10 Complete Removal of Optional Heated Chute

Step	Action
	WARNING
	<p>Following this procedure prevents hot oil from getting on operators and causing severe burns. Never operate the machine without the heat transfer oil lines connected correctly. Never use the heat transfer oil valves to be the only method of stopping oil flow while the machine is operated. They are only used to stop flow to change the heat transfer oil lines when the machine is cool, and not operating.</p>
	CAUTION
	<p>Following this procedure prevents damage to the machine from operating the machine with the hydraulic and heat transfer oil lines not connected correctly.</p>
1	<p>Make sure the engine and burners are powered off. Make sure the machine and heat transfer oil has cooled to ambient temperatures before attempting to remove the chute.</p>
2	<p>Close both of the heat transfer oil ball valves.</p>
3	<p>Remove both the heat transfer oil lines (steel braided line covered in fire sleeve) coming out of the ball valves. Some heat transfer oil will leak from the lines. You need to install threaded caps over the exposed fittings, or connect one of the heat transfer oil lines to act as a loop between the two fittings. Tighten the fittings and secure the line out of the way. Open the heat transfer oil valves.</p>
4	<p>Remove one of the hydraulic lines from the motor. Remove the opposite hydraulic line from the bulkhead fitting near the bottom of the frame. Hydraulic fluid will leak from the lines.</p>
5	<p>Quickly connect the hydraulic line that is still connected to the bulkhead fitting to the other bulkhead fitting to loop the hydraulic flow. Tighten the fittings and make sure they are leak free.</p>
6	<p>Remove the motor and pump assembly, chute assembly, hitch mounting plate assembly, and the chute support assembly from the machine.</p>
7	<p>Once you are finished, you should have the heat transfer oil ball valves capped or looped, and the hydraulic bulkhead fittings looped. Check to make sure all the fittings are tight.</p>
8	<p>Check and top off the heat transfer oil and hydraulic fluids to their proper fill levels.</p>
9	<p>The machine can now safely be used. Refer to Figure 9.18 Optional Heated Chute for more info.</p>
10	<p>To install the chute, reverse these steps.</p>

Chapter 5 Operating Instructions

5.14 Mounting a Skid Machine

Table 5-11 Mounting a Skid Machine

Step	Action
	<p style="text-align: center;">WARNING</p> <p>The truck needs to be of proper size to hold the loaded weight and size of the machine and any extra material to be carried. The center of gravity of the loaded machine should be above or in front of the rear main axle. Contact CrafcO for help in determining the location of the center of gravity of your machine before mounting.</p> <p style="text-align: center;">WARNING</p> <p>Only mount the unit to a metal truck bed or any other non-flammable surface that can support the weight of the machine.</p> <p>Failure to use the correct mounting surface could result in damage and possible fire!</p> <p style="text-align: center;">WARNING</p> <p>Mount the machine a minimum of 3" (76mm) above the truck bed. Depending on the machine and airflow, you may have to mount it higher to prevent excessive temperatures on the machine and truck bed.</p>
1	<p>Mount with four ½" diameter Grade 5 bolts (or 12mm Grade 10.9) minimum, using the loading tubes at each corner of the machine to secure it in place.</p>
	<p style="text-align: center;">WARNING</p> <p>Leave 15" (381mm) clearance around the machine. Keep this area clear of any flammable material such as empty sealant boxes.</p> <p>Failure to keep this area clear could result in damage and possible fire!</p>

TYPICAL SKID MOUNT GUIDELINES

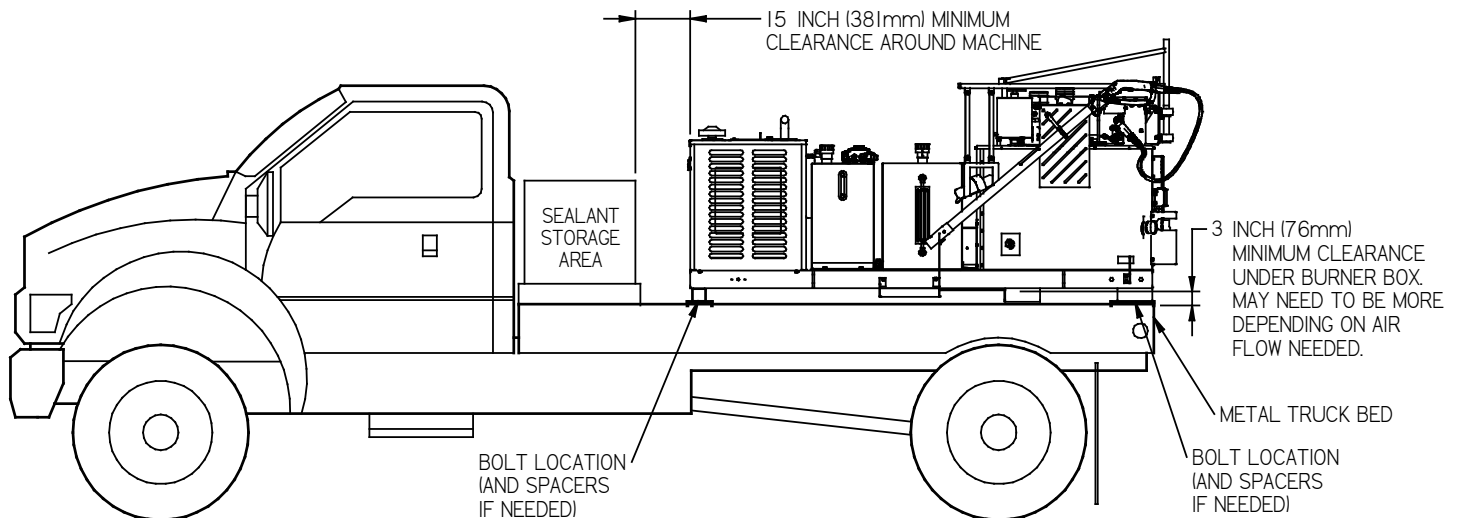

Chapter 6 Maintenance Instructions

6.0 Maintenance Instructions

This chapter contains all normal maintenance instructions to properly maintain your machine.

6.1 Engine

Check oil daily. Service engine per the Isuzu owner's manual. See engine owner's manual for additional operating and maintenance instructions.

6.2 Hydraulic System

Check hydraulic fluid daily.

Change hydraulic filter every 250 hours of machine operation.

Change hydraulic fluid every 500 hours of operation.

6.3 Heat Transfer Oil

Check the oil level at the start of every day.

Change the oil every 500 hours of machine operation or 1 year, whichever comes first.

6.4 Mixer Packing Gland Seals

Tighten gland while machine is hot at 50 hr. intervals. Do not overtighten. If material is leaking from the seals, they either need to be tightened or more gland packing added, and then tightened.

6.5 Mixer Shaft Bearings

Lubricate weekly using Crafcro Part No. 56860 high temperature bearing grease.

6.6 Material Sensor Tube

Check for heat transfer oil in tube every 50 hours of operation. 2 ounces required.

6.7 Lug Nuts

Torque all nuts/bolts before first road use and after each wheel removal. Check and torque after the first 10 miles, 25 miles, and again at 50 miles. Check periodically thereafter.

Torque in stages as follows:

- First stage 20-25 foot-pound (ft-lb)
- Second stage 50-60 foot pound (ft-lb)
- Third stage 90-120 foot pound (ft-lb)

Tighten bolts and nuts in the sequence shown in [Figure 6.1 Lug Bolt Tightening Sequence](#)

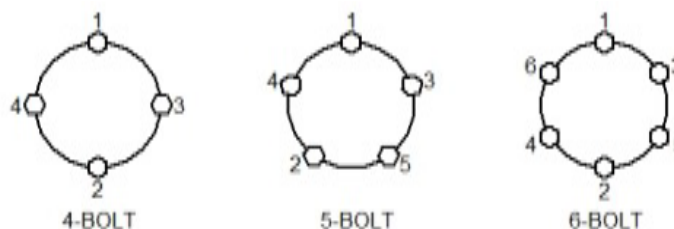

Figure 6-1 Lug Bolt Tightening Sequence

Chapter 6 Maintenance Instructions

6.8 Wheel Bearing

Pack the wheel bearing every 24,000 miles or every two years, whichever comes first. Use a good grade of bearing grease.

6.9 Brakes

Check the brakes daily.

6.10 Tongue Jack

Lubricate the tongue jack, using a good grade of bearing grease.

6.11 Water Separator

Check the water separator for excess water in the housing. If the red ring is up half way on the canister, then it needs to be drained out. To drain, turn "OFF" the valve, remove the ring that holds the canister in place, dump out the fuel and water mixture. Then replace the canister with the threaded ring, and turn "ON" the fuel valve.

6.12 Temperature Control Calibration

Check the control knob calibration weekly. Calibrate by turning the knob counterclockwise. If the marks do not align, loosen screw in knob and align the line on the control knob with the calibration mark on the scale plate. See [Figure 6.2 Temperature Control Calibration](#)

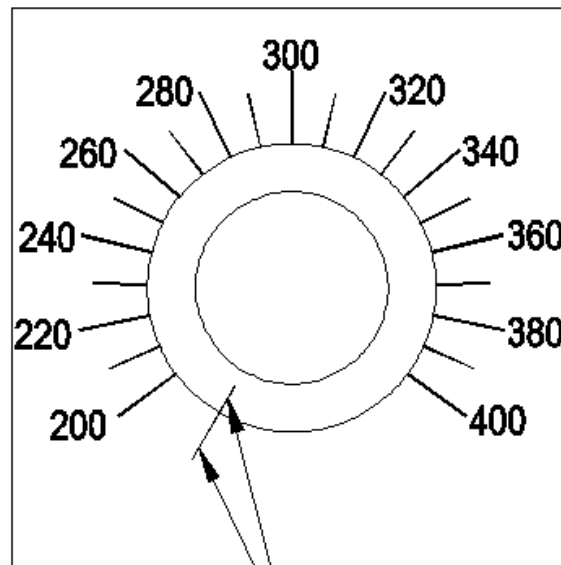

Calibration Mark

Figure 6-2 Temperature Control Calibration

Chapter 6 Maintenance Instructions

6.13 Maintenance Chart

Table 6-1 Maintenance Chart

Location	Procedure	Hours			
		8	50	250	500
Engine check oil level	Refer to the manufacturer's instructions for the engine	X			
Other engine maintenance	Refer to the manufacture's operating and maintenance instructions for the engine.				
Material Sensor Tube	Check for Heat Transfer Oil		X		
	Add	As needed			
Heat Transfer Oil	Check	X			
	Change				X
Hydraulic Oil	Check	X			
	Change				X
Gear Box Oil	Check	X			
	Change				X
Hydraulic Oil Filter	Change			X	
Burner	Check burner box insulation				X
	Clean CAD cell				X
	Check Electrodes, and Head				X
	Replace burner nozzle				X
Mixer Shaft Packing	Tighten when hot at 50 hour intervals. Do not over tighten.		X		
Mixer Shaft Bearings	Grease using CrafcO Part No. 56860 Hi-Temp grease.		X		
Wheel Bearings	Clean and re-pack using a good grade of bearing grease.	Every 24,000 miles or two years			
Tongue Jack	Grease using a good grade of bearing grease.	Once a year			
Material Tank	Scrape out tank to remove all old material.				X
Material Sensor Guard	Scrape out built up material around guard.				X
Heated Tool Box	Clean out material drippings. Replace insulation as needed. PN 57474N and PN 57479N	X			

See [Table 6-5 General Maintenance Parts](#) for more info on part numbers.

Chapter 6 Maintenance Instructions

Table 6-2 Maintenance Chart (continued)

Location	Procedure	Hours			
		8	50	250	500
Water Separator	If red ring is half way up the body then drain.		X		
Adjusting Discharge Gate	Check and adjust if leaking		X		

6.14 Service Instructions

Table 6-3 Service Instructions

Step	Action
1	Do a general inspection of the machine at least once a week.
2	Replace all worn or damaged parts. Note: Keep regular replacement items in stock for emergency repairs to prevent costly downtime. See Table 6-6 Recommended Spare Parts
3	Make necessary adjustments and tighten all loose nuts or screws.
4	Watch for leaks. Tighten fittings or repair as necessary.
5	Clean the external surfaces of the machine at regular intervals. Note: Refer to the material manufacturer's instructions for recommendations.
6	Follow the recommended maintenance per Table 6-1 Maintenance Chart

For service, find a list of authorized Distributors and service centers at Crafco.com/Distributors.

6.15 Recommended Fluids and Lubricants

Table 6-4 Recommended Fluids and Lubricants

Application	Recommended	Full Point
Engine Oil	Refer to engine manual	3 Qts.
Hydraulic Oil	Shell AW Hydraulic 46	12 Gals.
Heat Transfer Oil	Shell Turbo T 68 (Group II)	35 Gals.
Gear Box Oil	85W-140 Gear Oil	1 Qt.

Chapter 6 Maintenance Instructions

6.16 General Maintenance Parts

Table 6-5 General Maintenance Parts

Recommended Quantity	Description	Part No.
10.25"ea., 4per location	Packing, Mixer Shaft	32226
1	Main Burner Nozzle (2.25)	44785
1	Tool Box Burner Nozzle (0.5)	32403
1	Tool Box Burner Replacement Insulation	57474N
1	Tool Box Burner Door Replacement Insulation	57479N
1	Fuel Filter (Tool Box Burner)	56932
1	Hydraulic Return Line Filter	45438
1	Engine Air Filter	45391
1	Engine Oil Filter	45389
1	Engine Mounted Fuel Filter	41867
1	Water Separator Housing	47150

6.17 Recommended Spare Parts

Table 6-6 Recommended Spare Parts

Recommended Quantity	Description	Part No.
1	DC Controller	42335
1	Autostop Lid Switch	39608
1	Burner Fuel Pump Coupling	41970
1	Temp Controller, Material	57863
1	Temp Controller, Hot Oil	43391
1	Burner Solenoid	39602
1	Fuel Filter (Tool Box Burner)	56932

Chapter 6 Maintenance Instructions

6.18 Applicable Brands of Heat Transfer Oil

Table 6-7 Applicable Brand of Heat Transfer Oil

Manufacturer	Product Name	Crafco Heat Transfer Fluid
Chevron	Heat Transfer Oil Grade 46	Shell Turbo T 68 (Group II)
Citgo	Hytherm Oil 46	Shell Turbo T 68 (Group II)
Conoco	Hydroclear Heat Transfer Oil	Shell Turbo T 68 (Group II)
Fina	Vulcan Heat Transfer Oil 46	Shell Turbo T 68 (Group II)
Lubrication Engineers	Heat Transfer Oil	Shell Turbo T 68 (Group II)
Exxon Mobile	Caloria HT 43	Shell Turbo T 68 (Group II)
Mobil	Mobiltherm 43	Shell Turbo T 68 (Group II)
Mobil	Mobiltherm 603	Shell Turbo T 68 (Group II)
Phillips 66	Heat Transfer Oil #3`	Shell Turbo T 68 (Group II)
Phillips 66	Magnus Oil 68	Shell Turbo T 68 (Group II)

CAUTION

The heat transfer oil in this machine is a grade that has been tested and recommended by Crafco, Inc. Using a grade of oil not specifically recommended by Crafco, Inc., is cause for warranties to be voided.

All oils subjected to high temperatures deteriorate with time and lose many of their characteristics. Tests conducted by Crafco, Inc. have determined that for best results and safety, the heat transfer oil in this machine must be drained and replaced with Crafco, Inc. recommended oil after five hundred (500) hours of machine operation or one (1) year, whichever occurs first.

6.19 Typical Heat Transfer Oil Specifications

Table 6-8 Typical Heat Transfer Oil Specifications

ISO	68
Flash Point, COC	445°F
Viscosity @ 100°F-SUS	325
Viscosity @ 210°F-SUS	50
Viscosity Index	95-100
Pour Point	0°F
Carbon residue	1%

Chapter 6 Maintenance Instructions

6.20 Adjusting the Discharge Gate

Due to normal wear and tear, the discharge gate will need periodic adjustment to keep it sealed. It features a double nut tightening system. If the gate is leaking material excessively, you will need to adjust the nuts so it can re-form a seal when closed.

Table 6-9 Adjusting the Discharge Gate

Step	Action
	<p>WARNING</p> <p>The material in the material tank is extremely hot. Bodily contact with hot material can cause severe burns.</p> <p>The high operating temperatures of this machine and the material it contains require that protective clothing, gloves, hard-soled shoes, and safety glasses or a face shield be worn at all times while maintaining the machine.</p>
1	While the machine is at operating temperature, loosen the outer most nut. Then tighten the inner most nut.
2	Open and close the discharge gate a few times to clean off the sealing surfaces.
	<p>Note: If there is material in the machine, make sure to place a bucket below the chute to collect any material that comes out. You may also want to use a torch to clean off any built up material from the discharge gate area.</p>
3	As you open and close the gate, it should take less force as the sealing surfaces clean themselves. With the gate closed, tighten the inner nut again.
4	Open and close the gate a few more times, making sure the gate operates smoothly, and the sealing surfaces are clean of any aggregate.
5	Once the sealing surfaces are clean, you will want to tighten the nut so that the gate operates smoothly with a little resistance. It should not be loose.
6	Once you have the inner nut set to your desired resistance, you will need 2 wrenches. Use one to hold the inner nut in position, and then tighten the outer nut to lock it.
7	Open and close the gate. It should operate smoothly, and not allow any excessive material to leak.

Chapter 6 Maintenance Instructions

6.21 Adjusting and Replacing Mixer Shaft Packing

Table 6-10 Adjusting and Replacing Mixer Shaft Packing

Step	Action
1	Bring the Patcher II to temperature as preparation to drain the material tank below the mixer shaft level.
2	Drain material until the level is below the mixer shaft so material will not leak out during replacement.
WARNING	
	<p>The material in the material tank is extremely hot. Bodily contact with hot material can cause severe burns.</p> <p>The high operating temperatures of this machine and the material it contains require that protective clothing, gloves, hard-soled shoes, and safety glasses or a face shield be worn at all times by operators of the machine.</p>
3	Set the heat transfer oil temperature to 150 degrees, and let it cool down to that temperature.
4	Start with the back seal area first on the back of the machine. You will have to unbolt the bearing, loosen the set screw on the bearing, and slide the bearing off the back of the machine.
5	Remove the 4 nuts that hold each packing gland assembly in place, and pull the packing gland assembly off of the shaft.
6	Cut the rope seal to 10.25" long. Wrap the new packing seal around the shaft with the seam at least 90° from of the existing seam seal and push it into the seal cup. You can use the packing gland assembly to help push it in. When the machine is new, it has four of the 10.25" wraps in each seal area.
7	Align the packing gland assembly with the studs, and slide it into place. Tighten down the 4 nuts in a cross pattern until they are reasonably tight.
8	Re-install the bearing, and tighten the mounting bolts and set screw.
9	Go to the front of the machine, unbolt and slide the bearing back and loosen the packing gland assembly nuts. Then slide the gland towards the bearing.
10	Wrap the new packing seal around the shaft, and push it into the cup as you did before.
11	Align the packing gland assembly with the studs, and slide it into place. Tighten down the 4 nuts in a cross pattern until they are reasonably tight. Then slide the bearing back into place and tighten the mounting bolts and set screws.
12	Heat up and use the machine as normal. You may need to tighten the packing gland assembly nuts after some use, or if they weren't tightened enough after replacement. There should not be any material leaking from the packing seal area.
13	Run the mixer shaft and check for any leaking. If it leaks, you need to tighten the nuts in a cross pattern until the leaking stops. Make sure not to over tighten the packing or premature wear of the shaft could result.

Chapter 6 Maintenance Instructions

6.22 Cleaning Material Tank and Sensor Area

The material tank needs to be cleaned every year or as needed for proper operation. As the machine is used, material builds up around the tank walls and sensor guard. The built up material prevents heat from getting to the fresh material and causes longer heat up times. The built up material will also prevent the material temperature sensor from reading as accurately because it becomes insulated from the fresh material. The coked material needs to be scraped or chipped from the tank walls. The area between the sensor and sensor guard needs to be cleaned also for proper temperature sensing. An air chisel with various sized blades usually works best to break up the material and remove it from the walls. Once the walls and sensor guard areas are cleaned, remove all the loose chunks from the tank, and vacuum out any smaller pieces.

6.23 Cleaning the Melter

We recommend using Orange-Sol industrial cleaner for cleaning the exterior of the machine. The cleaner can be found at the following website; <https://www.orange-sol.com/industrial-formula/>.

Chapter 7 How to Use a Multimeter

7.0 How to Use a Multimeter

CrafcO machines use 12-volt direct current (DC) to power the burner, hydraulic valves, and trigger on electric wand. The DC power is from a 12-volt battery.

If equipped, the electric hose and wand uses 24-volt 3-phase alternating current (AC). The AC power is from the generator which hangs under the radiator. This system has no reference to ground so there is no possibility of electrical shock unless you are between 2 of the phases. **NOTE: ONLY CHECK AMPERAGE ON A HOSE WITH A CLAMP-ON AMP METER.**

12-volt DC power has little danger of electrical shock. Care must still be taken when dealing with DC power systems because it is capable of producing large amounts of current.

7.1 Checking DC Voltage with a Multimeter

Connect the probes to the meter.

Set the range to a position that includes 12-volts or higher.

Touch the red probe to the positive side of accessory and black probe to ground. If the item you are checking has a ground wire attached then use that ground or you can use a non-painted surface on the frame.

7.2 Checking AC Voltage with Multimeter

Connect the probes to the meter.

Set the range to a position that includes 24-volts or higher.

There are three steps to test the generator voltage. All 3 values should be in the range of 24-30 volts AC.

- Touch red probe to the white wire of the generator and the black probe to the green wire of the generator.
- Next move black probe to black wire.
- Then move red probe to green wire.

7.3 Checking Resistance (Ohms)

Connect the probes to the meter. See [Figure 7.1 Standard Multimeter](#).

Note: When checking Ohms, the circuit cannot be completed. This means one end of the wire will need to be disconnected.

7.3.1 How to Check Wire Continuity

Set the meter to “Audible Continuity”. Now touch the probe to each end of the wire in question. The meter will read “0” on the screen and make an audible beep if the wire has continuity from end to end.

7.3.2 How to Check RTD Sensor

Set dial to Ohms Ω . If your meter has different ranges, set to 2k or 2000 ohm range. Touch one probe to each screw or wire of the sensor. The meter will read X.XX if in the 2k range or XXX.X if in the 2000 range.

Chapter 7 How to Use a Multimeter

7.4 Checking Amperage

The Multimeter can be used to check amperages under 10 amps in AC or DC current. When checking the amperage of the electric hose **always use a clamp-on amp meter**. The amperage in the hose can reach as high as 35 amps. Clamp the meter around one wire at a time. Remember most clamp-on meters do not work on DC current.

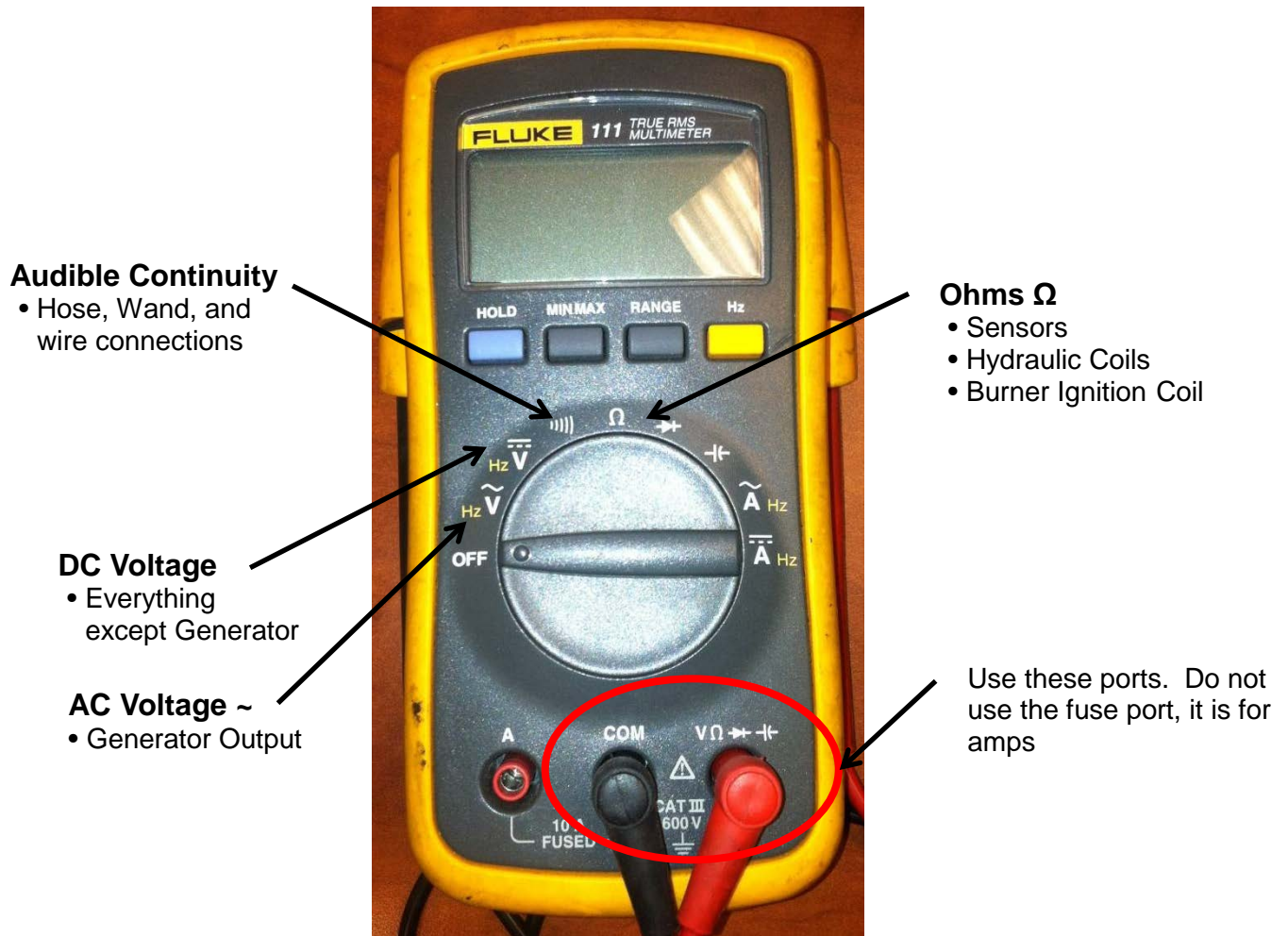

Figure 7-1 Standard Multimeter

Chapter 7 How to Use a Multimeter

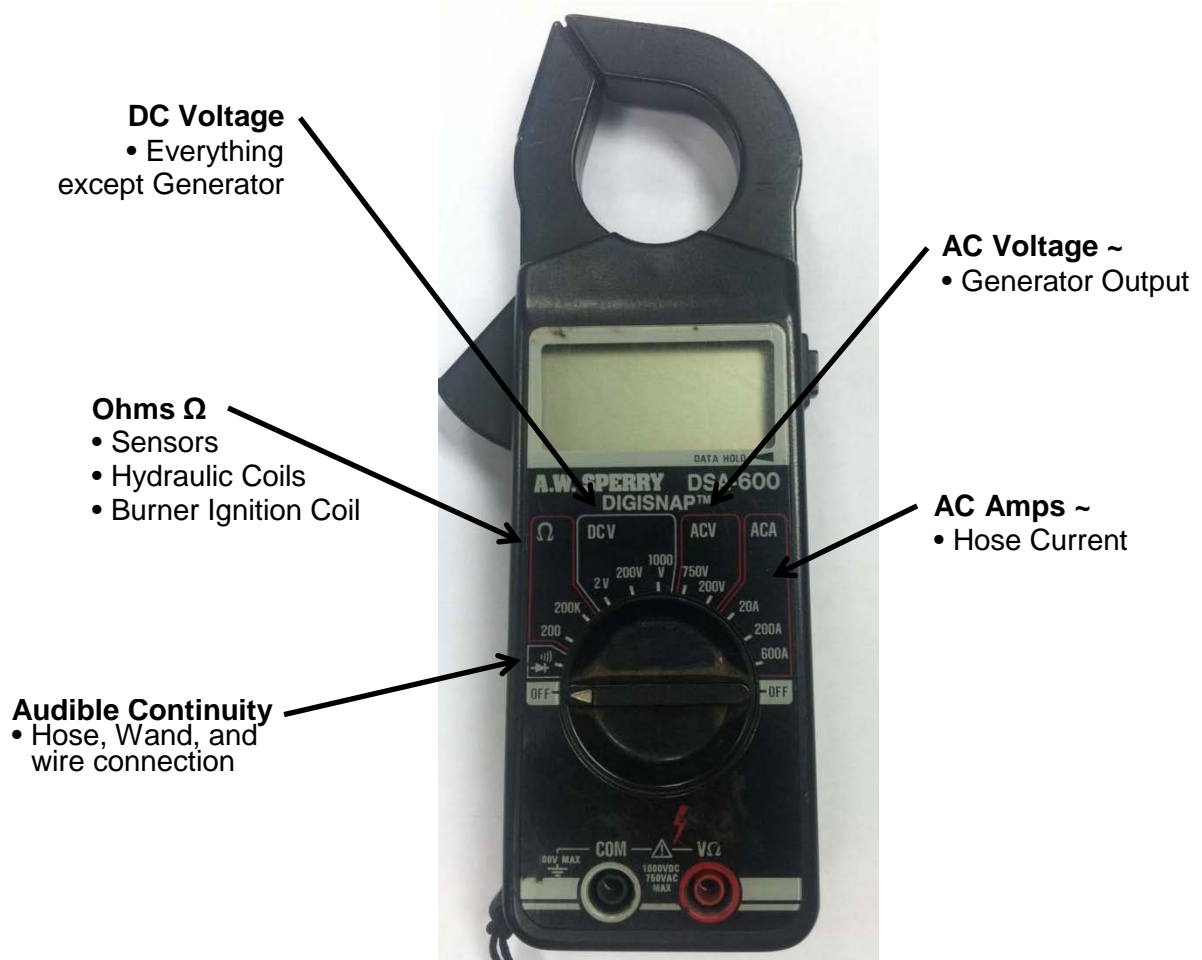

Figure 7-2 Clamp-On Amp Meter/Multimeter

Chapter 8 Troubleshooting

8.0 Troubleshooting

8.1 Burner Troubleshooting

8.1.1 Symptom: Burner will Not Ignite

Table 8-1 Burner Basic Visual Troubleshooting

Step	Possible Cause	If . . .
1	Start Troubleshooting at the control box. Is the engine running?	<ul style="list-style-type: none"> • Yes, go to Step 2. • No, start the engine. • NOTE: You can troubleshoot the burner without the engine running, but you must hook a battery charger to the battery and turn the ignition key to the "ON" position.
2	Is the "POWER" toggle switch in the "ON" position?	<ul style="list-style-type: none"> • Yes, go to Step 3. • No, turn the toggle switch to the "ON" position
3	Are both the Material and Hot Oil temperature dials set to proper operating temperatures?	<ul style="list-style-type: none"> • Yes, go to Step 4. • No, set the Material according to the type of material you are using and the Hot Oil 100°F above the Material set point.
4	Are both the Material and Hot Oil temperature displays reading a three digit positive number?	<ul style="list-style-type: none"> • Yes, go to Step 5. • No, go to Table 8-2 Burner Electrical Troubleshooting Step 4
5	Is the red "Burner" light "ON"?	<ul style="list-style-type: none"> • Yes, go to Step 6. • No, go to Table 8-2 Burner Electrical Troubleshooting, Step 4
6	Is the diesel tank full?	<ul style="list-style-type: none"> • Yes, go to Step 7. • No, fill your tank or make sure you have enough fuel for the day.
7	Did you run the diesel tank low on fuel or empty?	<ul style="list-style-type: none"> • Yes, you need to bleed your burner, go to Table 8-6 Bleeding the Diesel Burner • No, go to Step 8.
8	Is there smoke coming out of the exhaust stack?	<ul style="list-style-type: none"> • Yes, go to Table 8-7 Smoke Coming Out of the Exhaust Stack • No, go to Step 9.
9	Is your burner working properly, but it seems like it takes a lot to reach operating temperature?	<ul style="list-style-type: none"> • Yes, go to Table 8-9 Material is Heating Slowly • No, Call Crafco, Inc. and speak to a customer service technician.

Chapter 8 Troubleshooting

Table 8-2 Burner Electrical Troubleshooting

Step	Possible Cause	If . . .
1	Is the "POWER" toggle switch in the "ON" position ?	<ul style="list-style-type: none"> • Yes, go to Step 1a. • No, turn the main power switch to the "ON" position.
1a	Is the output voltage at the "POWER" toggle switch 12Vdc? (Refer to the Figure 8.1 Electrical Schematic (PN 26582) .) (Check both the red and orange wires.)	<ul style="list-style-type: none"> • Yes, on both, go to Step 2. • No, see below. • No, on both orange and red wires go to Step 1b. • No, on orange and Yes on red replace "POWER" toggle switch.
1b	Is the circuit breaker tripped?	<ul style="list-style-type: none"> • Yes, reset the circuit breaker by pushing in the button which has popped out. • No, go to Step 1c.
1c	Is the output voltage at the circuit breaker 12Vdc? (Check both red wires).	<ul style="list-style-type: none"> • Yes, on both, go to Step 2. • No, see below. • No, on the red wire between the circuit breaker and the power toggle switch and Yes on the red wire between the circuit breaker and the battery, replace the circuit breaker. • No, on the red wire between the circuit breaker and the battery, go to Step 1d.
1d	Is the output voltage at battery 12Vdc?	<ul style="list-style-type: none"> • Yes, check for broken wires or poor wire crimp at the battery and circuit breaker. • No, your battery doesn't have sufficient charge. Either charge or replace the battery.

Chapter 8 Troubleshooting

Table 8-2 Burner Electrical Troubleshooting (continued)

Step	Possible Cause	If . . .
2	Are both the Material and Hot Oil readouts displaying a three digit number?	<ul style="list-style-type: none"> • Yes, go to Step 3. • No, go to Step 2a.
2a	Is the voltage 12Vdc between the power and the ground on the PAKSTAT for which the display is not reading (material check terminals #3 and #5)? (Hot oil check terminals #3 and #5.)	<ul style="list-style-type: none"> • Yes, go to Step 2b. • No, check for broken wires or poor wire crimp on the power and the ground. • Still No, replace PAKSTAT.
2b	Does the readout display a -1? Note: This occurs only when there is a short in the sensor circuit.	<ul style="list-style-type: none"> • Yes, check the RTD sensor for water or condensation under the cap or corrosion causing a short. • No, go to Step 2c.
2c	Does the readout display a 1? Note: This occurs only when the sensor circuit is not completed.	<ul style="list-style-type: none"> • Yes, this means there is a break in the two wires between the RTD sensor and the PAKSTAT. Start at the sensor and work your way back to the control box, checking for broken wires. • No, go to Step 2d.
2d	Is the readout display blank? (Take note of the direction the red stripe on the ribbon cable is pointing before you move it.)	<ul style="list-style-type: none"> • Yes, move the ribbon cable which is plugged into the back of the readout which is blank to a readout next to it. If the readout displays a three digit number, the blank readout is bad and needs to be replaced. If the readout remains blank, go to Step 2e.
2e	Readout is still blank	<ul style="list-style-type: none"> • Use the other ribbon cable to go between both the first blank readout and the PAKSTAT for that readout. If the readout displays a three digit number, the original ribbon cable is bad and needs to be replaced. If the readout is still blank, the PAKSTAT is bad and needs to be replaced.

Chapter 8 Troubleshooting

Table 8-2 Burner Electrical Troubleshooting (continued)

Step	Possible Cause	If . . .
3	Is there 12Vdc between the Hot Oil PAKSTAT terminal #3 orange wire and terminal #5 black ground wire?	<ul style="list-style-type: none"> • Yes, go to Step 4. • No, check for broken wires or poor wire crimp on the #3 and #5. • Still No, replace the Hot Oil PAKSTAT.
4	Is there 12Vdc between the Hot Oil PAKSTAT terminal #6 gray wire and terminal #5 black ground wire?	<ul style="list-style-type: none"> • Yes, go to Step 5. • No, go to Step 4a.
4a	Is there 12Vdc between the Material PAKSTAT terminal #3 orange wire and terminal #5 black ground wire?	<ul style="list-style-type: none"> • Yes, go to Step 4b. • No, go to Step 4c.
4b	Are there any broken wires or poor wire crimp between the Material PAKSTAT terminal #3 orange and Hot Oil PAKSTAT terminal #6 gray? (Also check the terminal block where this gray wire passes through.)	<ul style="list-style-type: none"> • Yes, repair the damage and then repeat Step 4. • No, call Crafco, Inc. and speak to customer service technician.
4c	Is there 12Vdc between the Material PAKSTAT terminal #3 orange wire and terminal #5 black ground wire?	<ul style="list-style-type: none"> • Yes, check Material PAKSTAT terminal #3 for a broken wire or poor wire crimp. Then recheck for 12Vdc between Material PAKSTAT terminal #3 orange wire and #5 black ground wire. • If still No, replace Material PAKSTAT.
4d	Is there 12Vdc between the Material PAKSTAT terminal #3 orange wire and terminal #5 black ground wire?	<ul style="list-style-type: none"> • Yes, then you should have 12Vdc on Material PAKSTAT terminal #3, check for a broken wire or poor wire crimp. • No, go to Step 4e.
4e	Is there any broken wires or poor wire crimp between the Material PAKSTAT terminal #3 orange wire, terminal #3 orange wire, terminal #5 black ground wire and Hot Oil PAKSTAT terminal #3 orange? (Also check the terminal block where this orange wire passes through.)	<ul style="list-style-type: none"> • Yes, repair the damage and then repeat Step 4a. • No, call Crafco, Inc. and speak to customer service technician.

Chapter 8 Troubleshooting

Table 8-2 Burner Electrical Troubleshooting (continued)

Step	Possible Cause	If . . .
5	Is there 12Vdc between Hot Oil PAKSTAT terminal #7 gray wire and terminal #5 black ground?	<ul style="list-style-type: none"> • Yes, go to Step 6. • No, check for a broken wire or poor wire crimp on Hot Oil PAKSTAT terminal #7 and repeat Step 5. • Still No, then replace Hot Oil PAKSTAT.
6	Is there 12Vdc between the frame solenoid post green wire and red wire and the black ground wire? (The frame solenoid can be located next to the burner.)	<ul style="list-style-type: none"> • Yes, go to Step 7. • No, go to Step 6a.
6a	Are there any broken wires or poor wire crimp between the frame solenoid post green wire and red wire, black ground wire or on the Hot Oil PAKSTAT terminal #7 gray wire? (Also check the terminal block where this green wire passes through and becomes a gray wire inside the control box.)	<ul style="list-style-type: none"> • Yes, repair the damage and then repeat Step 6. • No, call Crafcro, Inc. and speak to customer service technician.
7	Is there 12Vdc between the frame solenoid side post going toward the burner large red wire and the black ground wire?	<ul style="list-style-type: none"> • Yes, go to Step 8. • No, go to Step 7a.
7a	Is there 12Vdc between the frame solenoid side post going toward the battery red wire and the black ground wire?	<ul style="list-style-type: none"> • Yes, replace the frame solenoid. • No, go to Step 7b.
7b	Is there 12Vdc between the circuit breaker post going toward the frame solenoid red wire and the battery tray black ground cable? (Circuit breaker is located under the battery tray.)	<ul style="list-style-type: none"> • Yes, check between these two points for a broken wire or poor wire crimp. • No, go to Step 7c.
7c	Is there 12Vdc between the circuit breaker post going toward the battery red wire and the battery tray black ground cable?	<ul style="list-style-type: none"> • Yes, wait 15 seconds and repeat Step 7b. • Still No, on Step 7b replace the circuit breaker. • No, go to Step 7d.
7d	Is there 12Vdc between the battery small red wire and the battery post negative?	<ul style="list-style-type: none"> • Yes, check between these two points for a broken wire or poor wire crimp. • No, go to Step 7e.

Chapter 8 Troubleshooting

Table 8-2 Burner Electrical Troubleshooting (continued)

Step	Possible Cause	If . . .
7e	Is there 12Vdc between the battery post positive and the battery post negative?	<ul style="list-style-type: none"> • Yes, check between small red wire and the circuit breaker for a broken wire or poor wire crimp. • No, replace the battery.
8	Remove the six pin plug from the burner. Is there 12Vdc between the red wire and black ground wire?	<ul style="list-style-type: none"> • Yes, go to Step 9. • No, check for a broken wire or poor wire crimp on both wires.
9	Is there 12Vdc between the white wire and the black ground wire?	<ul style="list-style-type: none"> • Yes, go to Step 10. • No, check for a broken wire or poor wire crimp on the white wire.
10	Plug the six pin plug back onto the burner, loosen the two screws holding the DC Controller in place and set it to the side with all the wires connected. Is there 12Vdc between the red wire and black ground wire inside the gang box?	<ul style="list-style-type: none"> • Yes, go to Step 11. • No, check for a broken wire or poor wire crimp on both wires.
11	Is there 12Vdc between the white wire and black ground wire inside the gang box?	<ul style="list-style-type: none"> • Yes, go to Step 12. • No, check for a broken wire or poor wire crimp on the white wire.
12	Remove the six pin plug from the burner, remove the wire nuts between the two white wires, two red wires and the two black ground wires, then reconnect these six wires white to white, red to red and black to black, reconnect the burner plug. Is there 12Vdc between the red wire and the black ground wire? (Checking the underside of the wire nuts.)	<ul style="list-style-type: none"> • Yes, go to Step 13. • No, call Crafco, Inc. and speak to a customer service technician
13	Is there 12Vdc between the white wire and the black ground wire? (Checking the underside of the wire nuts.)	<ul style="list-style-type: none"> • Yes, go to Table 8-3 Testing the DC Controller • No, call Crafco, Inc. and speak to a customer service technician.

Chapter 8 Troubleshooting

8.3 Testing the DC Controller

Table 8-3 Testing the DC Controller

Step	Bench Test DC Controller
1	Remove all wire nuts attaching the DC Controller to the burner.
2	Attach the black ground wire to the negative battery post.
3	Attach the red wire to the positive battery post.
4	Attach the white (Enable) wire to the positive battery post to start the test. (Genesis II Controllers will have a 15-second delay.) <ul style="list-style-type: none"> • Orange (Blower Motor) wire should have 12Vdc (all the time). • Blue (Igniter) wire should have 12Vdc. • Purple (Fuel Solenoid) wire should have 12Vdc (after the delay).
5	Twist the yellow wires together (once voltage registers) on the orange, blue and purple wires. <ul style="list-style-type: none"> • Orange (Blower Motor) wire should maintain 12Vdc. • Blue (Igniter) wire should lose voltage after 15 seconds. • Purple (Fuel Solenoid) wire should maintain 12Vdc.
6	If any of the above tests fails, replace the DC Controller.

8.4 Burner Troubleshooting

Table 8-4 Burner Troubleshooting

Step	Burner Troubleshooting
1	Remove cord set from fuel solenoid.
2	Check the ohms between the terminals of fuel solenoid.
3	If the reading is between 15-25 ohms the coil is good.
4	If the reading is outside the above range or the meter indicates an open circuit, replace the fuel solenoid.

Chapter 8 Troubleshooting

8.5 Ignition Coil Troubleshooting

Table 8-5 Ignition Coil Troubleshooting

Step	Ignition Coil Test
1	Make sure the burner is off.
2	Check resistance between each of the springs and the ground (exposed metal on the burner).
3	The meter should read less than 2000 ohms. (Take note of the readings, you will use them in Step 5.)
4	Check resistance between both springs. (Take note of the reading, you will use it in Step 5.)
5	The igniter should be replaced if: <ul style="list-style-type: none"> • The difference between the two springs to ground resistance reading is greater than 20%. • Or the spring-to-spring resistance does not read approximately twice the spring to ground.

8.6 Bleeding the Diesel Burner

Table 8-6 Bleeding the Diesel Burner

Step	Bleeding the Diesel Burner
1	Place an oil pan under the machine in front of the burner.
2	Using a 3/8" wrench, loosen the bleeder valve on the fuel pump. Refer to Figure 8.3 Diesel Burner Air Settings .
3	Turn the ignition key to the "ON" position, then turn the power toggle switch to the "ON" position. Fuel should flow out of the bleeder valve. You want the fuel to be clear from any air bubbles; this may require you to turn the ignition key "OFF" and "ON" a couple of times.
4	Allow burner to cycle itself off 30 seconds.
5	Tighten the bleeder valve.

Chapter 8 Troubleshooting

8.7 Smoke Coming Out of the Exhaust Stack

Table 8-7 Smoke Coming Out of the Exhaust Stack

Step	Smoke Coming Out of the Exhaust Stack
1	White smoke indicates that there is too much air being forced through the burner. Loosen the Air Shutter screw and rotate the Air Shutter clockwise to increase air and counter clockwise to reduce air. Refer to Figure 8.3 Diesel Burner Air Settings , for the proper air settings and diagram.
2	Black smoke indicates that there is too much fuel being forced through the burner nozzle or there is not enough air being forced through the burner. First check the battery voltage, then move to the air settings, then move to the electrode assembly.
3	Using a 7/16" wrench, remove the copper fuel line nut attached to the nozzle line. Refer to Figure 8.2 Diesel Burner Electrode Adjustment . Next remove the locking nut for the nozzle tube. Then loosen the locking tabs on the ignition coil and open the ignition coil. Remove the nozzle line assembly.
4	Using Figure 8.2 Diesel Burner Electrode Adjustment , make sure the electrodes are in the correct position. Loosen the clamp holding the electrodes in place so they can be adjusted. Inspect the porcelain ceramic insulator for any cracks. Also check the tip of each of the electrodes to make sure they still have a sharp point and are not rounded off.
5	If it has been longer than 500 hours since the last time the burner nozzle was replaced, CrafcO recommends replacing the burner nozzle at this time.
6	Reassemble the burner, using the reverse order in Step 3.
7	Remove the burner assembly by removing the four (4) 3/8" nuts holding the burner to the burner box.
8	Using an inspection mirror, make sure the insulation inside the burner box is not soaked with diesel fuel.
9	If the insulation is soaked with diesel fuel, you will need to remove the front face of the burner box and replace the insulation.
10	Reassemble the burner box and burner.

Chapter 8 Troubleshooting

8.8 Burner Electrode Adjustment

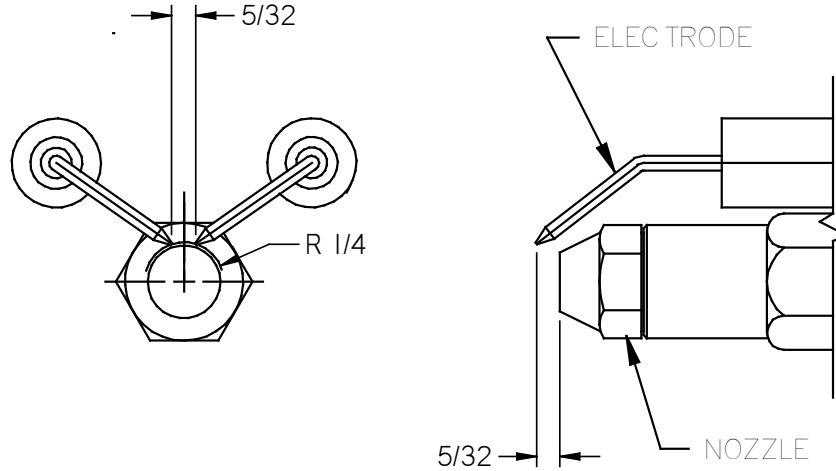

Figure 8-2 Diesel Burner Electrode Adjustment

8.9 Burner Air Settings

Table 8-8 Burner Air Settings

	Main Burner Settings	Tool Box Burner Settings
Air Shutter	8	4
Air Band	2	0
Fuel Pressure	140 PSI	140 PSI

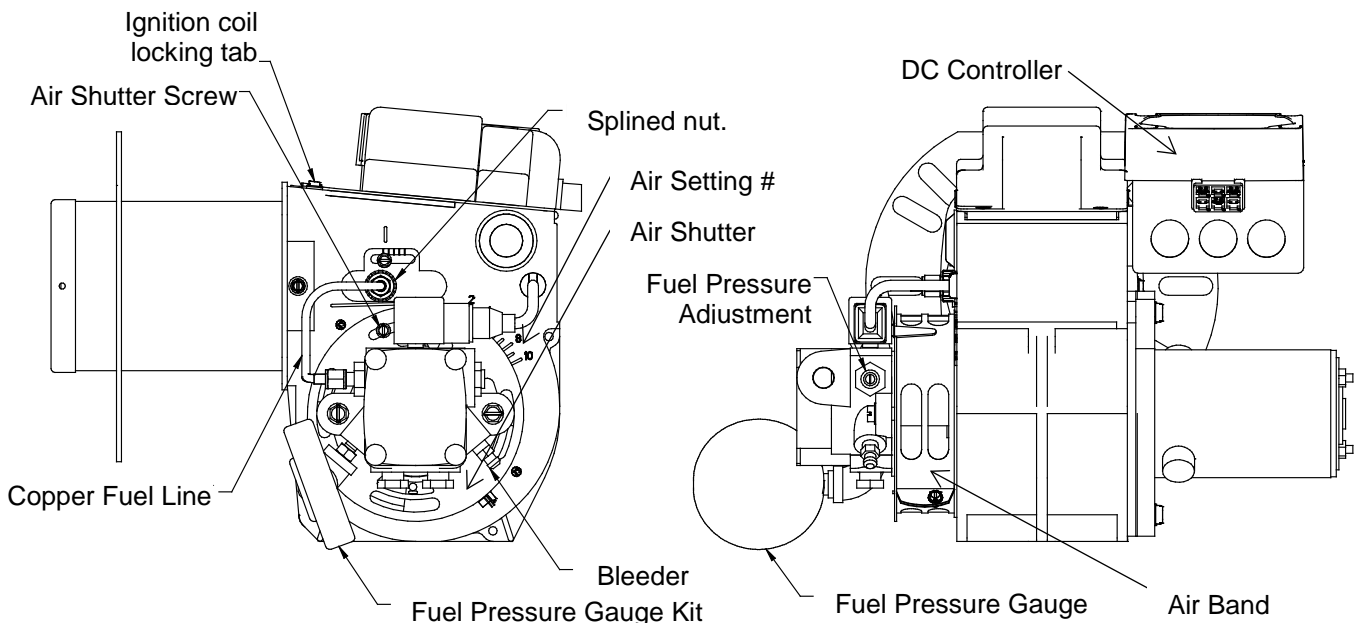

Figure 8-3 Diesel Burner Air Settings

Chapter 8 Troubleshooting

8.10 Material is Heating Slowly

Table 8-9 Material is Heating Slowly

Step	Material is Heating Slowly
1	With the material level half or less, open the loading lid and inspect the inside edge of the material tank. Check if there is a buildup of old, dried out and hardened material along the top half of the material tank.
2	If this is the case you will need to drain out (use up) the rest of the material inside the tank. When the tank is empty, use an air chisel to remove this built up material. Remove as much as possible all around the tank including the roof of the material tank. Remove all the old material chunks from the bottom of the material tank. This should be done every 500 hours or as conditions require.
3	Check your level of the heat transfer oil, the mark on the dipstick is for 70°F.
4	Check your records of the last service replacement of the heat transfer oil. If it has been longer than 500 hours, or one year, you need to change your oil.
5	Many of Crafcoc, Inc. service centers can perform these service steps for you if you cannot. Call your local service center to learn more.

8.11 Mixer Troubleshooting

8.11.1 Symptom: Mixer Does Not Rotate

Table 8-10 Mixer Basic Visual Troubleshooting

Step	Possible Cause	If . . .
1	Start Troubleshooting at the control box. Is the Mixer Control Switch Up or Down?	<ul style="list-style-type: none"> • Yes, go to Step 2. • No, flip switch to desired rotation.
2	Is the loading door closed?	<ul style="list-style-type: none"> • Yes, go to Step 3. • No, shut the loading door.
3	Is the "Mixer Control" toggle switch in the "Clockwise" position?	<ul style="list-style-type: none"> • Yes, go to Step 4. • No, move the toggle switch to the Clockwise position.
4	Move the "Mixer Control" toggle switch to the "C'Clockwise" position. Is the agitator moving?	<ul style="list-style-type: none"> • Yes, Go to Step 5. • No, go to Table 8-12 Mixer Electrical Troubleshooting

Chapter 8 Troubleshooting

Table 8-11 Mixer Basic Visual Troubleshooting (continued)

Step	Possible Cause	If . . .
5	Open the Material loading door. Are there more than six (6) unmelted blocks in the tank?	<ul style="list-style-type: none"> • Yes, this can cause the agitator to jam. Use the mixer toggle switch to move the agitator forward and backward until the material melts enough to allow forward movement without jamming. • No, go to Table 8-12 Mixer Electrical Troubleshooting.
6	Is the hydraulic fluid level near the center of the sight gauge or higher?	<ul style="list-style-type: none"> • Yes, go to Step 7. • No, fill oil to the center of the sight gauge.
7	Is the hydraulic pressure too low?	<ul style="list-style-type: none"> • Yes, reset pressure. See Table 8-15 Mixer Hydraulic Troubleshooting Step 3. • No, go to Table 8-12 Mixer Electrical Troubleshooting

Table 8-12 Mixer Electrical Troubleshooting

Step	Possible Cause	If . . .
1	Does the lid make full contact with the switch?	<ul style="list-style-type: none"> • Yes, go to Step 1a. • No, adjust the switch location so the lid activates the switch.
1a	Does the lid switch make continuity when it is fully depressed? Use an Amp meter set to continuity and check both studs on the switch.	<ul style="list-style-type: none"> • Yes go to Step 2. • No, the lid switch is bad. Replace the switch.
2	Is there 12Vdc between the lid switch red wire and a nearby ground source? (Check both red and green wires on the bottom of the lid switch with the lid closed.)	<ul style="list-style-type: none"> • Yes, on both wires go to Step 3. • Yes, on only one red wire when the lid is closed. Readjust the lid switch so that the lid completely depresses the switch, and then recheck for 12Vdc. If the same result happens, replace the lid switch. • No, check for a blown fuse, broken wire or poor wire crimp between the lid switch and the engine ignition switch.
3	Is there continuity between the green wire on the lid switch and the green wire on the mixer switch?	<ul style="list-style-type: none"> • Yes, go to step 4. • No, check for a broken wire or poor wire crimp on the green wire and terminals.

Chapter 8 Troubleshooting

Table 8-13 Mixer Electrical Troubleshooting (continued)

Step	Possible Cause	If . . .
4	Is there 12Vdc between the "Mixer" toggle switch center post green wire and the main black ground wires?	<ul style="list-style-type: none"> • Yes, go to Step 5. • No, check for a broken wire or poor wire crimp between the "Mixer" toggle switch and the lid switch.
5	Is there 12Vdc between the "Mixer" toggle switch bottom post pink wire and the main black ground wires? (With the "Mixer" toggle switch in the "Clockwise" position.)	<ul style="list-style-type: none"> • Yes, go to Step 6. • No, replace the "Mixer" toggle switch.
6	Is the din plug light "ON" when the "Mixer" is in the "Clockwise" position? (Looking down at the top of the hydraulic valve, Mixer up is the din plug marked Clockwise.) (Refer to Figure 8.6 Din Plug Layout .)	<ul style="list-style-type: none"> • Yes, go to Step 7. • No, replace the din plug.
7	Unscrew the din plug center screw so you can pull the din plug up about 1/4" in order to check for voltage. Is there 12Vdc from side post to side post? (Refer to Figure 8.4 Checking Din Plug Voltage)	<ul style="list-style-type: none"> • Yes, the electrical system for the mixer is working properly, go to Table 8-15 Mixer Hydraulic Troubleshooting. • No, recheck the amber light, if the light comes "ON" and you do not have 12Vdc then replace the din plug.
8	Clockwise mixing works but C'Clockwise does not.	<ul style="list-style-type: none"> • Yes, go to Step 9.
9	Is there 12Vdc between the "Mixer" toggle switch top post purple wire and the main black ground wires? (With the "Mixer" toggle switch in the "C'Clockwise" position.)	<ul style="list-style-type: none"> • Yes, go to Step 10. • No, replace the "Mixer" toggle switch.

Chapter 8 Troubleshooting

Table 8-14 Mixer Electrical Troubleshooting (continued)

Step	Possible Cause	If . . .
10	<p>Is the din plug light "ON" when the "Mixer" is in the "C'Clockwise" position?</p> <p>(Looking down at the top of the hydraulic valve, Mixer down is the din plug marked Counter-Clockwise.) (Refer to Figure 8.6 Din Plug Layout).</p>	<ul style="list-style-type: none"> • Yes, go to Step 11. • No, replace the din plug.
11	<p>Unscrew the din plug center screw so you can pull the din plug up about 1/4", so you can check for voltage.</p> <p>Is there 12Vdc from side post to side post? (Refer to Figure 8.4 Checking Din Plug Voltage)</p>	<ul style="list-style-type: none"> • Yes, the electrical system for the mixer is working properly, go to Table 8-15 Mixer Hydraulic Troubleshooting. • No, recheck the din plug light, if the light comes "ON" and you do not have 12Vdc then replace the din plug.



Figure 8-4 Checking Din Plug Voltage

Chapter 8 Troubleshooting

8.12 Mixer Hydraulic Troubleshooting

Table 8-15 Mixer Hydraulic Troubleshooting

Step	Possible Cause	If . . .
1	Does the coil magnetize when the din plug amber light is "ON"?	<ul style="list-style-type: none"> • Yes, go to Step 2. • No, remove the din plug, then remove the coil by unscrewing the nut on the end of the coil. With the coil removed, re-attach the din and place a metal screwdriver in the center of the coil and move it toward the side of the coil to see if the coil is magnetic. If it is not, recheck the din plug is plugged into the coil and the amber light is "ON". If still not magnetic, replace the coil.
2	Is the relief pressure set correctly? (Refer to Figure 8.5 Hydraulic Pressure Adjustment Location for pressure settings.)	<ul style="list-style-type: none"> • Yes, go to Step 3. • No, first turn "OFF" the engine, then remove one of the two hydraulic hoses going to the agitator hydraulic motor, cap off the fitting on the motor and use a 3,000 PSI gauge with the proper JIC fitting, attach it to the hose. Start the engine, turn "ON" the main power in the control box, move the "Mixer" toggle switch to the "Clockwise" position and read the pressure gauge. If the pressure needs to be adjusted, use the pressure relief valve labeled "RVA", loosen the jam nut and adjust the pressure with the allen screw at the end of the relief. Turn clockwise to increase pressure and counter clockwise to reduce pressure, then tighten the jam nut to lock the pressure. Next turn "OFF" the engine, remove the cap, pressure gauge and reattach the hose.
3	Is the hydraulic flow correct from the hydraulic pump?	<ul style="list-style-type: none"> • Yes, call Crafco, Inc. and speak to customer service. • No, call a local hydraulic shop to see if they can run a hydraulic pump flow test, using the information in Figure 8.5 Hydraulic Pressure Adjustment Location

Chapter 8 Troubleshooting

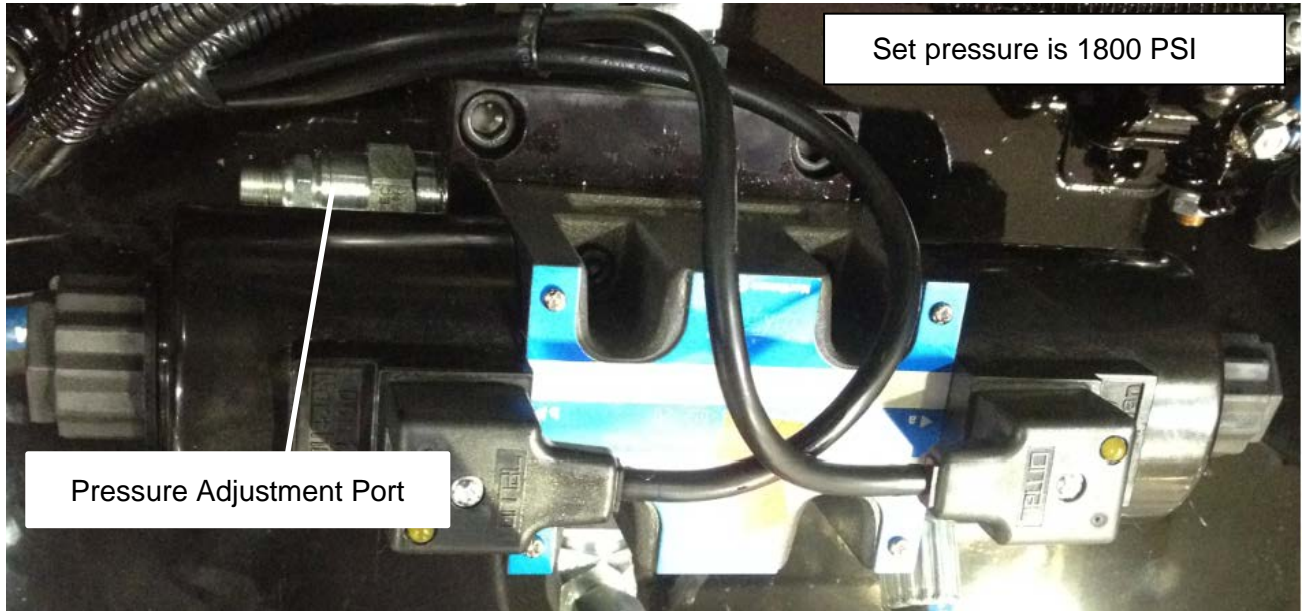

Figure 8-5 Hydraulic Pressure Adjustment Location

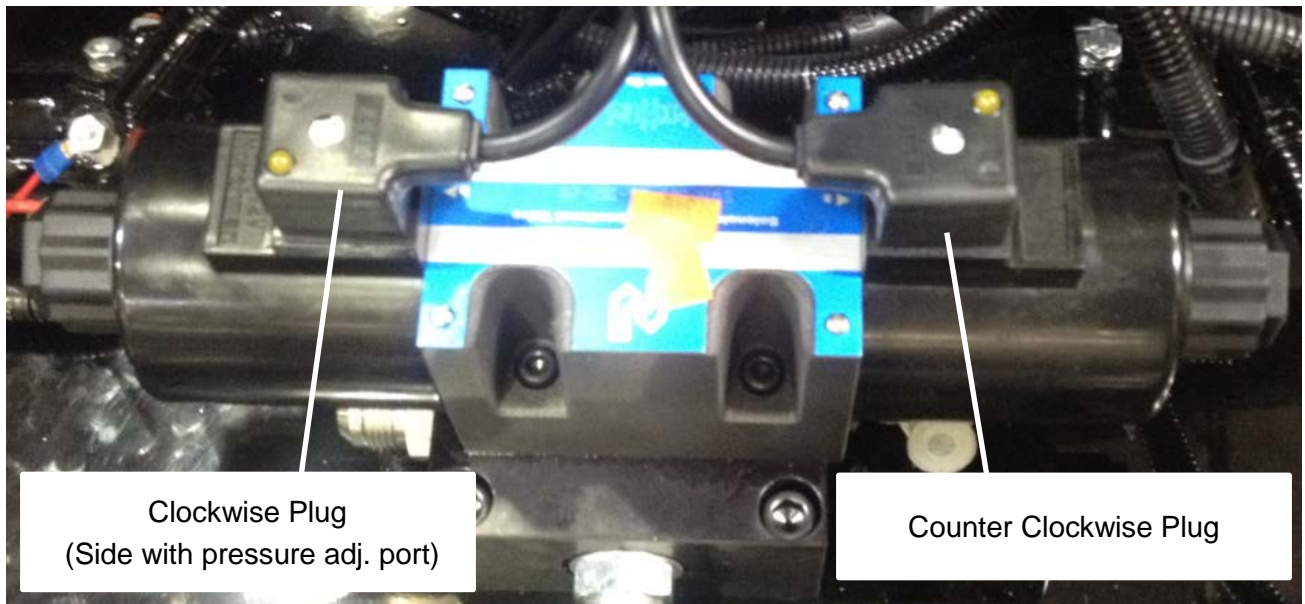

Figure 8-6 Din Plug Layout

Chapter 8 Troubleshooting

8.13 Hydraulic Schematic

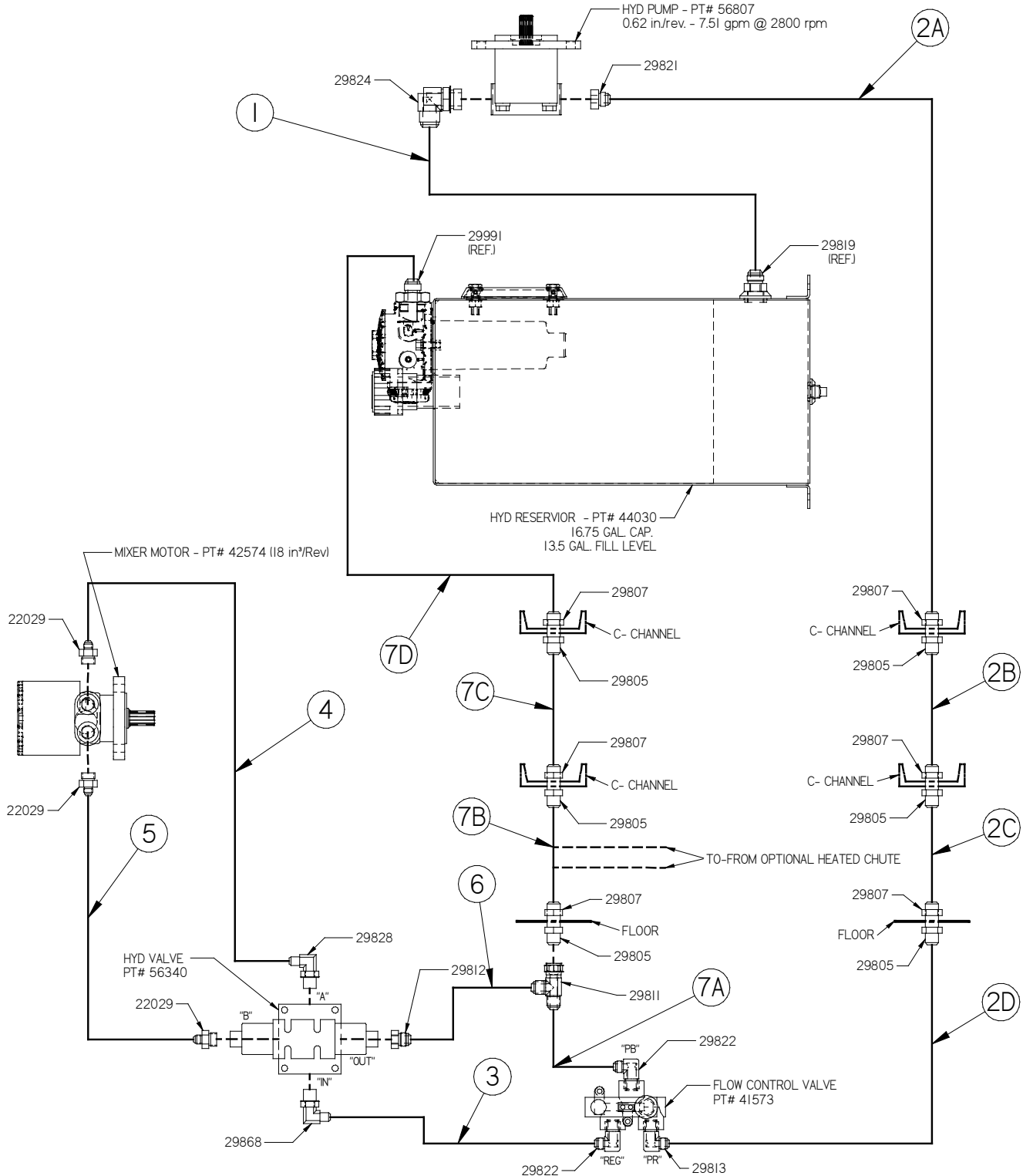

Figure 8-7 Hydraulic Schematic (P/N 26589)

Chapter 8 Troubleshooting

8.14 RTD Sensor Ohms vs. Temperature

Table 8.15 below shows what the ohm reading should be for a given temperature. The following are the instructions for using the table.

1. Measure the resistance (ohms) of the sensor in question with an ohm meter.
2. Find the reading in the chart (columns 0 through 9).
3. Follow the row to the left and get the temperature in 10°F increments, then follow the column up to get the 1°F increment. (For example, 1391 Ohms = 215°F)

Table 8-16 RTD Sensor Ohms vs. Temperature

°F	0	1	2	3	4	5	6	7	8	9
0	930.3	932.5	934.7	936.9	939.1	941.3	943.4	945.6	947.8	950.0
10	952.2	954.3	956.5	958.7	960.9	963.0	965.2	967.4	969.6	971.8
20	973.9	976.1	978.3	980.5	982.6	984.8	987.0	989.1	991.3	993.5
30	995.7	997.8	1000.0	1002.2	1004.3	1006.5	1008.7	1010.9	1013.0	1015.2
40	1017.4	1019.5	1021.7	1023.9	1026.0	1028.2	1030.4	1032.5	1034.7	1036.9
50	1039.0	1041.2	1043.4	1045.5	1047.7	1049.8	1052.0	1054.2	1056.3	1058.5
60	1060.7	1062.8	1065.0	1067.1	1069.3	1071.5	1073.6	1075.8	1077.9	1080.1
70	1082.2	1084.4	1086.6	1088.7	1090.9	1093.0	1095.2	1097.3	1099.5	1101.6
80	1103.8	1106.0	1108.1	1110.3	1112.4	1114.6	1116.7	1118.9	1121.0	1123.2
90	1125.3	1127.5	1129.6	1131.8	1133.9	1136.1	1138.2	1140.4	1142.5	1144.7
100	1146.8	1149.0	1151.1	1153.2	1155.4	1157.5	1159.7	1161.8	1164.0	1166.1
110	1168.3	1170.4	1172.5	1174.7	1176.9	1179.0	1181.1	1183.3	1185.4	1187.5
120	1189.7	1191.8	1194.0	1196.1	1198.2	1200.4	1202.5	1204.6	1206.8	1208.9
130	1211.0	1213.2	1215.3	1217.5	1219.6	1221.7	1223.9	1226.0	1228.1	1230.3
140	1232.4	1234.5	1236.7	1238.9	1240.9	1243.0	1245.2	1247.3	1249.4	1251.6
150	1253.7	1255.8	1258.0	1260.1	1262.2	1264.3	1266.5	1268.6	1270.7	1272.8
160	1275.0	1277.1	1279.2	1281.3	1283.5	1285.6	1287.7	1289.8	1292.0	1294.1
170	1296.2	1298.3	1300.4	1302.6	1304.7	1306.8	1308.9	1311.0	1313.2	1315.3
180	1317.4	1319.5	1321.6	1323.8	1325.9	1328.0	1330.1	1332.2	1334.3	1336.5
190	1338.6	1340.7	1342.8	1344.9	1347.0	1349.1	1351.2	1353.4	1355.5	1357.6
200	1359.7	1361.8	1363.9	1366.0	1368.1	1370.2	1372.4	1374.5	1376.6	1378.7
210	1380.8	1382.9	1385.0	1387.1	1389.2	1391.3	1393.4	1395.5	1397.6	1399.7
220	1401.8	1403.9	1406.0	1408.1	1410.3	1412.4	1414.5	1416.6	1418.7	1420.8
230	1422.9	1425.0	1427.1	1429.2	1431.3	1433.4	1435.5	1437.6	1439.6	1441.7
240	1443.8	1445.9	1448.0	1450.1	1452.2	1454.3	1456.4	1458.5	1460.6	1462.7
250	1464.8	1466.9	1469.0	1471.1	1473.2	1475.3	1477.3	1479.4	1481.5	1483.6
260	1485.7	1487.8	1489.9	1492.0	1494.1	1496.1	1498.2	1500.3	1502.4	1504.5

Chapter 8 Troubleshooting

Table 8-15.1 RTD Sensor Ohms vs. Temperature (continued)

°F	0	1	2	3	4	5	6	7	8	9
270	1506.6	1508.7	1510.8	1512.8	1514.9	1517.0	1519.1	1521.2	1523.3	1525.3
280	1527.4	1529.5	1531.6	1533.7	1535.7	1537.8	1539.9	1542.0	1544.1	1546.1
290	1548.2	1550.3	1552.4	1554.5	1556.5	1558.6	1560.7	1562.8	1564.8	1566.9
300	1569.0	1571.1	1573.1	1575.2	1577.3	1579.4	1581.4	1583.5	1585.6	1587.7
310	1589.7	1591.8	1593.9	1595.9	1598.0	1600.1	1602.2	1604.2	1606.3	1608.4
320	1610.4	1612.5	1614.6	1616.6	1618.7	1620.8	1622.8	1624.9	1627.0	1629.0
330	1631.1	1633.2	1635.2	1637.3	1639.3	1641.4	1643.5	1645.5	1647.6	1649.7
340	1651.7	1653.8	1655.8	1657.9	1660.0	1662.0	1664.1	1666.1	1668.2	1670.2
350	1672.3	1674.4	1676.4	1678.5	1680.5	1682.6	1684.6	1686.7	1688.7	1690.8
360	1692.9	1694.9	1697.0	1699.0	1701.1	1703.1	1705.2	1707.2	1709.3	1711.3
370	1713.4	1715.4	1717.5	1719.5	1721.6	1723.6	1725.7	1727.7	1729.8	1731.8
380	1733.9	1735.9	1737.9	1740.0	1742.0	1744.1	1746.1	1748.2	1750.2	1752.3
390	1754.3	1756.3	1758.4	1760.4	1762.5	1764.5	1766.6	1768.6	1770.6	1772.7
400	1774.7	1776.8	1778.8	1780.8	1782.9	1784.9	1786.9	1789.0	1791.0	1793.1
410	1795.1	1797.1	1799.2	1801.2	1803.2	1805.3	1807.3	1809.3	1811.4	1813.4
420	1815.4	1817.5	1819.5	1821.5	1823.6	1825.6	1827.6	1829.6	1831.7	1833.7
430	1835.7	1837.8	1839.8	1841.8	1843.8	1845.9	1847.9	1849.9	1851.9	1854.0
440	1856.0	1858.0	1860.0	1862.1	1864.1	1866.1	1868.1	1870.2	1872.2	1874.2
450	1876.2	1878.2	1880.3	1882.3	1884.3	1886.3	1888.3	1890.4	1892.4	1894.4
460	1896.4	1898.4	1900.5	1902.5	1904.5	1906.5	1908.5	1910.5	1912.6	1914.6
470	1916.6	1918.6	1920.6	1922.6	1924.6	1926.6	1928.7	1930.7	1932.7	1934.7
480	1936.7	1938.7	1940.7	1942.7	1944.7	1946.8	1948.8	1950.8	1952.8	1954.8
490	1956.8	1958.8	1960.8	1962.8	1964.8	1966.8	1968.8	1970.8	1972.8	1974.8
500	1976.8	1978.8	1980.8	1982.9	1984.9	1986.9	1988.9	1990.9	1992.9	1994.9
510	1996.9	1998.9	2000.9	2002.9	2004.9	2006.9	2008.8	2010.8	2012.8	2014.8
520	2016.8	2018.8	2020.8	2022.8	2024.8	2026.8	2028.8	2030.8	2032.8	2034.8
530	2036.8	2038.8	2040.8	2042.8	2044.7	2046.7	2048.7	2050.7	2052.7	2054.7
540	2056.7	2058.7	2060.7	2062.7	2064.6	2066.6	2068.6	2070.6	2072.6	2074.6
550	2076.6	2078.5	2080.5	2082.5	2084.5	2086.5	2088.5	2090.4	2092.4	2094.4

Chapter 9 Illustrated Parts List

9.0 About the Illustrated Parts List

The Illustrated Parts List (IPL) is designed to help technical service or maintenance personnel correctly identify orderable replacement parts.

The figure and table titles reference the part number (PN) to which they apply. The PN's for each of the Patcher II models are as follows:

Patcher II PN 56700

Illustrations and pictures are designed to show general shape and size of a part and the relationship that part has to other parts. Actual size and shape of parts or components may differ or vary from the actual part or component.

9.1 Ordering CrafcO Parts

Crafco distributors and CrafcO Pavement Preservation Supply Centers are strategically located throughout the United States. Parts can be ordered from your local CrafcO distributor or directly from CrafcO, Inc. if a distributor is not available in your area.

When ordering parts, give the following information:

- Part Number
- Machine Model
- Serial Number

Write, call, or Fax CrafcO, Inc. at the following:

Crafco, Inc. Headquarters
6165 West Detroit Street
Chandler, AZ 85226
Phone: (602) 276-0406
Toll Free: (800) 528-8242
Fax: (480) 961-0513

Visit our website at www.crafco.com

Chapter 9 Illustrated Parts List

9.2 Patcher II Parts List

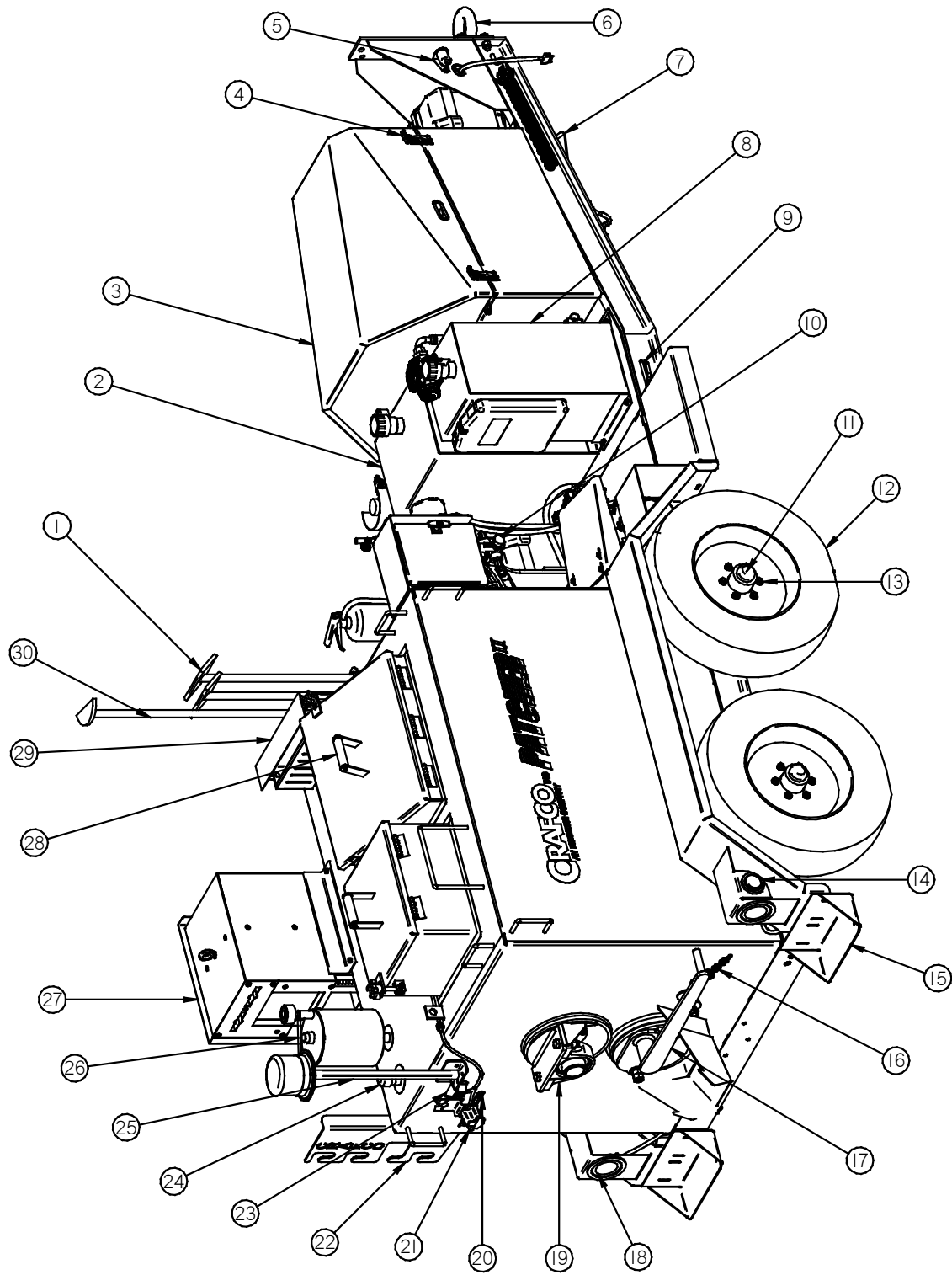

Figure 9-1 Right Iso View

Chapter 9 Illustrated Parts List

Table 9-1 Right View Parts List

FIG.	ITEM	PART NO.	DESCRIPTION	QTY
Fig. 9.1	1	32243	TECHCRETE IRONING WAND ASSY	2
	2	56880	FUEL TANK, 26GAL PATCHER II	1
	3	45535	OPTIONAL ENGINE COVER ASSY	1
	4	45600	LATCH, T HANDLE, RUBBER REPLCMNT	2
	5	23117	BREAKAWAY SWITCH UNIT	1
	6	20016	2 ½" PINTLE HITCH	1
	7	23082	5000# TONGUE JACK, 15"	1
	8	44030	HYD TANK ASSY	1
	9	32365	SIDE MARKER LIGHT	2
	10	41573	FLOW DIVIDER PRIORITY VALVE	1
	11	56763	TORSIONAL AXLE, 5200#	2
	12	42515	TIRE AND RIM ASSY	4
	13	23130	LUG NUT	24
	14	32364	RED SIDE MARKER KIT	2
	15	56706	STEP DRIVER'S SIDE FORMED	2
	16	91648	BOOM STOW SAFETY CHAIN ASSY.	1
	17	57778	GATE ASSEMBLY	1
	18	32363	RED STT LAMP KIT	1
	19	57813	BEARING, PILLOW BLOCK, 2-3/4 HI-TEMP	1
	20	26099	LICENSE PLATE HOLDER	1
	21	44797	LICENSE PLATE LIGHT	1
	22	32404	OUTER TOOL BOX ASSY HOLDER	1
	23	42796	SWITCH HOUSING	1
	23	50720	BOOT WATER TIGHT SWITCH	1
	24	28271	PIPE CAP, 1 1/4 NPT	1
	25	24095K	STROBE LIGHT KIT	1
	26	57775	HOT OIL DIPSTICK ASSY	1
	27	57450N	HEATED TOOL BOX, DIESEL FIRED	1
	28	27077	HANDLE, WOODEN	2
	29	56797	VENT COVER ASSY	1
30	32258	TANK SCRAPER ASSY	1	

Chapter 9 Illustrated Parts List

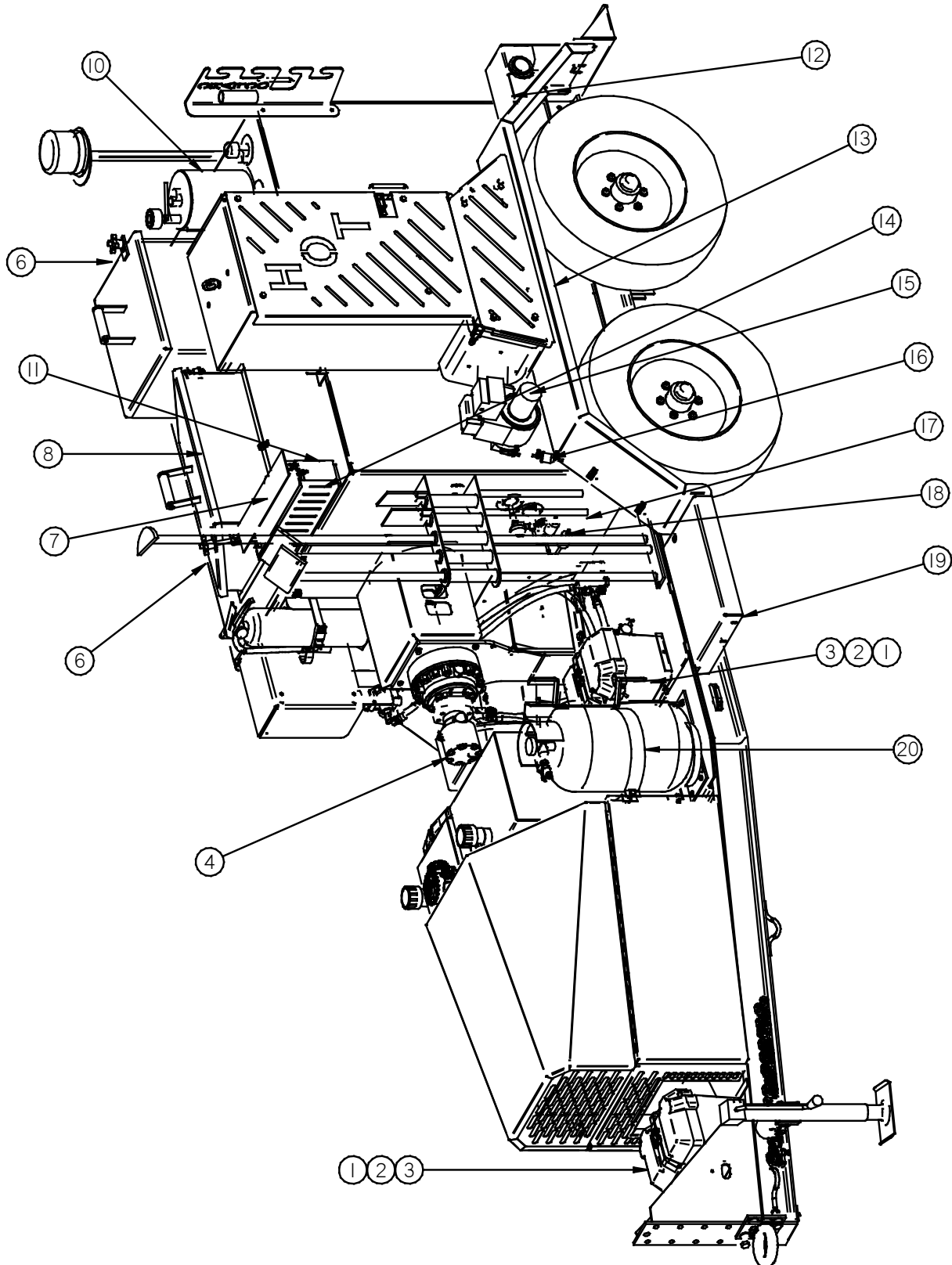

Figure 9-2 Left Iso View

Chapter 9 Illustrated Parts List

Table 9-2 Left View Parts List

FIG.	ITEM	PART NO.	DESCRIPTION	QTY
Fig. 9.2	1	24000	SEALED BATTERY 12-VOLT 24-2	2
	2	24002	BATTERY BOX	2
	3	24037	BATTERY STRAP W/BUCKLE 4'	2
	4	42574	MIXER HYDRAULIC MOTOR	1
	5	57750	DRIVE COVER	1
	6	56816	CAST IRON KNOB	2
	7	43465	RTD SENSOR	1
	8	45786	LID ASSEMBLY (SS250)	1
	9	45793	LID ASSEMBLY (SS125)	1
	NS	39608	AUTOSTOP SWITCH	1
	10	43355	OVER FLOW TANK ASSEMBLY	1
	11	57774	SHEET, VENT REAR GUARD	1
	12	57780	STEP, UPPER DRIVERS SIDE FORMED	1
	13	57852	TREAD PLATE FENDER, PATCHER II	2
	14	57773	SHEET, VENT FRONT GUARD	1
	15	57485N	HOT TOOL BOX BURNER ASSY – COMES SET UP WITH NOZZLE (PN 32403), BAFFLE (PN 32400), HEAD DIFFUSER (PN 32401)	1
	15A	46380	BURNER ASSY	1
	NS	32400	BAFFLE, BURNER (ONLY FOR TOOL BOX)	1
	NS	32401	HEAD DIFFUSER (ONLY FOR TOOL BOX)	1
	16	56932	INLINE FUEL FILTER	1
	17	32246	CHUTE SCRAPER ASSY	2
18	24190	OVERNIGHT HEATER	2	
19	56729	PLATE, FORMED PLATFORM	2	
20	57754	OPTIONAL PROPANE TORCH MOUNT	1	
21	57781	OPTIONAL COMPLETE TORCH KIT	1	

Chapter 9 Illustrated Parts List

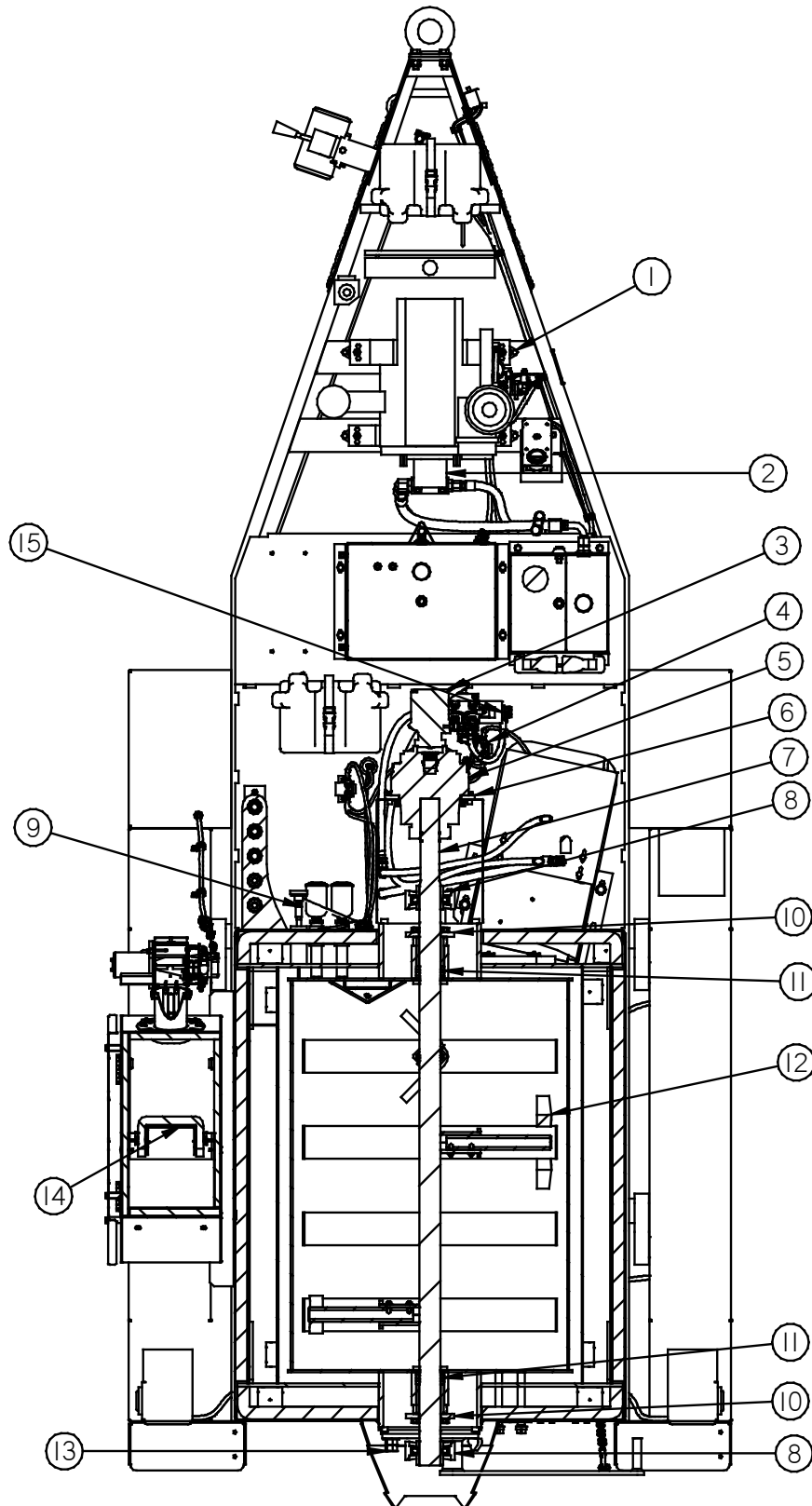

Figure 9-3 Top Section View

Chapter 9 Illustrated Parts List

Table 9-3 Top Section View Parts List

FIG.	ITEM	PART NO.	DESCRIPTION	QTY
Fig.9.3	1	29399	ISO MOUNT, 3/8-16 THRD	4
	2	56807	HYD. PUMP .5 IN/REV	1
	3	42574	MIXER MOTOR	1
	4	39602	SOLENOID, CONSTANT DUTY	2
	5	57786	6 TO 1 GEARBOX ASSY	1
	6	57748	GEAR BOX MOUNT UPPER PLATE	1
	6A	57746	GEAR BOX MOUNT MID PLATE	1
	6B	57747	GEAR BOX MOUNT BASE	1
	7	57766	MIXER MAIN SHAFT	1
	8	57813	BEARING, PILLOW BLOCK, 2-3/4 HI-	1
	9	43465	RTD SENSOR	2
	10	57792	PACKING GLAND ASSY	2
	11	32226	PACKING GLAND	8
	12	56875	PADDLE ASSY (BOLT ON)	4
	13	28624	3/4"-10 HEX NUT, HEAVY	2
	14	57475N	FUNNEL/CHUTE ASM. W/ INSUL	1
15	56340	HYDRAULIC CONTROL VALVE	1	
16	32263	BUCKET (NOT SHOWN)	2	

Chapter 9 Illustrated Parts List

9.3 Fuel and Hydraulic Tanks Parts List

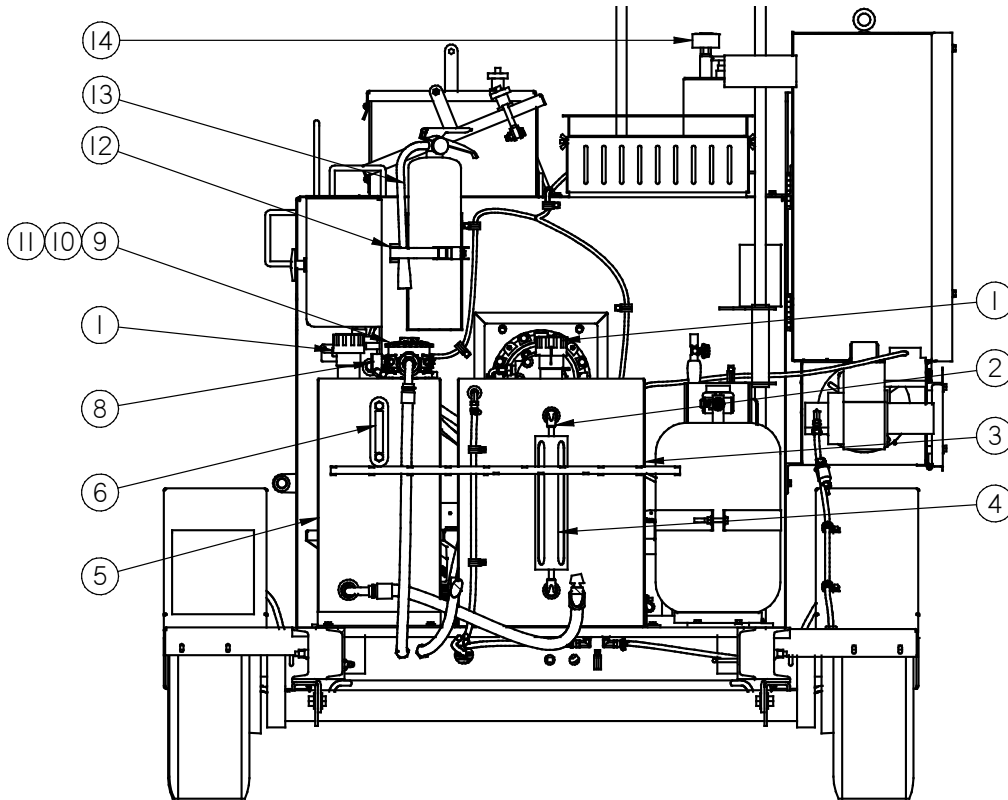

Figure 9-4 Fuel and Hydraulic Tanks Section View
Table 9-4 Fuel and Hydraulic Tanks Parts List

FIG.	ITEM	PART NO.	DESCRIPTION	QTY
Fig. 9.4	1	43579	PRESSURE FILLER BREATHER CAP	2
	2	44817	FITTING, SIGHT GLASS - DIESEL	2
	3	56880	FUEL TANK, 26 GAL, PATCHER II	1
	4	44191	½" FUEL SIGHT TUBING, (FT)	1.5
	5	44030	HYDRAULIC TANK	1
	6	45415	SIGHT GAUGE (HYD)	1
	7	45497	BASE GASKET	1
	8	45437	HYDRAULIC GAUGE	1
	9	45498	HYDRAULIC FILTER ASSEMBLY	1
	10	45438	HYDRAULIC FILTER ELEMENT	1
	11	44063	O-RING, UNDER ASSEMBLY COVER	1
	12	26059	OPTIONAL FIRE EXTINGUISHER MOUNT	1
	13	26058	OPTIONAL FIRE EXTINGUISHER	1
	14	26025	AIR BREATHER AND ELEMENT	1

Chapter 9 Illustrated Parts List

This page is left blank on purpose

Chapter 9 Illustrated Parts List

9.4 Engine Parts List

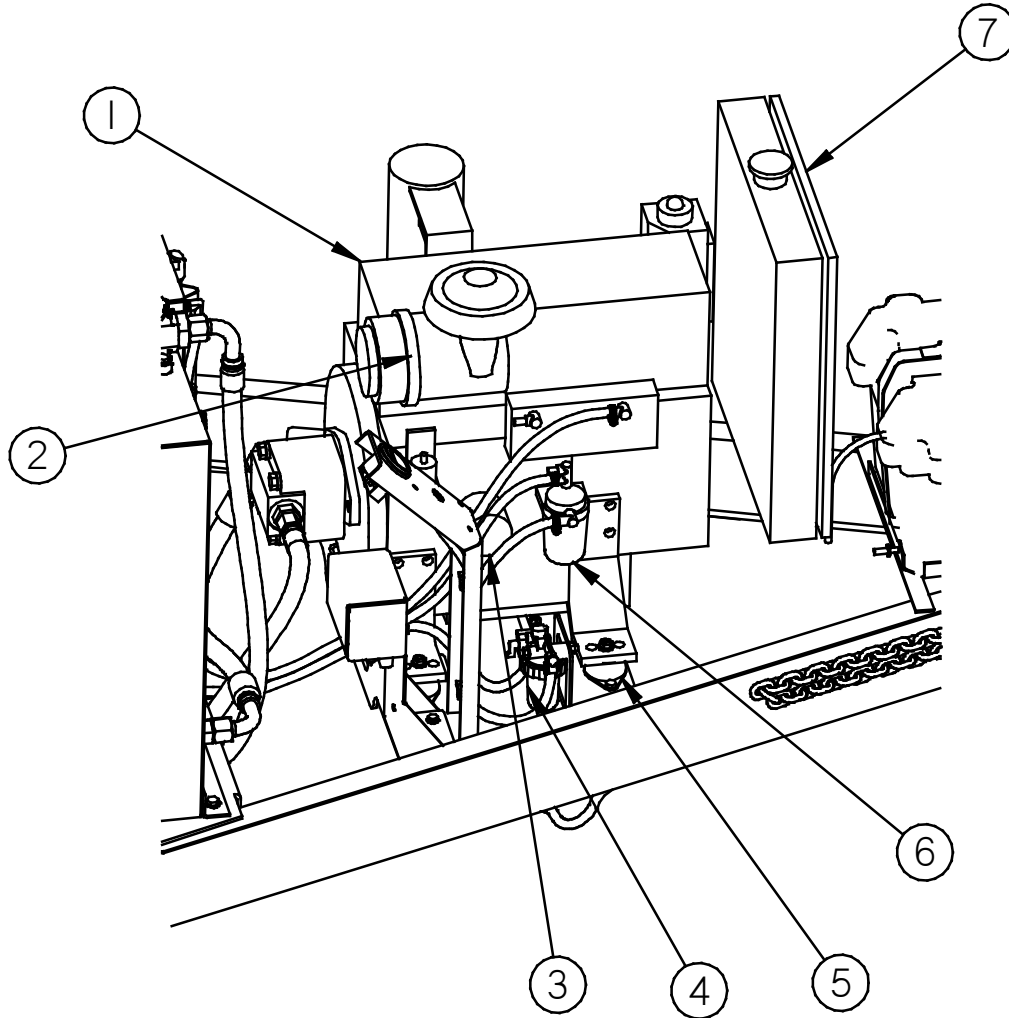

Figure 9-5 Engine

Chapter 9 Illustrated Parts List

Table 9-5 Engine Parts List

FIG.	ITEM	PART NO.	DESCRIPTION	QTY
Fig. 9.5	1	47105	ISUZU 20 HP 3CJ1 ENGINE	1
	2	45391	AIR FILTER ISUZU 3CB/3CA/3CJ ENGINE	1
	3	45389	OIL FILTER ISUZU 3CA1/3CJ1 ENGINE	1
	4	47150	WATER SEPARATOR	1
	5	29399	ISOMOUNTS	4
	6	41867	FUEL FILTER ISUZU 3CA1/3CJ1 ENGINE	1
	7	45443N	RADIATOR KIT	1
	8	45535	ENGINE COVER- OPTION (NOT SHOWN)	1
	9	46374	ENGINE COVER INSULATION KIT- OPTION (NOT SHOWN)	1
	10	47153	PARTS MANUAL ISUZU 3CJ1 ENGINE (NOT SHOWN)	1
	11	47155N	RADIATOR OVERFLOW BOTTLE KIT (NOT SHOWN)	1
	12	45444L	LOWER RADIATOR HOSE (NOT SHOWN)	1
	13	45444U	UPPER RADIATOR HOSE (NOT SHOWN)	1
	14	41872	LOWER RADIATOR ISOMOUNT (NOT SHOWN)	2
	15	47138N	UPPER RADIAOTR ISOMOUNT (NOT SHOWN)	1

Chapter 9 Illustrated Parts List

9.5 Hydraulic Schematic and Parts List

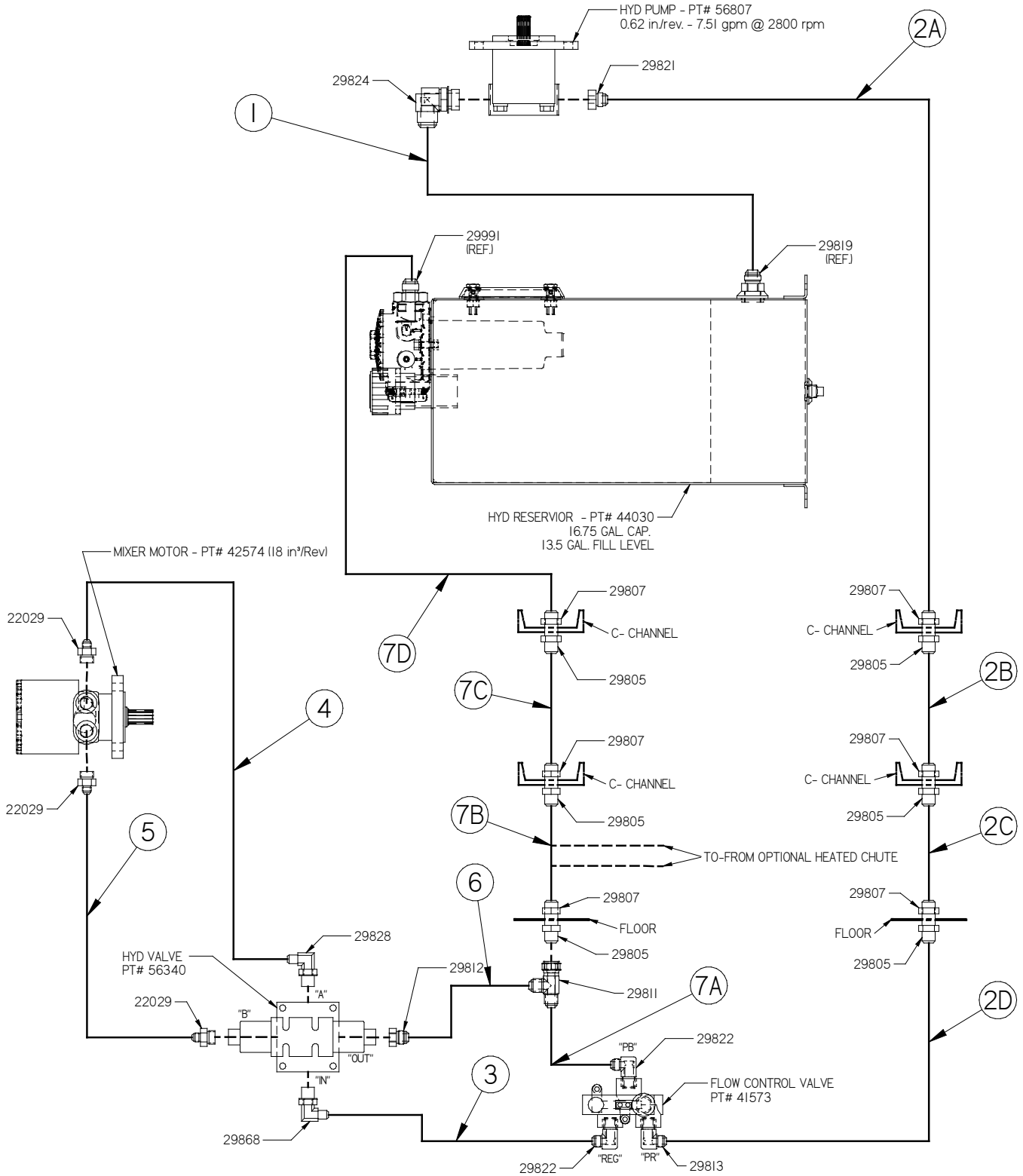

Figure 9-6 Hydraulic Schematic (P/N 26589)

Chapter 9 Illustrated Parts List

Table 9-6 Hydraulic Parts List

FIG	ITEM	PART NO.	DESCRIPTION	QTY
Fig.9.6	1. HYDRAULIC RESERVOIR TO HYDRAULIC PUMP (SUCTION)			
		29819	3/4" TUBE X 3/4" STD THRD O-RING STR	1
	1	12G4H 12G-12FJX90S 12G-16FJX 29 24.25	29" SUCTION HOSE	1
		29824	1" TUBE X 1" STD THRD. O-RING 90° ELBW	1
	2. HYDRAULIC PUMP TO FLOW CONTROL VALVE "PR" PORT			
		29821	5/8" TUBE X 3/4" STD. THRD. O-RING STR	1
	2A	10M3K 10G-10FJX 10G-10FJX 28 24.5	HYD HOSE X 28" LONG	1
		29805	5/8" TUBE BULKHEAD FITTING	1
		29807	7/8-14 BULKHEAD LOCKNUT	1
	2B	10M3K 10G-10FJX90S 10G-10FJX 20.75 17	HYD HOSE X 20 3/4" LONG	1
		29805	5/8" TUBE BULKHEAD FITTING	1
		29807	7/8-14 BULKHEAD LOCKNUT	1
	2C	10M3K 10G-10FJX90S 10G-10FJX 25.25 21	HYD HOSE X 25 1/4" LONG	1
		29805	5/8" TUBE BULKHEAD FITTING	1
		29807	7/8-14 BULKHEAD LOCKNUT	1
	2D	10M3K 10G-10FJX 10G-10FJX 33.5 30	HYD HOSE X 33 1/2" LONG	1
		29813	5/8" TUBE X 3/4" NPT 90° ELBOW	1
	3. FLOW CONTROL VALVE "REG" PORT TO HYD VALVE INLET "IN"			
		29822	1/2" TUBE X 3/4" NPT 90° ELBOW	1
	3	8M3K 8G-8FJX 8G-8FJX 65.5 62.25	HYD HOSE X 65 1/2" LONG	1
		29868	1/2" TUBE X 5/8" STD. THRD. O-RING 90°	1
	4. HYD VALVE PORT "A" TO BOTTOM MOTOR PORT			
		29828	3/8" TUBE X 5/8" STD. THRD. O-RING 90°	1
	4	6M3K 6G-6FJX90S 6G-6FJX 21.5 17.75	HYD HOSE X 21.5" LONG	1
		22029	3/8" TUBE X 5/8" STD. THRD. O-RING STR	1
	5. TOP MOTOR PORT TO HYD VALVE PORT "B"			
		22029	3/8" TUBE X 5/8" STD. THRD. O-RING STR	1
	5	6M3K 6G-6FJX90L 6G-6FJX90S 27.5 23.25	HYD HOSE X 27 1/2" LONG	1
	22029	3/8" TUBE X 5/8" STD. THRD. O-RING STR	1	

Chapter 9 Illustrated Parts List

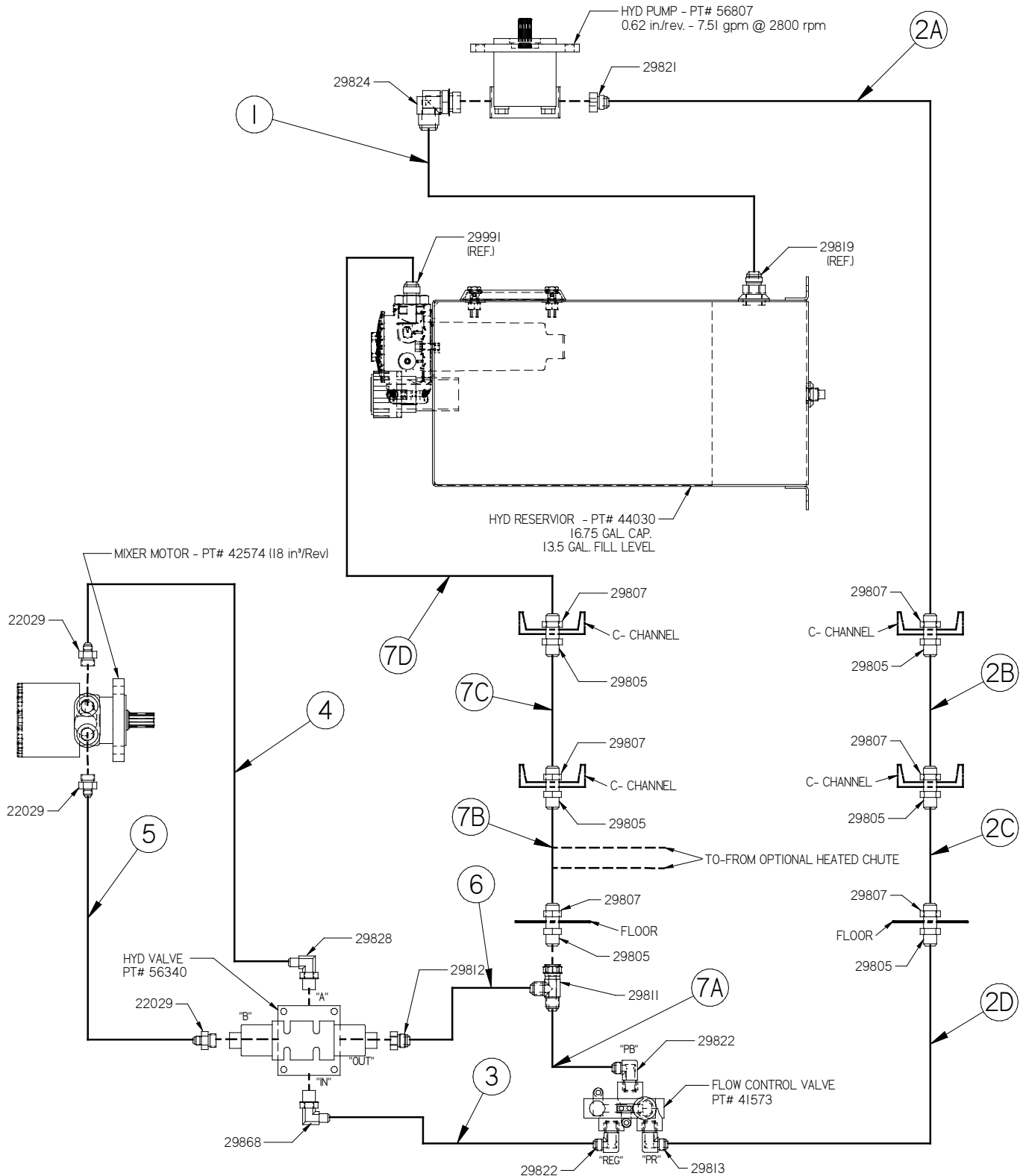

Figure 9-7 Hydraulic Schematic (PN 26589) (continued)

Chapter 9 Illustrated Parts List

Table 9-7 Hydraulic Parts List (continued)

FIG	ITEM	PART NO.	DESCRIPTION	QTY
Fig. 9.7	6. HYDRAULIC VALVE "OUT" PORT TO "T" RETURN LINE			
		29812	5/8" TUBE X 5/8" STD. THRD. O-RING STR	1
	6	8M3K 8G-10FJX 8G-10FJX 24 21.5	HYD HOSE X 24" LONG	1
	7. FLOW CONTROL VALVE "PB" PORT TO HYD RESERVOIR RETURN PORT			
		29822	1/2" TUBE X 3/4" NPT 90° ELBOW	1
	7A	8M3K 8G-8FJX 8G-10FJX 33 29.75	HYD HOSE X 33" LONG	1
		29811	5/8" TUBE X 5/8" TUBE SWIVEL NUT RUN T	1
		29805	5/8" TUBE BULKHEAD FITTING	1
		29807	7/8-14 BULKHEAD LOCKNUT	1
	7B	10M3K 10G-10FJX90S 10G-10FJX 22.25 18.5	HYD HOSE X 22 1/4" LONG	1
		29805	5/8" TUBE BULKHEAD FITTING	1
		29807	7/8-14 BULKHEAD LOCKNUT	1
	7C	10M3K 10G-10FJX90L 10G-10FJX 20.25 16.5	HYD HOSE X 20 1/4" LONG	1
		29805	5/8" TUBE BULKHEAD FITTING	1
		29807	7/8-14 BULKHEAD LOCKNUT	1
	7D	10M3K 10G-12FJX90S 10G-10FJX 34.5 30	HYD HOSE X 34 1/2" LONG	1
		29991	3/4" TUBE X 1 1/4" STD. THRD. O-RING STR	1

Chapter 9 Illustrated Parts List

9.6 Hydraulic Valve Parts List

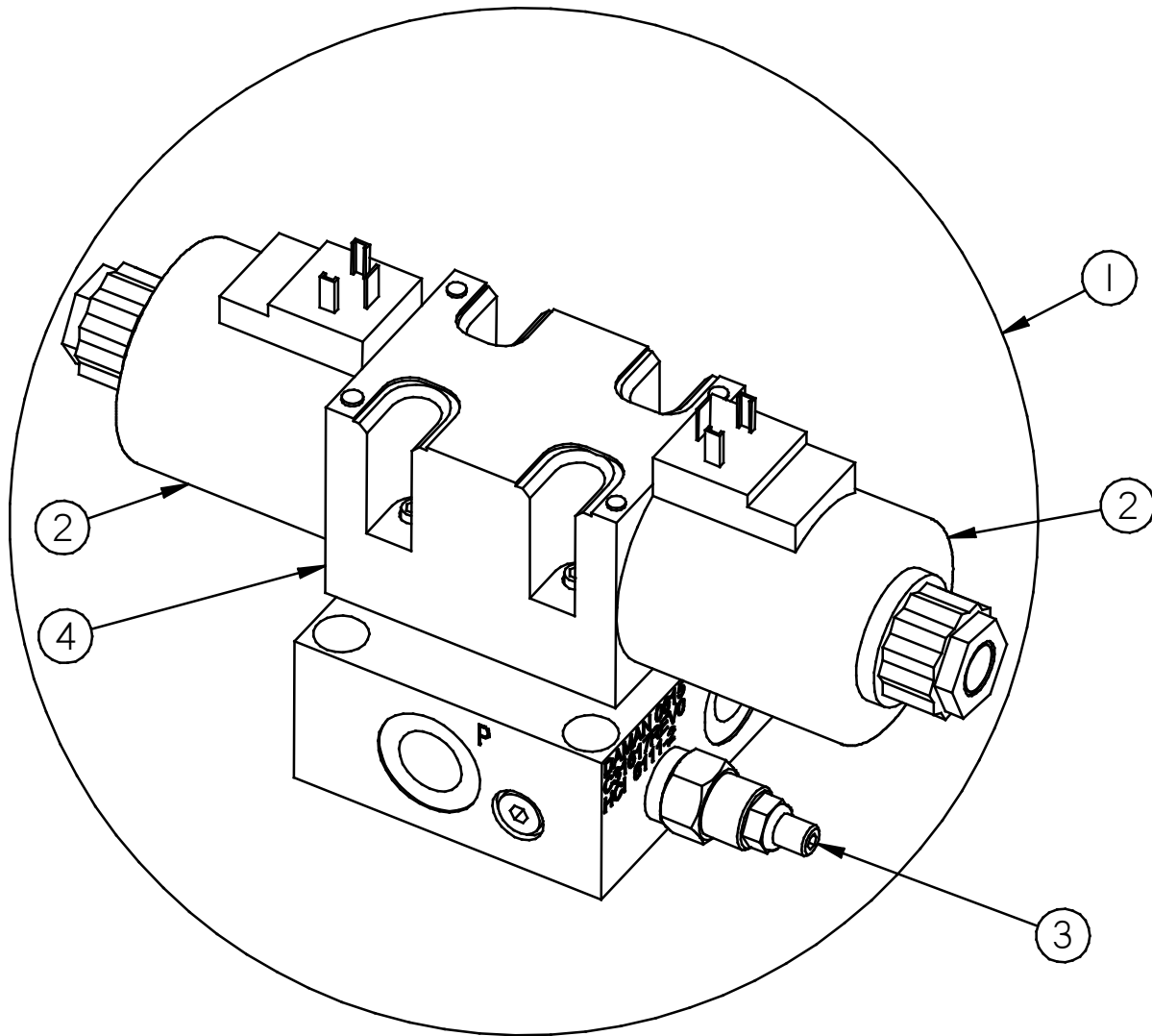

Figure 9-8 Hydraulic Valve

Table 9-8 Hydraulic Valve Parts List

FIG.	ITEM	PART NO.	DESCRIPTION	QTY
Fig. 9.8	1	56340	HYDRAULIC VALVE ASSEMBLY	1
	2	56481	COIL, DIRECTIONAL VALVE	2
	3	44812	PRESSURE RELIEF VALVE	1
	4	56483	DIRECTIONAL VALVE BLOCK	1

Chapter 9 Illustrated Parts List

9.7 Safety Chain Parts List

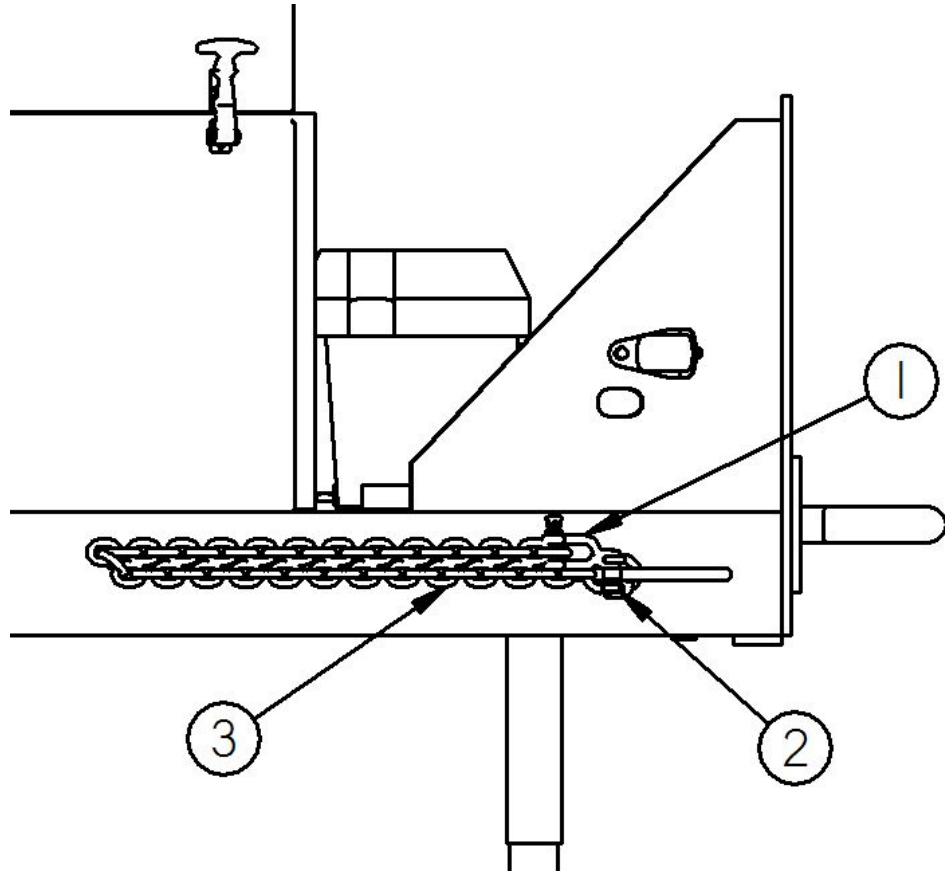

Figure 9-9 Safety Chains

Table 9-9 Safety Chains Parts List

FIG.	ITEM	PART NO.	DESCRIPTION	QTY
Fig. 9.9	1	20144	3/8" CHAIN SHACKLE W/ SCREW PIN	2
	2	20132	SHACKLE CONNECTING LINK	2
	3	20130	48" X 3/8" CHAIN	2

Chapter 9 Illustrated Parts List

9.8 Diesel Burner Fuel Line Schematic

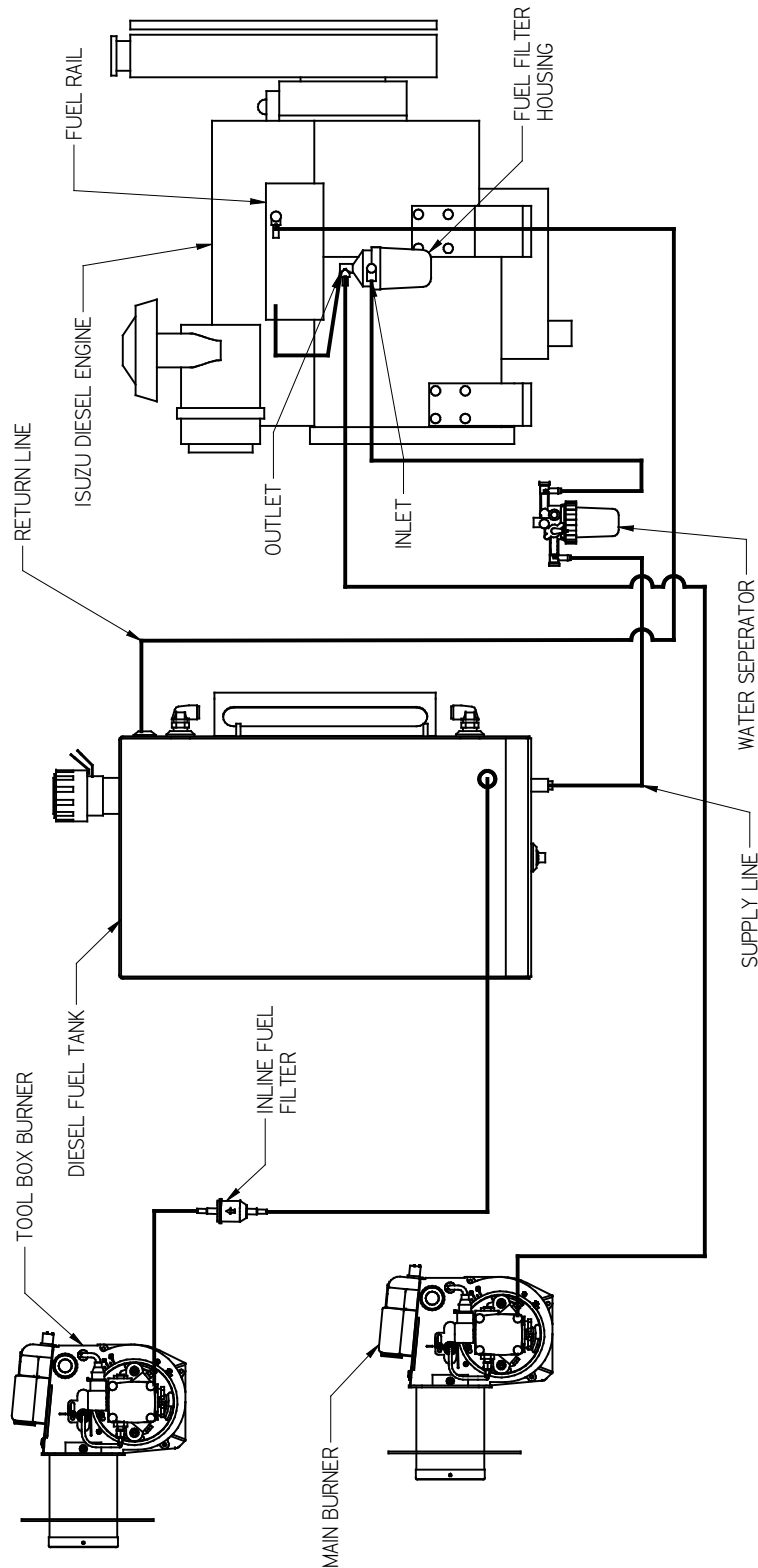

Figure 9-10 Burner Fuel Line Schematic (PN 26599)

Chapter 9 Illustrated Parts List

This page is left blank on purpose

Chapter 9 Illustrated Parts List

9.9 Main Diesel Burner Parts List (P/N 46380)

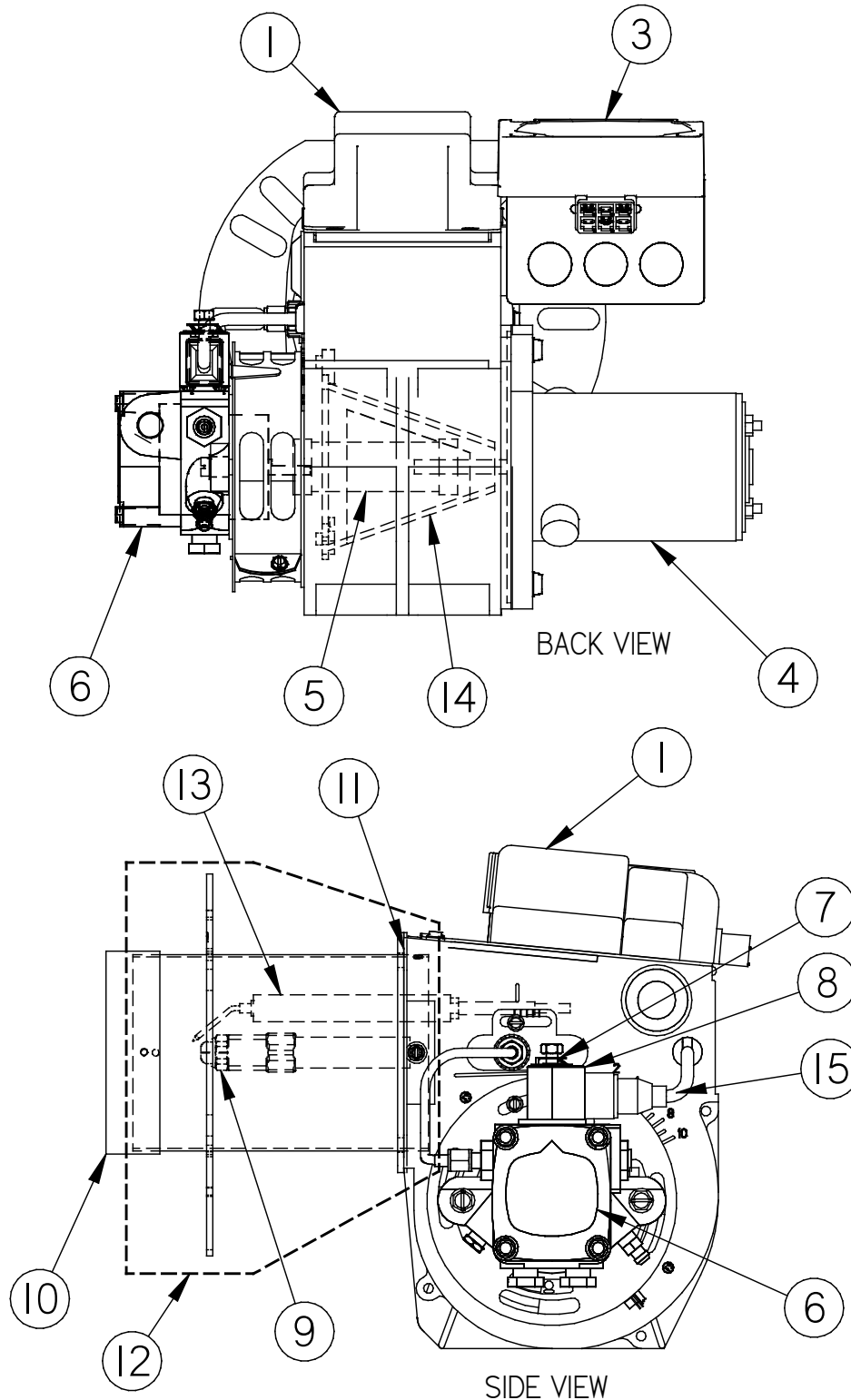

Figure 9-11 Main Diesel Burner (P/N 46380)

Chapter 9 Illustrated Parts List

Table 9-10 Main Diesel Burner Parts List (P/N 46380)

FIG.	ITEM	PART NO.	DESCRIPTION	QTY
Fig. 9.11	1	41949	IGNITION TRANSFORMER	1
	2	41870	CAD EYE (NOT SHOWN)	1
	3	42335	DC CONTROLLER	1
	4	41890	BLOWER MOTOR	1
	5	41970	COUPLING, FUEL PUMP	1
	6	41892	PUMP, FUEL	1
	7	41932	VALVE STEM, FUEL SOLENOID	1
	8	41933	COIL, FUEL SOLENOID	1
	9	44785	BURNER NOZZLE, (2.25) *NOT INCLUDED W/ 46380	1
	10	44786	EXTENDED HEAD, F220, *NOT INCLUDED W/ 46380 or 46381N	1
	11	41964N	GASKET, AIR TUBE TO HOUSING	1
	12	46381N	AIR TUBE W/ HEAD & ELECTRODE MOUNT	1
	13	41993	ELECTRODE ASSY (COMES WITH 2)	1
	14	41966N	AIR GUIDE, BURNER	1

9.10 Tool Box Diesel Burner Parts List (P/N 57485N)

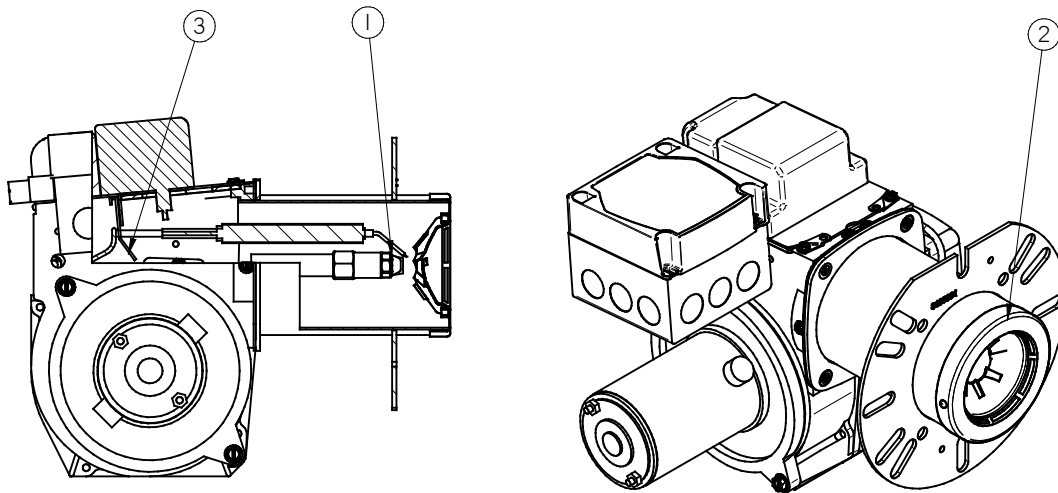

Figure 9-12 Tool Box Diesel Burner (P/N 57485N)

Table 9-11 Tool Box Diesel Burner (P/N 57485N)

FIG.	ITEM	PART NO.	DESCRIPTION	QTY
Fig. 9.12	1	32403	BURNER NOZZLE (0.5)	1
	2	32401	HEAD DIFFUSER, SPECIAL FOR TOOL BOX	1
	3	32400	INTERNAL BAFFLE PLATE, SPECIAL FOR T.B.	1

Chapter 9 Illustrated Parts List

9.11 Control Box Parts List

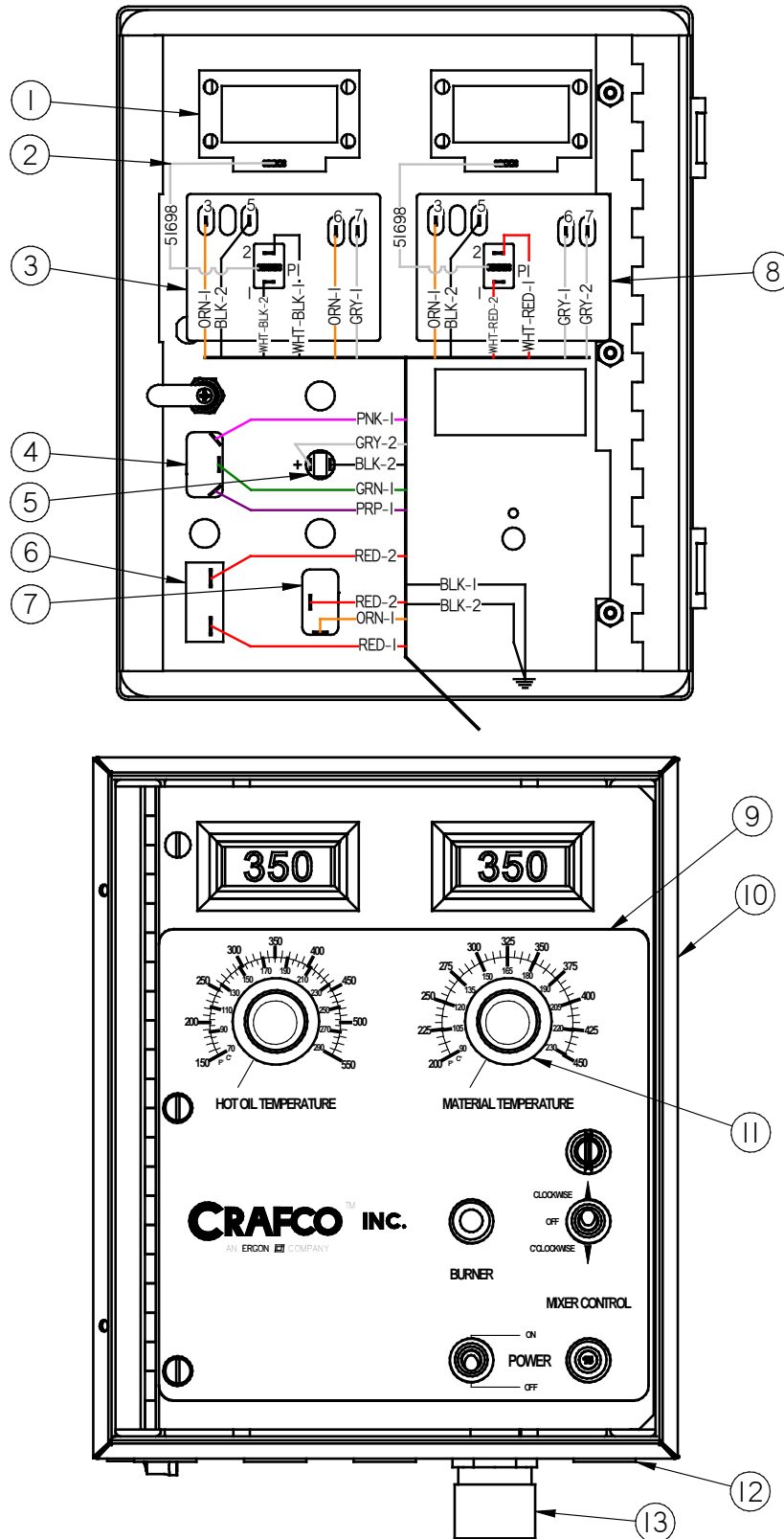

Figure 9-13 Control Box Parts List (P/N 57856)

Chapter 9 Illustrated Parts List

Table 9-12 Control Box Parts List

FIG.	ITEM	PART NO.	DESCRIPTION	QTY
Fig. 9.13	1	50251	READOUT, LCD	2
	2	51698	CABLE, 5" RIBBON	2
	3	57863	TEMP CONTROLLER 200-450 DEGREE	1
	4	56351	SWITCH, 3 POLE	1
	5	51651	LIGHT, PILOT 12VDC	1
	6	51665	CIRCUIT BREAKER	1
	7	50719	SWITCH, TOGGLE SPST	1
	8	43391	TEMP CONTROLLER (P64A0918-903)	1
	9	57864	DECAL, CONTROL BOX PATCHER II	1
	10	44860	ENCLOSURE	1
	11	50593	CONTROL KNOB	2
	12	24270	PLUG, 7/8" HOLE	4
	13	40446	CORD CONNECTOR	1

Chapter 9 Illustrated Parts List

9.12 Electrical Schematic Parts List

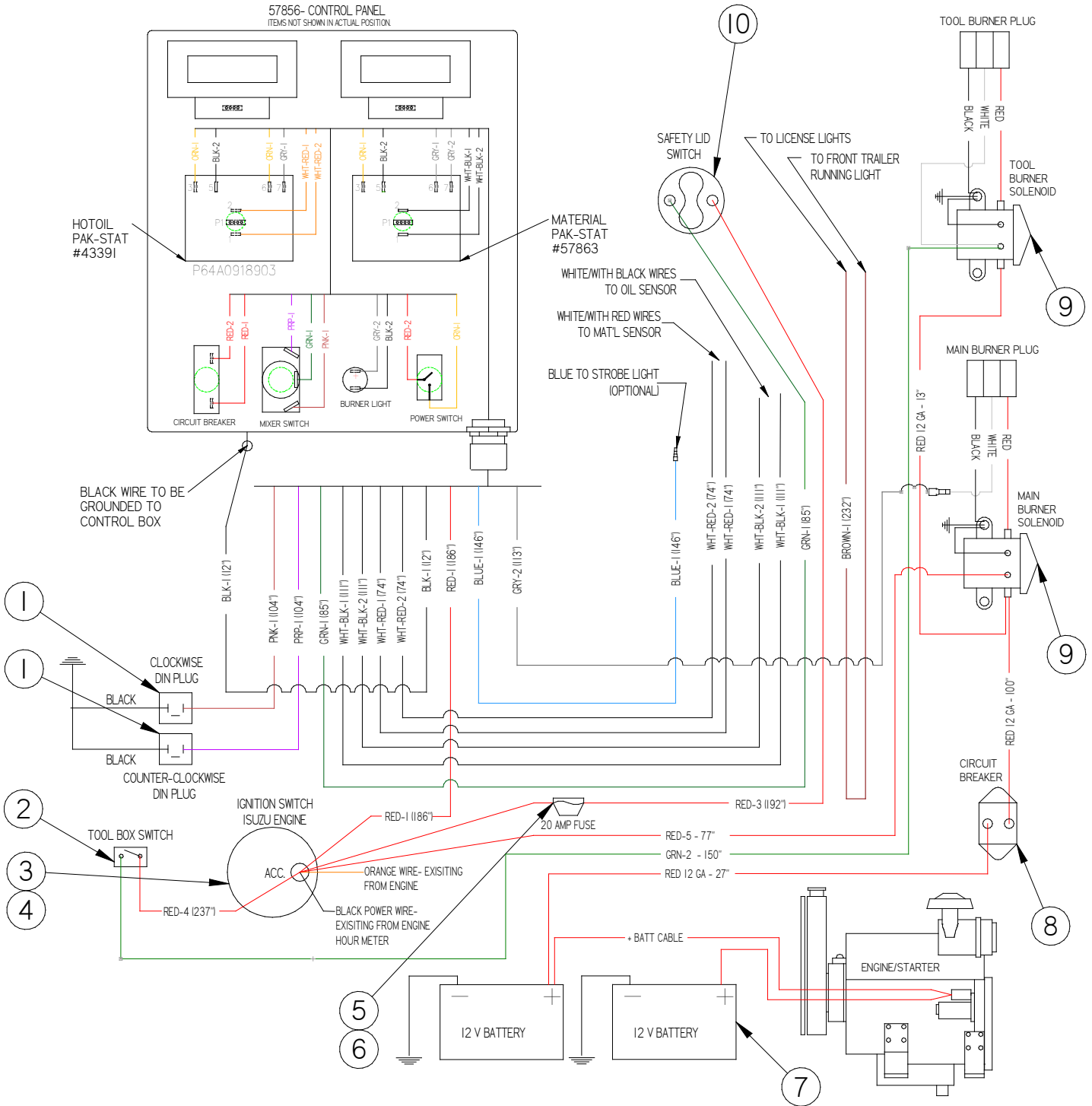

Figure 9-14 Electrical Schematic Parts List (PN 26582)

Chapter 9 Illustrated Parts List

Table 9-13 Electrical Schematic Parts List

FIG.	ITEM	PART NO.	DESCRIPTION	QTY
Fig. 9.14	1	45376	DIN PLUG, W/ CABLE	2
	2	39566	SINGLE POLE SWITCH	1
	3	41994	IGNITION SWITCH W/O TUMBLER	1
	4	41948	IGNITION TUMBLER	1
	5	31514	20 AMP INLINE FUSE HOLDER	1
	6	32510	20 AMP ATP BLADE FUSE	1
	7	24000	SEALED BATTERY 12-VOLT 24-2	2
	8	31512	CIRCUIT BREAKER	1
	9	39602	SOLENOID, BURNER	2
	10	39608	AUTOSTOP LID SWITCH	1

Chapter 9 Illustrated Parts List

9.13 Optional Material Chute Parts List (P/N 56825)

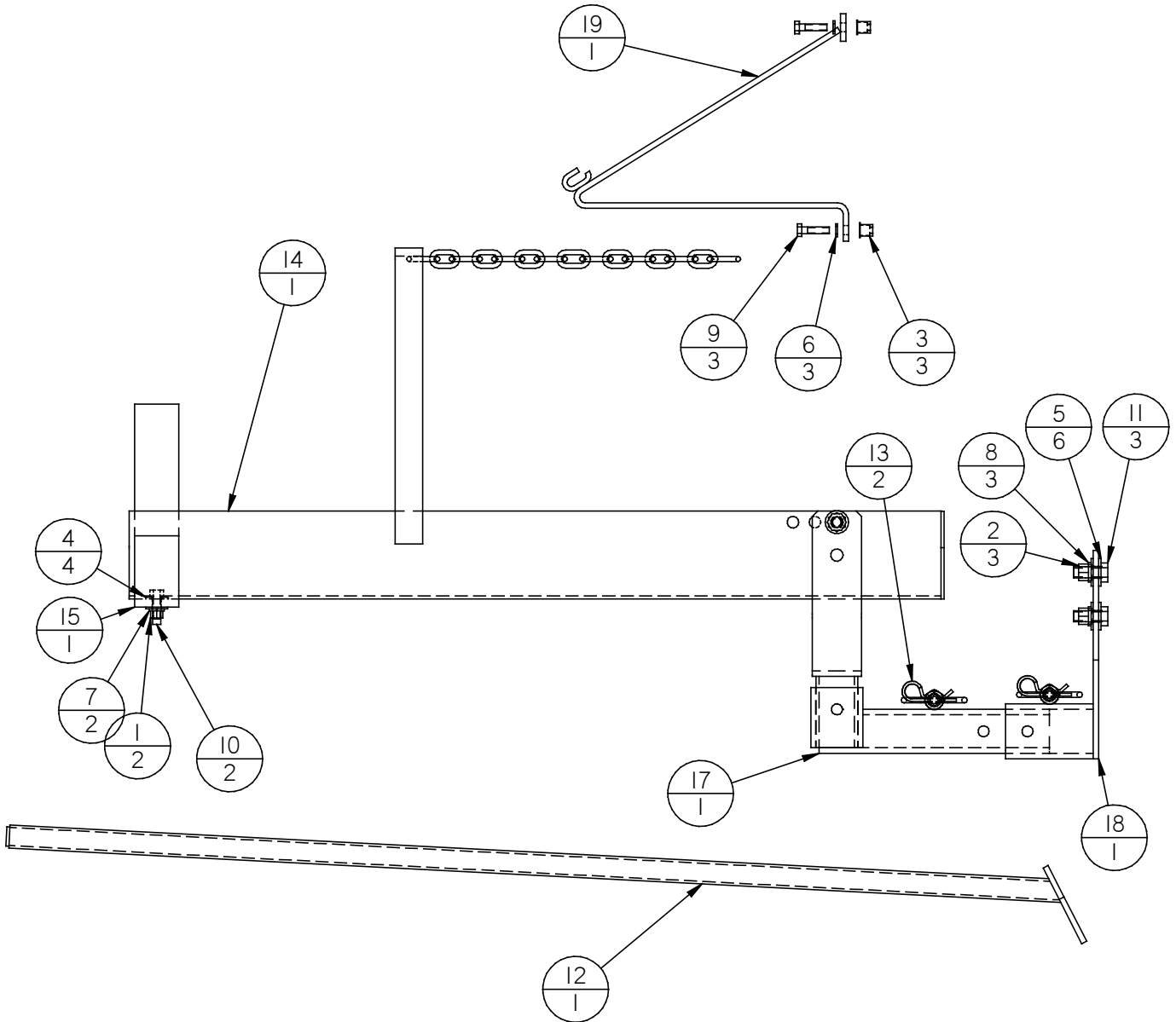

Figure 9-15 Optional Material Chute (P/N 56825)

Chapter 9 Illustrated Parts List

Table 9-14 Optional Material Chute

FIG.	ITEM	PART NO.	DESCRIPTION	QTY
Fig. 9.15	1	28526	NUT, 3/8-16 ESNA HEX	2
	2	28528	½-13 ESNA LOCK NUT	3
	3	28608	5/16 THREADED INSERT	3
	4	28634	WASHER, 3/8 USS	4
	5	28636	½" FLAT WASHER	6
	6	28646	WASHER, 5/16' LOCK	3
	7	28647	WASHER, 3/8" LOCK	2
	8	28649	WASHER ½" LOCK	3
	9	28717	BOLT, 5/16-18 X 1-1/4" HEX HEAD	3
	10	28732	BOLT, 3/8-16 X 1-1/4" HEX HEAD	2
	11	28761	BOLT, ½-13 X 1 ½ HEX HEAD	3
	12	32239	MATERIAL CHUTE SCOOP ASSY	1
	13	44462	HITCH PIN	2
	14	44680	MATERIAL CHUTE ASSY	1
	15	44744	CHUTE SUPPORT ASSY	1
	17	56812	EXTENDED MOUNTING BASE PL ASSY	1
	18	56822	BUMPER MOUNTING- MATRL CHUTE ASSY	1
	19	56864	CHUTE CHAIN BRACKET ASSY	1

Chapter 9 Illustrated Parts List

Table 9-15 Hydraulic Schematic for Optional Heated Chute Parts List

FIG	ITEM	PART NO.	DESCRIPTION	QTY
Fig.9.16	1. HYDRAULIC RESERVOIR TO HYDRAULIC PUMP (SUCTION)			
		29819	3/4" TUBE X 3/4" STD THRD O-RING STR	1
	1	12G4H 12G-12FJX90S 12G-16FJX 29 24.25	29" SUCTION HOSE	1
		29824	1" TUBE X 1" STD THRD. O-RING 90° ELBW	1
	2. HYDRAULIC PUMP TO FLOW CONTROL VALVE "PR" PORT			
		29821	5/8" TUBE X 3/4" STD. THRD. O-RING STR	1
	2A	10M3K 10G-10FJX 10G-10FJX 28 24.5	HYD HOSE X 28" LONG	1
		29805	5/8" TUBE BULKHEAD FITTING	1
		29807	7/8-14 BULKHEAD LOCKNUT	1
	2B	10M3K 10G-10FJX90S 10G-10FJX 20.75 17	HYD HOSE X 20 3/4" LONG	1
		29805	5/8" TUBE BULKHEAD FITTING	1
		29807	7/8-14 BULKHEAD LOCKNUT	1
	2C	10M3K 10G-10FJX90S 10G-10FJX 25.25 21	HYD HOSE X 25 1/4" LONG	1
		29805	5/8" TUBE BULKHEAD FITTING	1
		29807	7/8-14 BULKHEAD LOCKNUT	1
	2D	10M3K 10G-10FJX 10G-10FJX 33.5 30	HYD HOSE X 33 1/2" LONG	1
		29813	5/8" TUBE X 3/4" NPT 90° ELBOW	1
	3. FLOW CONTROL VALVE "REG" PORT TO HYD VALVE INLET "IN"			
		29822	1/2" TUBE X 3/4" NPT 90° ELBOW	1
	3	8M3K 8G-8FJX 8G-8FJX 65.5 62.25	HYD HOSE X 65 1/2" LONG	1
		29868	1/2" TUBE X 5/8" STD. THRD. O-RING 90°	1
	4. HYD VALVE PORT "A" TO BOTTOM MOTOR PORT			
		29828	3/8" TUBE X 5/8" STD. THRD. O-RING 90°	1
	4	6M3K 6G-6FJX90S 6G-6FJX 20 17.75	HYD HOSE X 20" LONG	1
		22029	3/8" TUBE X 5/8" STD. THRD. O-RING STR	1
	5. TOP MOTOR PORT TO HYD VALVE PORT "B"			
		22029	3/8" TUBE X 5/8" STD. THRD. O-RING STR	1
	5	6M3K 6G-6FJX90L 6G-6FJX90S 27.5 23.25	HYD HOSE X 27 1/2" LONG	1
	22029	3/8" TUBE X 5/8" STD. THRD. O-RING STR	1	

Chapter 9 Illustrated Parts List

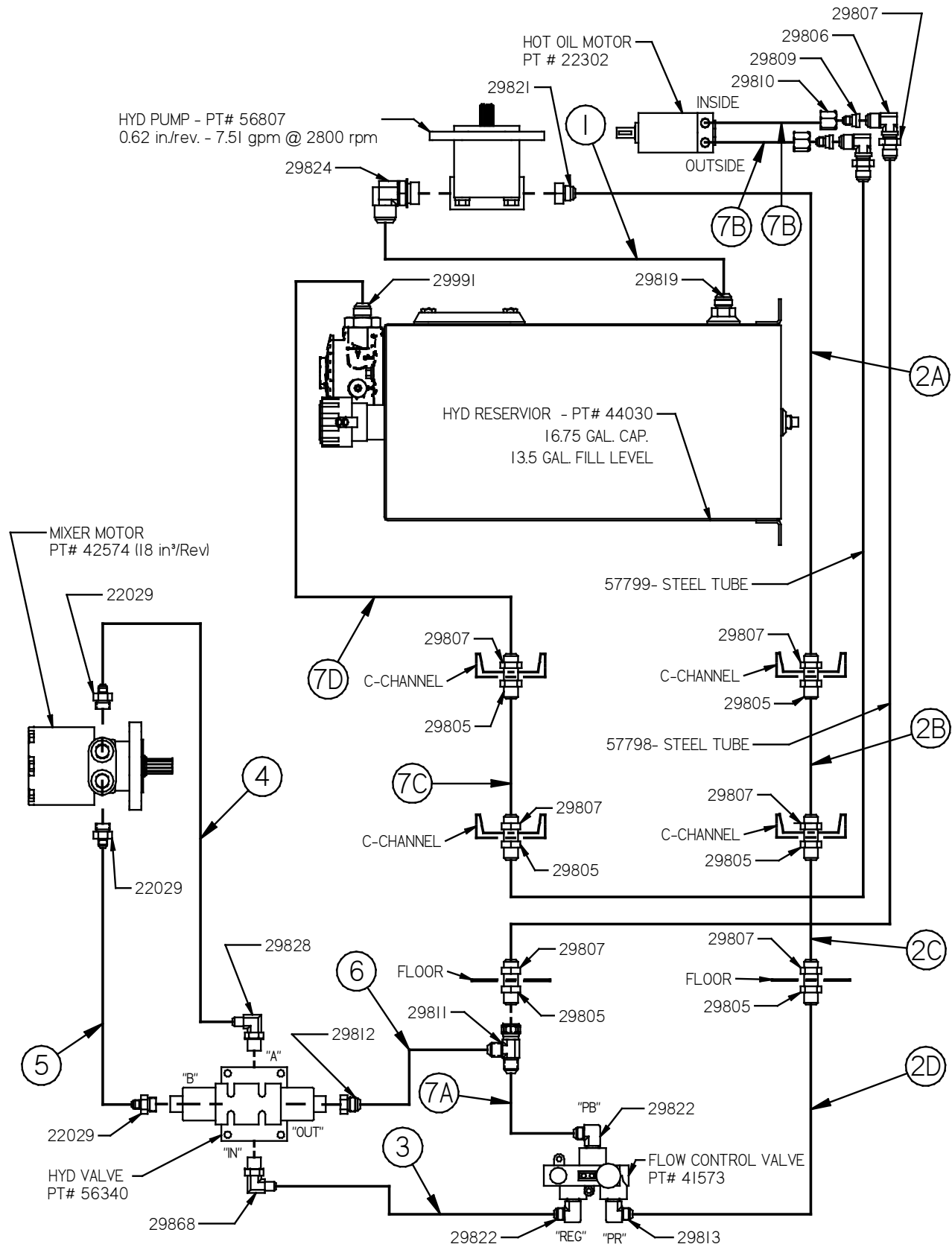

Figure 9-17 Hydraulic Schematic for Optional Heated Chute (PN 26569) (continued)

Chapter 9 Illustrated Parts List

Table 9-16 Hydraulic Schematic for Optional Heated Chute Parts List (continued)

FIG	ITEM	PART NO.	DESCRIPTION	QTY
Fig.9.17	6. HYDRAULIC VALVE "OUT" PORT TO "T" RETURN LINE			
		29812	5/8" TUBE X 5/8" STD. THRD. O-RING STR	1
	6	8M3K 8G-10FJX 8G-10FJX 24 21.5	HYD HOSE X 24" LONG	1
	7. FLOW CONTROL VALVE "PB" PORT TO HYD RESERVOIR RETURN PORT			
		29822	1/2" TUBE X 3/4" NPT 90° ELBOW	1
	7A	8M3K 8G-8FJX 8G-10FJX 33 29.75	HYD HOSE X 33" LONG	1
		29811	5/8" TUBE X 5/8" TUBE SWIVEL NUT RUN T	1
		29805	5/8" TUBE BULKHEAD FITTING	1
		29807	7/8-14 BULKHEAD LOCKNUT	1
		57798	STEEL HYD. TUBE 90° END	1
		29807	7/8-14 BULKHEAD LOCKNUT	2
		29806	5/8" TUBE BULKHEAD ELBOW	2
		29809	5/8" TO 3/8" TUBE REDUCER	2
		29810	5/8" TUBE NUT	2
	7B	6M3K 6G-6FJX 6G-6FJX90S 15.25 11.75	HYD HOSE X 15 1/4" LONG	2
		57799	STEEL HYD. TUBE STR END	1
		29807	7/8-14 BULKHEAD LOCKNUT	1
		29805	5/8" TUBE BULKHEAD FITTING	1
	7C	10M3K 10G-10FJX90L 10G-10FJX 20.25 16.5	HYD HOSE X 20 1/4" LONG	1
		29807	7/8-14 BULKHEAD LOCKNUT	1
		29805	5/8" TUBE BULKHEAD FITTING	1
	7D	10M3K 10G-12FJX90S 10G-10FJX 34.5 30	HYD HOSE X 34 1/2" LONG	1
		29991	3/4" TUBE X 1 1/4" STD. THRD. O-RING STR	1

Chapter 9 Illustrated Parts List

9.15 Optional Heated Chute Parts List (P/N 57783)

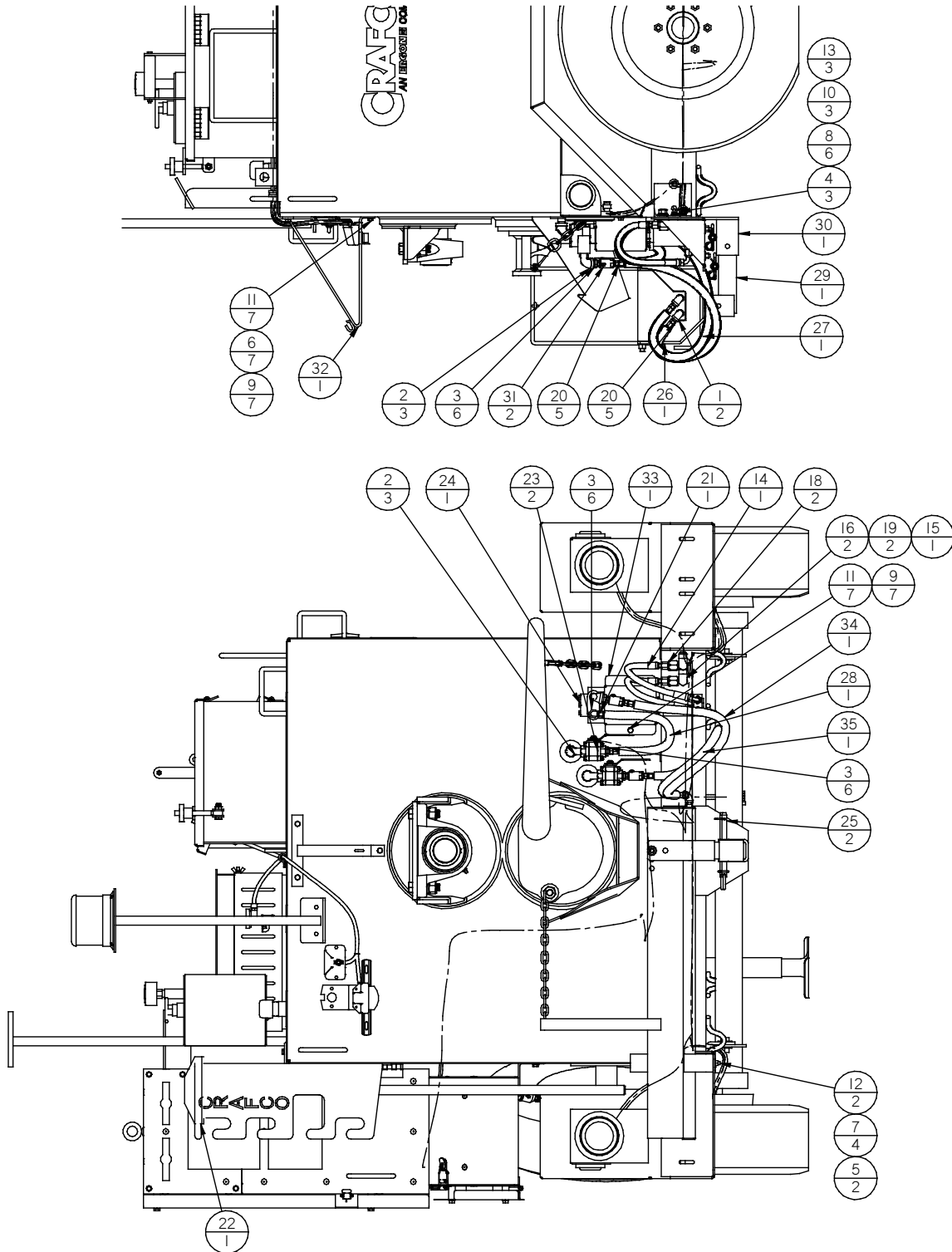

Figure 9-18 Optional Heated Chute (P/N 57783)

Chapter 9 Illustrated Parts List

Table 9-17 Optional Heated Chute Parts List

FIG.	ITEM	PART NO.	DESCRIPTION	QTY
Fig. 9.18	1	28206	¼" PIPE ELBOW	2
	2	28238	½" STREET ELBOW	3
	3	28344	½" X ¼" BUSHING	6
	4	28504	NUT, 1/2-13 HEX	3
	5	28526	NUT, 3/8-16 ESNA HEX	2
	6	28608	5/16-18 THREADED INSERT	7
	7	28634	WASHER, 3/8 USS	4
	8	28636	½" FLAT WASHER	6
	9	28646	WASHER, 5/16' LOCK	7
	10	28649	WASHER ½" LOCK	3
	11	28717	BOLT, 5/16-18 X 1-1/4" HEX HEAD	7
	12	28732	BOLT, 3/8-16 X 1-1/4" HEX HEAD	2
	13	28761	BOLT, ½-13 X 1 ½ HEX HEAD	3
	14	29630	6M3K 6G-6FJX 6G-6FJX90S 15.25 11.75	1
	15	29630	6M3K 6G-6FJX 6G-6FJX90S 15.25 11.75	1
	16	29806	BULKHEAD UNION ELBOW	2
	17	29807	BULKHEAD LOCK NUT 7/8-14	4
	18	29809	REDUCER, 5/8" X 3/8" TUBE	2
	19	29810	NUT, 5/8" TUBE	2
	20	29836	MALE CONNECTOR, 4MP X 4MJ	5
	21	29870	1/4 MPT X 7/16 JIC ELBOW	1
	22	32239	MATERIAL CHUTE SCOOP ASSY	1
	23	41499	½" HOT OIL BALL VALVE	2
	24	41696	PUMP AND MOTOR ASSY, HOT OIL	1
	25	44462	HITCH PIN	2
	26	44740	CHUTE ASSY, HEATED	1
	27	44744	CHUTE SUPPORT ASSY	1
	28	44758	1/4" X 18: TEFLON HOSE	1
	29	56812	EXTENDED MOUNTING BASE PL ASSY	1
	30	56822	BUMPER MOUNTING- MATRL CHUTE ASSY	1
	31	56832	600 DEG SWIVEL FITTING	2

Chapter 9 Illustrated Parts List

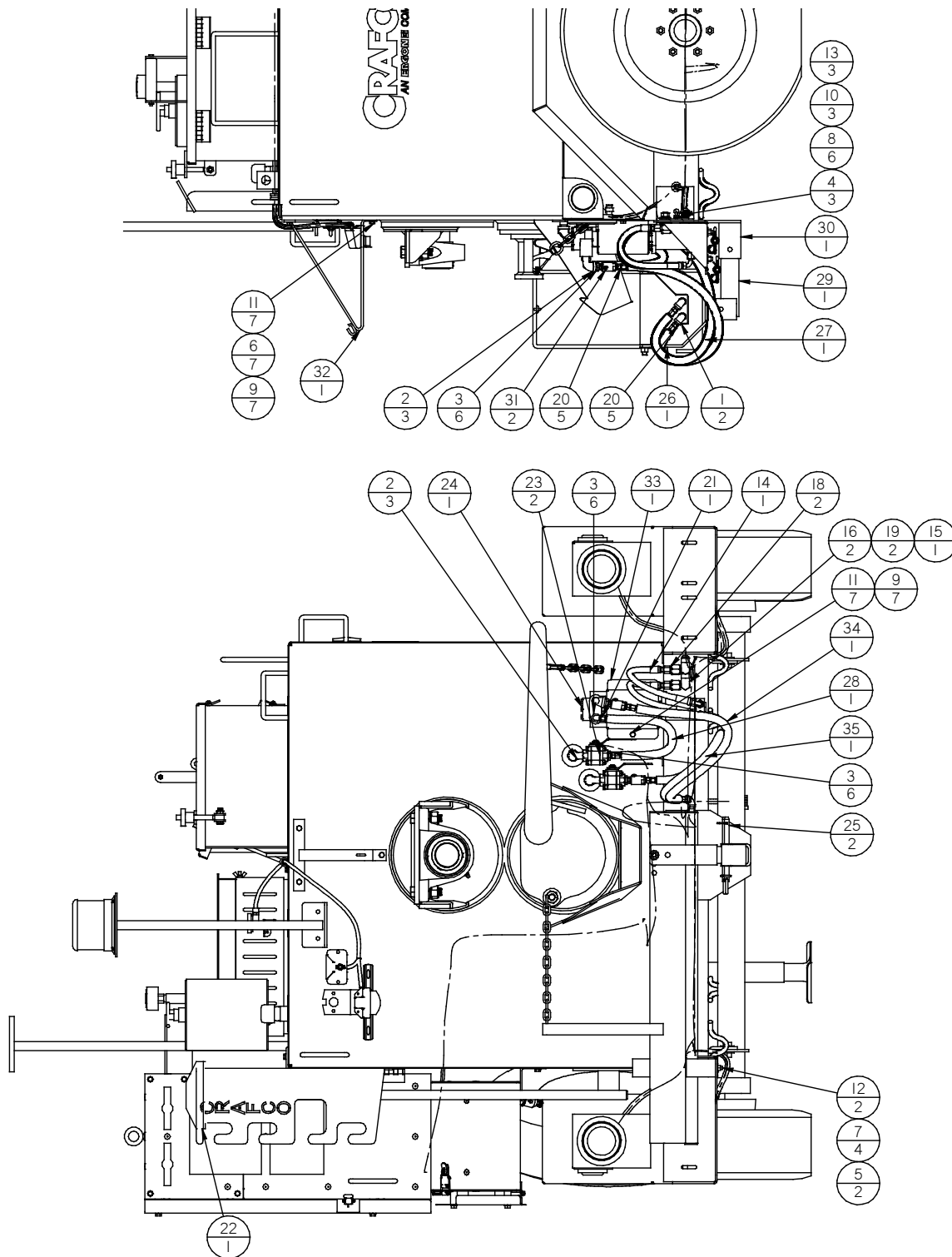

Figure 9-19 Optional Heated Chute Parts List (continued)

Chapter 9 Illustrated Parts List

Table 9-18 Optional Heated Chute Parts List (continued)

FIG.	ITEM	PART NO.	DESCRIPTION	QTY
Fig. 9.19	32	56864	CHUTE CHAIN BRACKET ASSY	1
	33	57782	GUARD, HOT OIL HEATED CHUTE	1
	34	57797	1/4" x 31" TEFLON HOSE	1
	35	57797	1/4" x 31" TEFLON HOSE	1
	36	57798	STEEL HYD. TUBE ASSY, 90° END	1
	37	57799	STEEL HYD. TUBE ASSY, STR END	1

Chapter 9 Illustrated Parts List

9.16 Heated Chute Pump and Motor Assembly (P/N 41696)

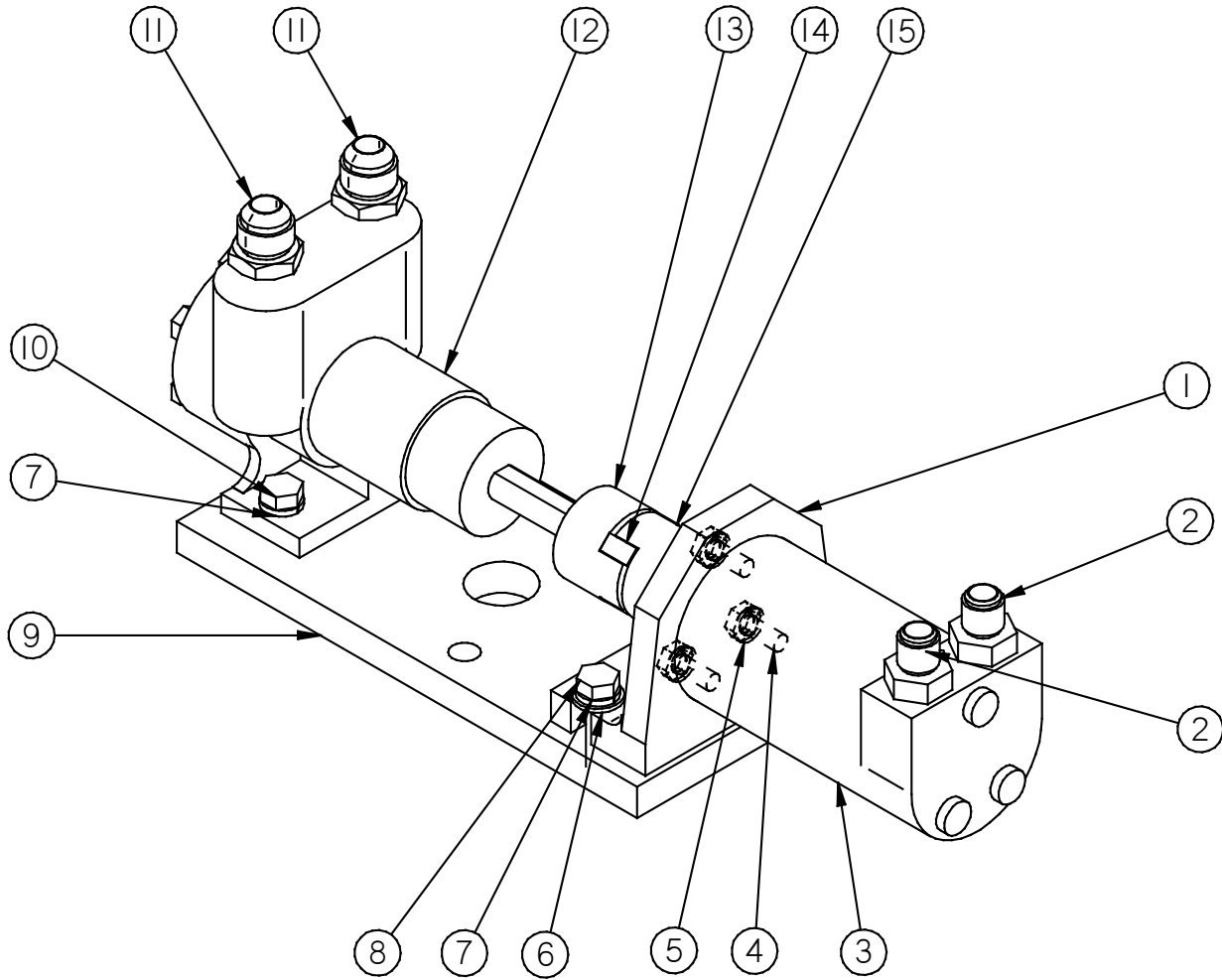

Figure 9-20 Heated Chute Pump and Motor Assembly (P/N 41696)

Chapter 9 Illustrated Parts List

Table 9-19 Heated Chute Pump and Motor Assembly Parts List

FIG.	ITEM	PART NO.	DESCRIPTION	QTY
Fig. 9.20	1	22303	HYD. MOTOR MNTG BRACKET	1
	2	40311	STRAIGHT THREAD ADAPTER	2
	3	22302	HYDRAULIC MOTOR	1
	4	28850	1/4-28 X 5/8" HEX SCREW	3
	5	28645	1/4" SPLIT WASHER	3
	6	28671	5/16" SAE FLAT WASHER	2
	7	28646	5/16" LOCK WASHER	4
	8	28717	5/16-18 X 1 1/4" BOLT	2
	9	41689	H.O. MOUNTING PLATE	1
	10	28715	5/16-18 X 3/4" BOLT	2
	11	29844	ADAPTER, JIC MP 8MJ-8MP	2
	12	41280	HOT OIL CIRCULATING PUMP	1
	13	41180	COUPLING HALF, 1/2" BORE	1
	14	41182	SPIDER FOR COUPLING	1
	15	41695	COUPLING HALF, 5/8" BORE	1
	NS	45622	OIL PUMP REBUILD KIT, INCLUDES BELOW	1
			6 SCREWS, 1 IDLER PIN, 1 HEAD, 1 IDLER, 3 PACKING GLANDS	
	NS	45621	OIL PUMP SEAL KIT, INCLUDES BELOW	1
			1 NUT, 1 OTR GLND, 3 PACK GLNDS, 1 INR GLND, 1 SPRING, 2 HEAD GASKETS	
	NS	45620	3 PACKING GLAND RINGS, OIL PUMP	1

Chapter 9 Illustrated Parts List

9.17 Patcher II Options

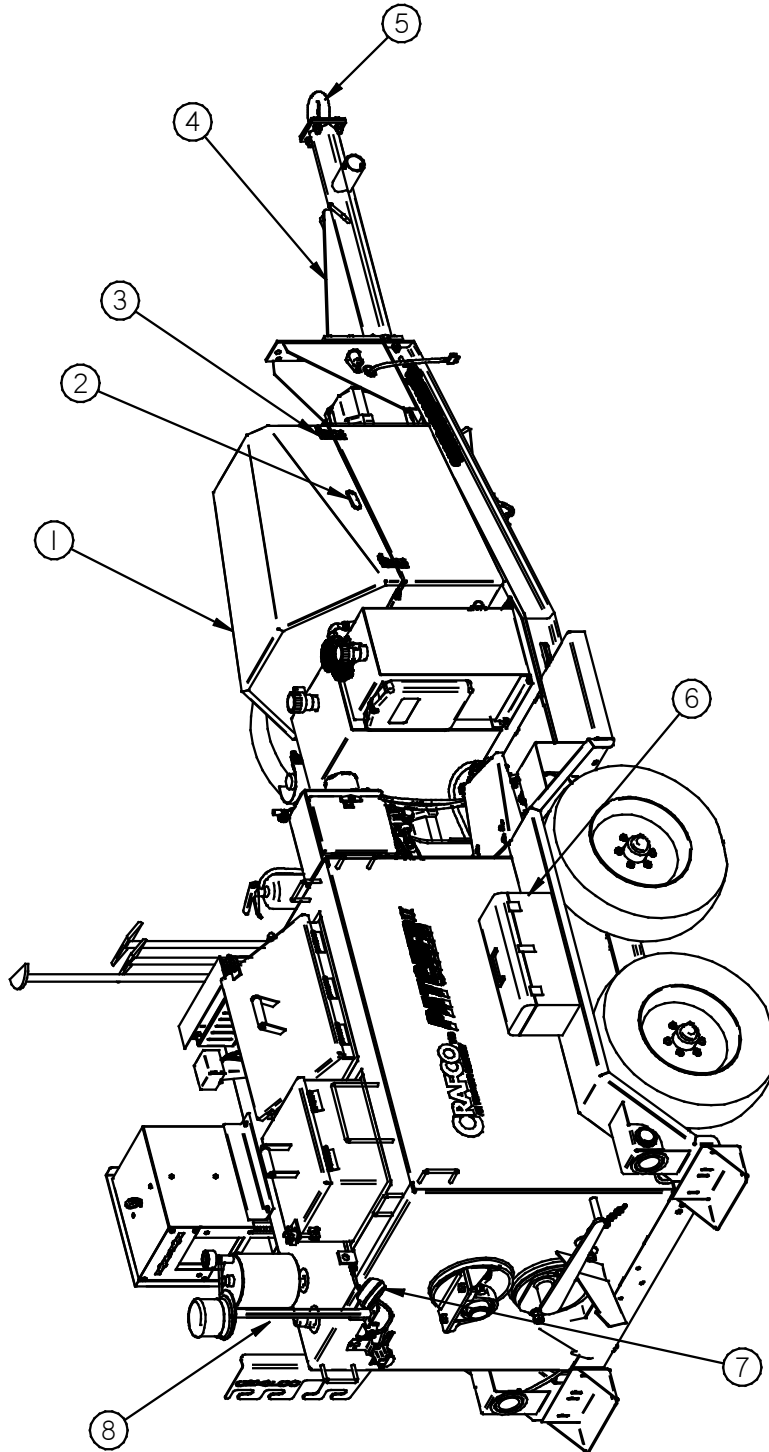

Figure 9-21 Patcher II Options

Chapter 9 Illustrated Parts List

Table 9-20 Options Parts List

FIG.	ITEM	PART NO.	DESCRIPTION	QTY
Fig. 9.21	1	45535	ENGINE COVER	1
	NA	45388	OVERFLOW BOTTLE BRACKET (NOT SHOWN) – USE WITH ENGINE COVER	1
	NA	46748	GAS SPRING FOR ENG COVER (NOT SHOWN)	1
	NA	46374	INSULATION KIT, ENG COVER (NOT SHOWN)	1
	2	43746	NEOPRENE HANDLE ENGINE COVER	1
	3	45597	RUBBER T HANDLE DRAW LATCH ENG CVR	2
	4	20150	39" HITCH EXTENSION	1
	4	20140	28" HITCH EXTENSION	1
	5	20014	3" PINTLE HITCH	1
	5	20016	2½" PINTLE HITCH	1
	6	26098	TOOL BOX	1
	7	56854	REAR WORK LIGHT KIT	1
	8	24095K	MAST MOUNTED STROBE LIGHT, CLASS II	1
	8	24095KCL1	MAST MOUNTED STROBE LIGHT, CLASS I/CA TITLE 13	1

Chapter 9 Illustrated Parts List

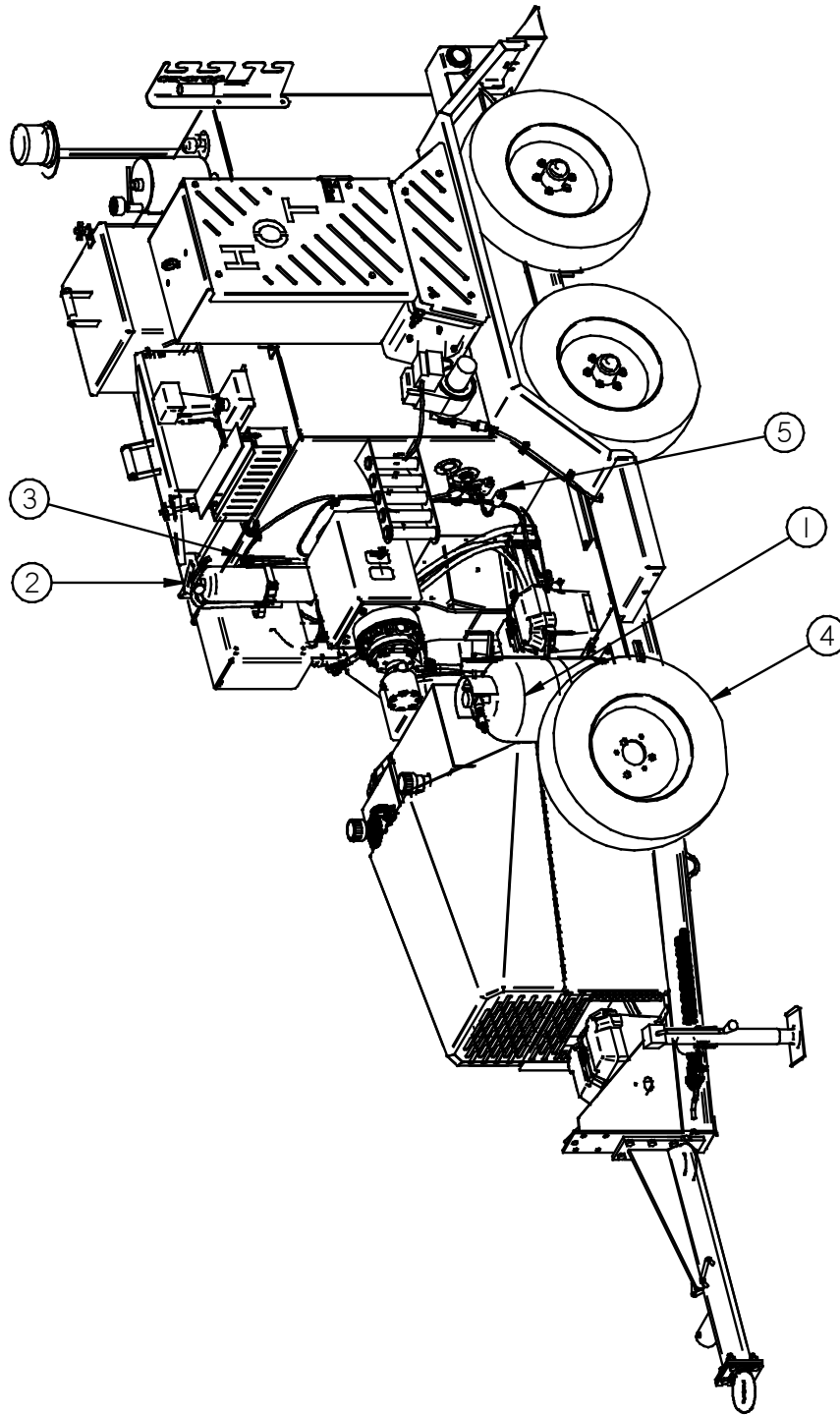

Figure 9-22 Patcher II Options

Chapter 9 Illustrated Parts List

Table 9-21 Options Parts List (continued)

FIG.	ITEM	PART NUMBER	DESCRIPTION	QTY
Fig. 9.22	1	57781	PROPANE TORCH AND BOTTLE	1
	2	26058	FIRE EXTINGUISHER	1
	3	26059	FIRE EXTINGUISHER MOUNT	1
	4	43549	SPARE TIRE MOUNT KIT WITH TIRE & WHEEL	1
	5	24190K	HEATER, FIREROD, 110V	2
	5	24194K	HEATER, FIREROD, 220V	2
	NA	45438	EXTRA HYDRAULIC FILTER (NOT SHOWN)	1

Chapter 10 Tools and Accessories

10.0 Tools and Accessories

Patching Tools



CrafcO Ironing Wand w/ 4 ft. 6 in. handle
PN# 32243
Used as a leveling and a warming tool for the proper application of TechCrete.

CrafcO Chute Scraper w/ 2 ft. handle
PN# 32246
Used for cleaning the chute on the Patcher I and Patcher II.

CrafcO Tank Scraper w/ 6 ft. handle
PN# 32258
Used for cleaning the Patcher I and Patcher II tanks.

CrafcO Shoebox w/ 6 ft. Handle
PN# 32350 - 8"x 8"x 3" | PN# 32255 - 8"x 8"x 6"
PN# 32351 - 8"x 10"x 3" | PN# 32250 - 8"x 10"x 6"
PN# 32352 - 8"x 12"x 3" | PN# 32252 - 8"x 12"x 6"
PN# 32353 - 8"x 14"x 3" | PN# 32253 - 8"x 14"x 6"
Used for assisting placement of PolyPatch. Use the size suitable for your application. Fill using the Material Handler or TechCrete Bucket.

Lances / Torches



CrafcO Hand Torch
PN# 25012 - 20 ft. Hose
PN# 25016 - 12 ft. Hose
PN# 25021 - 50 ft. Hose
Used on the E-Z Pour 50, Patcher I and Patcher II.



CrafcO Cold Air Lance
PN# 42648
Use this tool in conjunction with an air compressor to blow cracks and joints clean.



CrafcO High Velocity Heat Lance
PN# 45650
Requires air compressor and propane supply. Features Auto ignition and includes moisture trap, regulator and 40 ft. hose.



CrafcO Low Velocity Heat Lance
PN# 32259
Use to dry out, heat and clean cracks. Requires air compressor and propane supply. Includes regulator and 50 ft. hose.

Chapter 10 Tools and Accessories



**Crafcoco Heavy Duty Squeegee
w/Aluminum Handle**

PN# 27199

Crafcoco Replacement Blade PN# 27195
4 in. x 18 in. x 3/8 in.

**Crafcoco Heavy Duty Compact
Squeegee w/Wood or Aluminum
Handle**

PN# 27245

PN#2745W (Wood Handle)

Crafcoco Replacement Blade PN# 27241
2 ½ in. x 17 in. x 3/8 in.



Crafcoco TechCrete Bucket

PN # 32263

For transporting TechCrete or
PolyPatch material from the
Patcher I or Patcher II to the
repair area.



Crafcoco Hot Mastic Applicator

PN# 57650

For handling and distributing of
patching materials from the
Patcher I or Patcher II to the
repair area. Propane heated
with material side discharge
gate.



©2019 Crafco, Inc.