



**MODEL 200  
PAVEMENT CUTTER**

**PART MANUAL - 26340  
Rev. "C"**

Revised: 2/2007

## MODEL 200 PAVEMENT CUTTER



# TABLE OF CONTENTS

Model 200 Pavement Cutter.....	5
Safety Precautions.....	6
Limited Warranty.....	7
Warranty Claim Instructions.....	8
Specifications.....	9
Introduction.....	10
Operating Instructions	
Machine Start Up.....	11-12
Engine Operating Instructions.....	12-13
Storing the Machine.....	14
Instructions for Ordering Parts.....	14
Stabilizer Mechanism.....	15
Maintenance	
Maintenance.....	16-17
Periodic Maintenance.....	18
Maintenance Schedule.....	19
Service and Maintenance Instructions.....	20-21
Changing Cutters.....	22
Alternate Cutter Positioning.....	23
Installing New Cutter Head and Main Shaft.....	24
Changing Cutter Heads.....	25
Changing V-Belts.....	26
Electric Clutch.....	26
Trouble-Shooting	
Trouble-Shooting Guide.....	26
Parts	
Cutter Head Assembly Complete - Diagram and Parts.....	27-28
Pavement Cutter Selection.....	29
Cutter Installation Warning.....	30
Cutter Positioning.....	31-32
Model 200 Pavement Cutter Diagrams and Parts.....	33-37

# MODEL 200 PAVEMENT CUTTER

This manual is furnished with each new **CRAFECO PAVEMENT CUTTER**. This manual will help your machine operators learn to run the machine properly and understand its mechanical functions for trouble-free operation.

Your **CRAFECO MODEL 200** is designed to give excellent service and save maintenance expense. However, as with all specifically engineered equipment, you can get best results at minimum costs if:

- (1) You operate your machine as instructed in this manual, and
- (2) Maintain your machine regularly as stated in this manual.



## **WARNING:**

The engine exhaust from this product contains chemicals known to the State of California to cause cancer, birth defects or other reproductive harm. Operate in well ventilated area only. Engine exhaust is deadly.

Manufactured under U.S. Patent Numbers 4,175,788, and 4,204,714, and Canadian Patent Number 1,098,355.

Other Patents Pending.



## SAFETY PRECAUTIONS

1. Eye and ear protective devices are required when operating the CRAFCO Model 200 Pavement Cutter. A respirator should also be worn if the surface being worked with is dry.



2. Care should be taken when operating machine on grades. It is usually best to operate the machine going up hill.
3. To stop or slow machine, push down on handle.
4. When cleaning joints near moving traffic, always move in a direction away from traffic to protect the operator.
5. Tires should be inflated to 45 psi to allow machine to roll easily.
6. Never transport the router with the engine running.
7. Never exceed maximum recommended engine RPM.
8. Never leave router unattended while engine is running.
9. Never stand on any part of the machine.
10. The only operating position is behind the pavement cutter with both hands on the handle.
11. Wear long pants, and heavy leather boots or shoes.

# MODEL 200 PAVEMENT CUTTER LIMITED WARRANTY

Crafco, Inc., through its authorized distributor, will replace for the original purchaser free of charge any parts found upon examination by the factory at Mesa, Arizona, to be defective in material or workmanship. This warranty is for a period within 60 days of purchase date, but excludes engine or components, tires, and battery as these items are subject to warranties issued by their manufacturers.

The responsibility of Crafco under this warranty is limited to replacement or repair of defective parts at Crafco's Chandler, Arizona factory, or at a point designated by it, of such parts as shall appear to Crafco, upon inspection at such point, to have been defective in material or workmanship, with expense for transportation to be born by the original purchaser. The labor covered by this warranty includes only that labor which is required to repair the defective part itself, and not that labor required to gain access to the part.

Crafco, Inc. shall only be liable when the equipment is used in compliance with those directions specified in the manufacturer's instructions.

The warranty provided herein extends only to the repair and/or replacement of those components on the equipment covered above and does not extend to incidental or consequential damages incurred as a consequence of any defects covered by this warranty.

This warranty shall not apply to any machine or parts altered and modified without Crafco's consent, nor shall it apply to normal wear and tear or when misuse, negligence or accident are evident, or when machines have been operated at speeds or loads beyond factory-rated capacities or specifications.

All warranties expressed or implied are void if other than genuine Crafco cutters and pins are used.

Crafco, Inc. specifically disavows any other representation, warranty, or liability related to the condition or use of the product.



**WARNING:**

Use of replacement parts other than genuine Crafco parts may impair the safety or reliability of your equipment and nullifies any warranty.

# WARRANTY CLAIM INSTRUCTIONS

Please follow the instructions stated below when calling in a Warranty Claim. Failure to follow these procedures may be cause to void the warranty.

1. Call your local CrafcO Distributor. If you do not know who your local distributor is, call a CrafcO Customer Service Representative, (Toll Free 1-800-528-8242) for name, location, and telephone number.
2. On contacting the distributor, be prepared to identify the serial number, model number, engine model, engine manufacturer, and the date of purchase if available.

Serial Number: \_\_\_\_\_

Model Number: \_\_\_\_\_

Engine Model (H.P.): \_\_\_\_\_

Engine Manufacturer: \_\_\_\_\_

Date of Purchase: \_\_\_\_\_

3. Should the cause of the malfunction be a defective part, the Distributor will advise you of the procedure to follow for a replacement.
4. The warranty is valid only for parts, which have been supplied or recommended by CrafcO, Inc.

If you have any additional questions regarding warranty repairs and parts, please do not hesitate to call toll free 1-800-528-8242.

CRAFCO, INCORPORATED  
235 SOUTH HIBBERT DRIVE  
MESA, AZ. 85210  
480-655-8333  
Toll Free 1-800-528-8242



## SPECIFICATIONS

Engine.....	2 Cylinder- CH25 (25 HP)
Weight.....	425 Lbs.
Fuel.....	Unleaded Gasoline
Fuel Tank Capacity.....	6 Gallons
Maximum Depth of Cut.....	1 - 5/8"
Depth.....	Depth gauge for precise depth control.
Safety Features.....	Braking system, safety guards, electric clutch
Depth Control.....	Electric actuator for fingertip depth control.
Cutter Design.....	6 radially located sprocket shaped cutters on 11 3/4" diameter cutter head
Cutter Style:.....	Hardened steel with carbide cutter tips
Crack Cleaning.....	Up to 1500 L.F. per hour

# MODEL 200 PAVEMENT CUTTER OPERATING INSTRUCTIONS

## INTRODUCTION

The **CRAFCO Model 200 Pavement Cutter** was designed specifically to widen and clean joints and cracks in asphalt and concrete surfaces. **The CRAFCO Model 200** is not intended to be used to clean old sealant from joints and cracks.

CRAFCO, Inc. and its Distributors assume no liability for accident or injury incurred through improper use of this machine.

**DO NOT** operate machine without reading operator's manual and being thoroughly familiar with controls:

1. Check engine crankcase oil. Add oil if low. Refer to Engine Operators Manual.
2. Fill engine gas tank with clean, fresh, unleaded gasoline. See "Fuel Recommendations" in Engine Operators Manual.
3. Check tire inflation. Proper tire inflation is 45 psi. Machine will be difficult to roll with under inflated tires.
4. Check engine cooling air intake and external surfaces of engine. Clean if dirty or obstructed.
5. Check that the air cleaner components and all shrouds, equipment covers, and guards are in place and securely fastened.

# MACHINE START UP

## OPERATING PROCEDURE



### **WARNING: Lethal Exhaust Gases!**

Engine exhaust gases contain poisonous carbon monoxide. Carbon monoxide is odorless, colorless, and can cause death if inhaled. Avoid inhaling exhaust fumes, and never run the engine in a closed building or confined area.

1. Raise the cutter mechanism by moving the toggle switch to the right.
2. Open fuel valve on bottom of fuel tank.
3. Start engine. Refer to page 12-13 for complete engine starting instructions.

**NOTE:** It is recommended that you read the Kohler Owners Manual before starting the engine.

4. Black smoke from the exhaust and a rough running engine usually indicate over-choking.

### **TO CLEAN JOINTS AND CRACKS**

1. Open throttle for maximum engine speed. Position machine over joint and line up pointer with joint. Engage electric clutch by pulling up on “T” handle. Machine is operated by manually guiding the machine while walking backwards. The stabilizer mechanism is designed to stabilize the machine and to act as a brake. Always engage electric clutch before lowering cutter head into the joint.



### **WARNING:**

The Model 200 pavement cutter pushes toward operator when cutting. Tightly compacted surfaces, deep or wide cuts, or hard aggregate may cause sudden machine movement toward operator. This “kickback” could cause operator to lose his balance or control of machine resulting in serious personal injury. When operating, keep wear plate in contact with pavement and hold handle with both hands. For Emergency Stop, push down firmly on machine handle or release safety “T” handle which disengages electric clutch. Push machine handle away.

2. Engage electric clutch by pulling upon “T” handle. Lower cutter head until cutters slightly touch the surface. Notice shade on the depth indicator (Figure 1). Each shade represents approximately 1/4 inch depth variation.
3. **Do not try to go too fast. Do not overload the engine.** Overloading the engine will slow cutting action and cause damage to engine and drive components. A bouncing or hammering action usually indicates the machine is moving too fast or the cutters have worn out of round (refer to Troubleshooting Section, page 26). Let the machine thoroughly clean the joint. For deep cuts (deeper than 3/4 inch) it may be necessary to make two passes. Use brake as required to keep machine under complete operator control. **For emergency stop, push down firmly on handle or release safety “T” handle which disengages electric clutch. Push machine handle away**
4. As cutters wear, depth of cut will change. To compensate for cutter wear, repeat step #2 as often as necessary to reset depth.

5. When cutters will no longer cut to desired depth, they must be replaced. Refer to cutter changing section on Page 22.
6. Governor speed in factor set for the most efficient cutting action. Increasing engine speed may hinder cutter action and also void warranty.

## ENGINE OPERATING INSTRUCTIONS

### Cold Weather Starting Hints

1. Be sure to use the proper engine oil for the temperature expected. See Kohler Owners Manual for recommended SAE Viscosity Grades.
2. Set speed control at part throttle position.
3. A warm battery has much more starting capacity than a cold battery.
4. Use fresh winter grade fuel. **NOTE:** Winter grade gasoline has a higher volatility to improve starting. Do not use gasoline left over from summer.

### Starting

1. **For a Cold Engine:** Place the throttle control midway between the “**slow**” and “**fast**” positions. Place the choke control into the “**on**” position.

**For a Warm Engine (normal operating temperatures):** Place the throttle control midway between the “**slow**” and “**fast**” positions. Place the choke control into the “**on**” position.

2. Start the engine by activating the key switch. Release the switch as soon as the engine starts.

**NOTE:** Do not crank the engine continuously for more than 10 seconds at a time. If the engine does not start, allow a 60 second cool down period between starting attempts. Failure to follow these guidelines can burn out the starter motor.

**NOTE:** Upon start up a metallic ticking may occur. This is caused by the hydraulic lifter leakdown during storage. Run the engine for 5 minutes. The noise will normally cease in the first minute. If noise continues, run the engine at mid throttle for 20 minutes. If noise persists, take the engine to your local Kohler Service outlet.

**NOTE:** If the engine develops sufficient speed to disengage the starter, but does not keep running (a false start), the engine rotation must be allowed to come to a complete stop before attempting to restart the engine. If the starter is engaged while the flywheel is rotating, the starter pinion and flywheel ring gear may clash, resulting in damage to the starter.

If the starter does not turn the engine over, shut off starter immediately. Do not make further attempts to start the engine until the condition is corrected. Do not start using another battery. See your Kohler Engine Service Dealer for trouble analysis.

## ENGINE OPERATING INSTRUCTIONS (Continued)

3. **For a Cold Engine:** Gradually return the choke control to the “off” position after the engine starts and warms up. The engine/equipment may be operated during the warm up period, but it may be necessary to leave the choke partially on until the engine warms up.
4. **For a Warm Engine:** Return the choke to “off” position as soon as engine starts.

### **Stopping**

Place the throttle control midway between the “slow” and “fast” positions. Allow the engine to run a minimum of 15 seconds; then stop the engine.

### **Battery**

A 12 volt battery is used. If the battery charge is not sufficient to crank the engine, recharge the battery.

## **OPERATING**

### **Angle of Operation**

The engine will operate continuously at angles up to 25 degrees. Check oil level to assure crankcase oil level is at the “F” mark on the dipstick. Do not operate the engine continuously at angles exceeding 25 degrees in any direction. Engine damage could result from insufficient lubrication.

### **Cooling**

**NOTE:** If debris builds up on the screen or other cooling air intake areas, stop the engine immediately and clean. Operating the engine with blocked or dirty air intake and cooling areas can cause extensive damage due to overheating.

### **WARNING: Hot Parts!**

Engine components can get extremely hot from operation. To prevent severe burns, do not touch these areas where the engine is running or immediately after it is turned off. Never operate the engine with heat shields or guards removed.

### **Engine Speed**

**NOTE:** Do not tamper with the governor setting in increase the maximum engine speed. Overspeed is hazardous and will void the engine warranty. The high idle speed for this engine is 3750 RPM, no load.

## STORING THE MACHINE

**DO NOT** rest the weight of the machine on the rubber rock deflector or rubber will become deformed making deflector unfunctional. Store with engine in a near level position.

## INSTRUCTION FOR ORDERING PARTS

Parts may be ordered from your local CRAFCO distributor or directly from CRAFCO, Inc. if a distributor is not available in your area. When ordering parts, give the following information:

1. Part Number
2. Machine Model
3. Serial Number from Name Plate

**Write, telephone or fax:**

CRAFCO, INC.  
235 SOUTH HIBBERT  
MESA, AZ 85210  
480-655-8333  
480-655-1712 (FAX)  
Toll Free: 1-800-528-8242

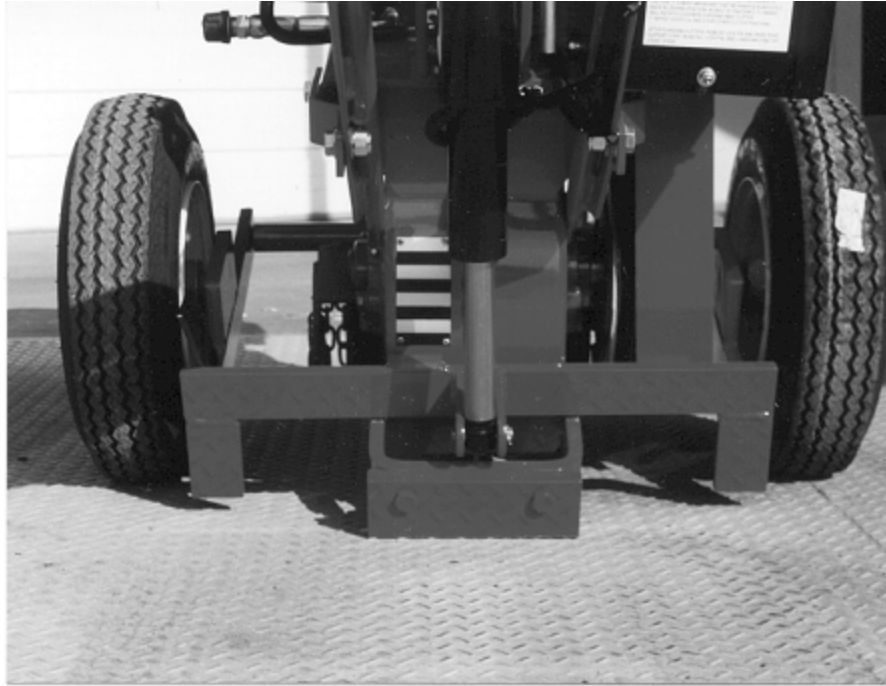

**FIGURE 1**

## **STABILIZER MECHANISM**

A stabilizer mechanism (See Figure 1) is used on the Crafcop Pavement Cutter to improve the stability of the machine and to act as a brake. **TO SLOW OR STOP THE MACHINE, SIMPLY PUSH DOWN ON THE HANDLE.** For normal operation, let wear plate drag on paved surface while machine is in operation.

Wear plate (Part No. 31065) should be replaced before wear reaches the attaching bar.

# MAINTENANCE

## Oil Recommendations:

Using the proper type and weight of oil in the crankcase is extremely important. So is checking oil daily and changing oil regularly. Failure to use the correct oil, or using dirty oil, causes premature engine wear and failure.

## Oil Type:

Use high quality detergent oil of API (American Petroleum Institute) service class SG or SH. Select the viscosity based on the air temperature at the time of operation as shown in the following table.

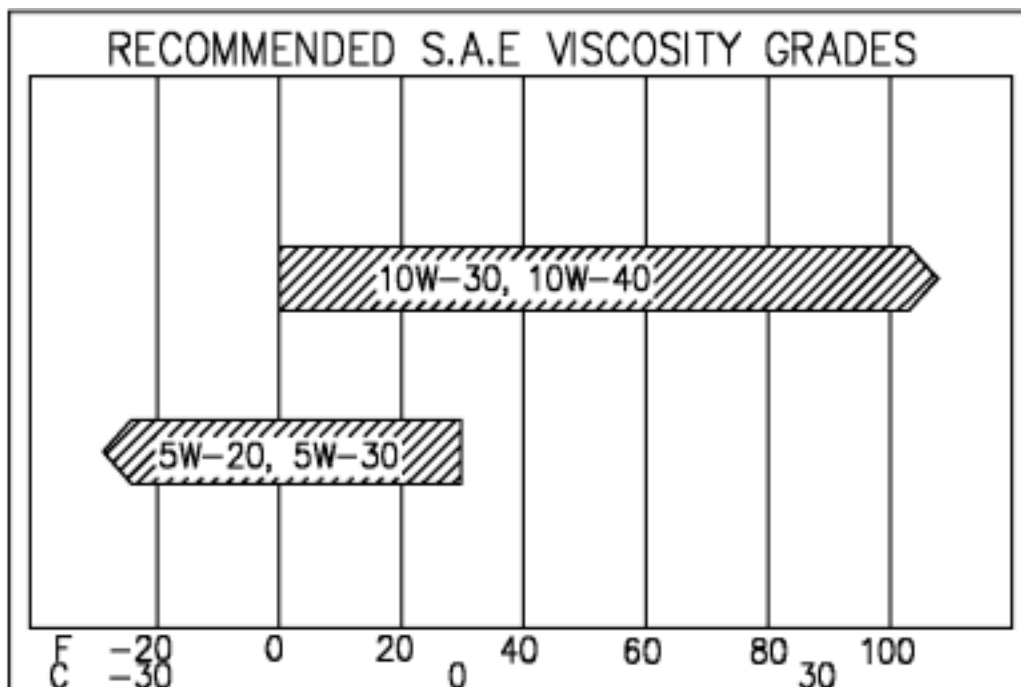

## NOTE:

Using other than service class SG or SH oil or extending oil change intervals longer than recommended can cause engine damage. Refer to the Maintenance instructions on page 22 or the [Kohler Owners Manual](#) for detailed oil check, oil change, and oil filter change procedures and intervals.

## Fuel Recommendations:

### **WARNING: Explosive Fuel!**

Gasoline is extremely flammable and its vapors can explode if ignited. Store gasoline only in approved containers, in well ventilated, unoccupied buildings away from sparks or flames. Do not fill the fuel tank while the engine is hot or running, since spilled fuel could ignite if it comes in contact with hot parts or sparks from ignition. Do not start the engine near spilled fuel. Never use gasoline as a cleaning agent.



# MAINTENANCE (Continued)

## **General Recommendations:**

Purchase gasoline in small quantities and store in clean, approved containers. A container with a capacity of 2 gallons or less with a pouring spout is recommended. Such a container is easier to handle and helps eliminate spillage during refueling.

To minimize gum deposits in your fuel system and to insure easy starting. Do not use gasoline left over from the previous season.

Do not add oil to the gasoline.

Do not overfill the fuel tank. Leave room for the fuel to expand.

## **Fuel Type:**

For best results use only clean, fresh, unleaded gasoline with a pump sticker octane rating of 87 or higher. In countries using the Research method, it should be 90 octane minimum.

Unleaded gasoline is recommended as it leaves less combustion chamber deposits. Leaded gasoline may be used in areas where unleaded is not available and exhaust emissions are not regulated. Be aware, however, that the cylinder heads may require more frequent service.

## **Gasoline/Alcohol Blends:**

Gasoline (up to 10% ethyl alcohol, 90% unleaded gasoline by volume) is approved as a fuel for Kohler engines. Other gasoline/alcohol blends are not approved.

## **Gasoline/Ether Blends:**

Methyl Tertiary Butyl Ether (MTBE) and unleaded gasoline blends (up to maximum of 15% MTBE by volume) are approved as a fuel for Kohler engines. Other gasoline/ether blends are not approved.

## **BATTERY**

Check charge condition. Check electrolyte level. Add distilled water to keep electrolyte at its proper level. In freezing weather, run engine immediately after adding water. Keep battery connections tight and clean.

## **WARNING: Explosive Gas!**

Batteries produce explosive hydrogen gas while being charged. To prevent a fire or explosive, charge batteries only in well ventilated areas. Keep sparks, open flames, and other sources of ignition away from the battery at all times. Keep batteries out of the reach of children. Remove all jewelry when servicing battery.

## PERIODIC MAINTENANCE

Follow a regular schedule of inspection and servicing, based on operating hours. Keep an accurate logbook of maintenance, servicing, and operating time. Use the factory recommended Periodic Maintenance Schedule (based on favorable operating conditions) to serve as a guide to get long and efficient engine life.

For severe duty, extreme temperature, etc., service more frequently. Neglecting routine maintenance can result in engine failure or permanent damage.

For any abnormalities in operation, unusual noises from the engine or accessories, loss of power, overheating, etc., contact your nearest Kohler Service Center.



### WARNING:

Inhalation of exhaust gases can result in serious personal injury or death. **DO NOT** use the air cleaner or exhaust elbow as a supporting step. Damage of these and connecting parts might cause an exhaust leak.



### WARNING: Accidental Starts!

Before servicing the engine or equipment on the machine, always disconnect the spark plug leads to prevent the engine from starting accidentally. Ground the leads to prevent sparks that could cause fires.

# MAINTENANCE SCHEDULE

These required maintenance procedures should be performed at the frequency stated in the chart below. They should also be included as part of any seasonal tune-up.

<b>FREQUENCY</b>	<b>MAINTENANCE REQUIRED</b>
Daily or before starting engine	Fill fuel tank. Check oil level. *Check air cleaner for dirty, loose or damaged parts. *Check air intake and cooling areas, clean as necessary. Grease drum shaft bearings. Blow loose dust/dirt off engine.
Every 25 hours	*Service pre-cleaner dust cap. Check Battery Electrolyte Level. *Service primary air cleaner element.
Every 100 hours	Change oil. *Remove cooling shrouds, and clean cooling areas. Check oil cooler fins, clean as necessary. Check spark plug condition and gap if necessary.
Every 200 hours	Change oil filter. *Check secondary air cleaner element and foam wrap.
Annually or every 500 hours.	**Have UTE bendix starter drive serviced. **Have solenoid shift starter disassembled and cleaned. Repack wheel bearings.

# SERVICE AND MAINTENANCE INSTRUCTIONS

For longer engine life the Model 200 has been fitted with a High Capacity Air Cleaner (primary) and secondary element. Due to the dusty conditions created during operation, it is necessary to service the air cleaner when it becomes clogged with dirt.

To change the primary air cleaner element, loosen the clamp and remove the air cleaner cap.

1. Service element only when restriction indicator reaches the service level (indicator pops up). It is only above that point that air cleaner restriction begins to reduce engine performance level. When restriction finally indicates a change, remove the primary element carefully. When element replacement is needed use Crafcro 31334 (Kohler 25-083-01)
2. Do not attempt to clean the dirty element. Rapping, or pounding dirt out is dangerous and could cause damage to the element.
3. Carefully check new element for damage before installing.
4. Reinstall new element, replace air cleaner cap and fasten retaining clips.

Check the secondary element (safety) only if the primary air cleaner element was damaged.

1. Remove the air cleaner cover.
2. Remove the primary element.
3. Remove the safety element
4. Handle new elements carefully: do not use if the sealing surfaces are bent or damaged.
5. Reinstall the new safety element, primary element and air cleaner cap. Fasten retaining clips
6. When element replacement is necessary, order Crafcro P/N 31345 (Kohler 25-083-04)

Check engine oil daily. Change oil after every 100 hours of operation. Change oil filter every 200 hours. Use Crafcro P/N 31330 or Kohler P/N 12-050-01. (Refer to engine owners manual).

Check fluid level in battery regularly.

Every 50 hours of operation clean out cooling fins on engine. If dust is allowed to accumulate overheating may occur, causing damage to the engine.

Lubricate cutter shaft bearings every 100 hours using multi-purpose grease.

Lubricate frame pivot every 50 hours using multi-purpose grease.

Tighten all bolts on machine frequently.

# SERVICE AND MAINTENANCE INSTRUCTIONS (CONT'D)

After 2 hours of operation check and tighten the V-belts as required. To tighten belts, adjust jam nuts under engine mount. (Refer to Figure 3)

	<p><b>CAUTION:</b> Do not overtighten belts as damage will occur to belts and bearings. Belts that are too loose will shorten the life of the belts and sheaves. Recheck belt tension after 8 hours and every 40 hours thereafter. When installing new belts do not attempt to stretch over sheaves. Always replace both belts and inspect sheaves for wear.</p>
---	--

Clean machine each day using compressed air or by wiping with rags, especially in area of engine cooling fins.

Periodically inspect the in-line fuel filter and replace when dirty. Use Crafcó P/N 31331 of Kohler P/N 25-050-03.

Always use genuine Crafcó cutters and other replacement parts. Failure to do so will void warranty and possibly cause damage to machine or injury to operator.

# CHANGING CUTTERS

The procedure outlined below will greatly simplify cutter changing.



## **WARNING:**

**ENGINE MUST NOT BE RUNNING WHEN CHANGING CUTTERS OR WORKING ON ANY PART OF MACHINE. SERIOUS INJURY OR DEATH COULD RESULT. DO NOT ALLOW ANYONE TO PULL ON HANDLE, START ENGINE, OR DO ANY OTHER MAINTENANCE WHILE WORKING ON CUTTER HEAD.**

1. Raise cutter mechanism to maximum height. Push machine forward while holding handle up. This will allow rock deflector to fold up and machine to tilt forward exposing cutters for easy accessibility. Make sure front stand is supporting machine before releasing handle. (Figure 2)
2. Remove click pin on rear stand, lower support strip, and reinstall click pin to lock strip in place. (Figure 3)
3. Place wrench supplied with machine on exposed bolt in cutter window. (See Figure 3). Turn clockwise to rotate cutter head to end of cutter window. This will rotate cutter head for proper indexing. Do not attempt to turn cutter head with hands.
4. Remove wrench and place on bolt just exposed. Loosen bolt at least one full turn. Slide retainer back exposing pin.
5. Using pin removal tool (also supplied with machine) push pin all the way out, except when changing pins. Remove worn cutters and/or worn pins. Pins should be replaced when worn in any area to a diameter less than 3/4 inch. Use pin as a pilot to mount spacers and cutters. Make sure carbide tips are positioned per Cutter Installation Warning page 30
6. Slide retainer back into position and tighten bolt.



## **CAUTION:**

It is most important that retainer is always put back in the locked position. As bolt is tightened, flywheel will rotate clockwise exposing next cutter.

7. Repeat steps 3, 4 and 5 for other five cutter positions.
8. Remove click pin from rear stand, move support strip to upper position and reinstall click pin.
9. Lower machine to operating position.

See page 30-32 for cutter configurations. Call Crafcro or your local Crafcro Distributor for any additional questions you may have.

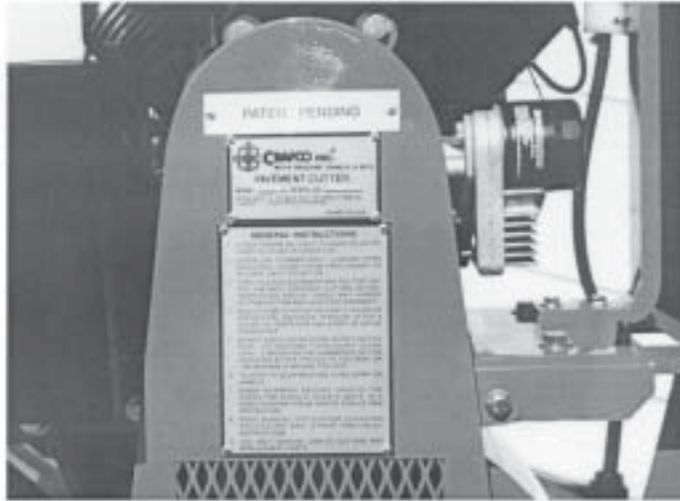

**FIGURE 2**

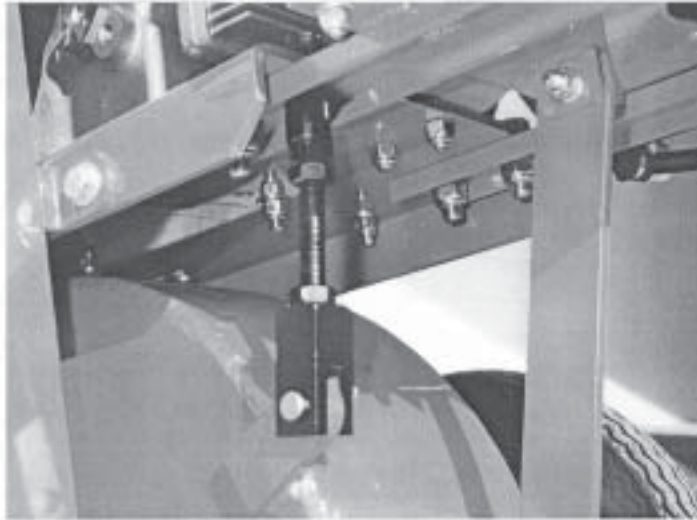

**FIGURE 3**

# INSTALLING NEW CUTTER HEAD AND MAIN SHAFT

The cutter head and main shaft are sold in matched sets and must be installed together.

1. Slip the bearings on to the main shaft in the new cutter head.
2. Push the handle down all the way to the ground to raise the front of machine.
3. Roll new cutter head assembly under machine and into position.
4. Line up bearings with cutout sections in the flywheel housing, fitting each into its slot as machine is lowered over flywheel.
5. Reinstall three cap screws that attach bearings to flywheel housing.
6. Center cutter head in housing and move main shaft so that it is flush with bearing on side opposite sheaves.
7. Replace locking ring mechanism on each bearing (if equipped).
8. If bearings do not use a locking ring, follow this procedure: Using 1/4" electric drill and 13/64" drill bit, make dimple in shaft under one or more set screws. Remove two set screws on each bearing and coat with a thread adhesive such as Loctite. Replace set screws and tighten until snug.
9. Reinstall hub and lower sheave. Be sure the sheaves are in alignment using straight edge.
10. Tighten cap screws that pull the sheave onto bushing alternately and progressively until tapers are seated. Check alignment and sheave run out or wobble and correct as necessary before tightening cap screws to recommended torque value of 9 ft. - lbs. each.
11. Reinstall wheel and tire assemblies.
12. Install V-belts and tighten tension using the jam nuts underneath motor mount. Correct belt tension is 1/4" deflection per belt when 10 lbs. pressure is applied.
13. Install belt guard.
14. Install cutters, shafts and spacers as outlined in changing cutters, page 22.



# CHANGING CUTTER HEADS

It is recommended that the cutter head be changed when holes for pins are worn to 1.000 diameter or larger.

## REMOVING OLD CUTTER HEAD AND MAIN SHAFT

1. Remove belt guard. (See Figure 2)
2. Back off belt tension adjusting bolt jam nuts all the way and remove the V-belts. (See Figure 3).
3. Tip machine back lowering handle all the way to the ground.
4. Remove wheels.
5. Remove lower sheave. The sheave has a built in puller. Loosen and remove the three mounting cap screws. Insert these same cap screws in the threaded jack-screw holes. Starting with the screw farthest from the bushing saw slot; tighten all screws alternately and progressively to separate sheave from bushing.
6. Drive a wedge into the slot of bushing, barely enough to free the bushing and slide bushing off shaft.
7. Lift handle to set machine flat on ground, then remove top three cap screws in each of the two main shaft bearings. It is not necessary to remove bottom cap screw in each bearing but leave it intact.
8. Push handle down all the way to the ground again. This will lift front of machine free of cutter head assembly and complete assembly can be rolled out to clean machine.

## CHANGING V-BELTS

1. Remove belt guard by removing 4 bolts. (See Figure 2).
2. Loosen belt tensioner until bottomed out. (See Figure 3).
3. Remove old belts. Install new belts.
4. Tighten belt tensioner. Correct tension is 1/4" deflection per belt when 10 lbs. pressure is applied. Incorrect belt tension will cause poor belt life, damage to bearings, and engine crankshaft bushing failure.
5. Install belt guard.

## ELECTRIC CLUTCH

The Model 200 is equipped with an electric clutch which can be engaged independently of engine operation. Under normal operation, no service of this clutch is required. If the V-grooves should become worn, a completely new clutch assembly (31289) must be installed.

## TROUBLE-SHOOTING GUIDE

PROBLEM	CAUSE	REMEDY
Cutters wear out of round.	Cutters not spinning on pins thereby creating uneven wear.	Take deeper cut. Work machine harder causing cutters to spin on pins.
Engine stalls.	No spark.	Check electric system for defective wires, switches, etc.
	Inadequate supply of fuel to carburetor.	Check fuel pump, fuel valve and lines.
Machine fails to raise or lower.	Damaged switch, wiring, or fuse.	Replace defective components.
	Defective worn linear actuator.	Replace linear actuator.
Engine doesn't spin properly when cranking.	Starter problems.	Repair or replace starter.
	Low battery.	Charge or replace battery.
Engine missing, loss of power.	Dirty carburetor.	Clean carburetor.
	Defective fuel pump.	Replace fuel pump.



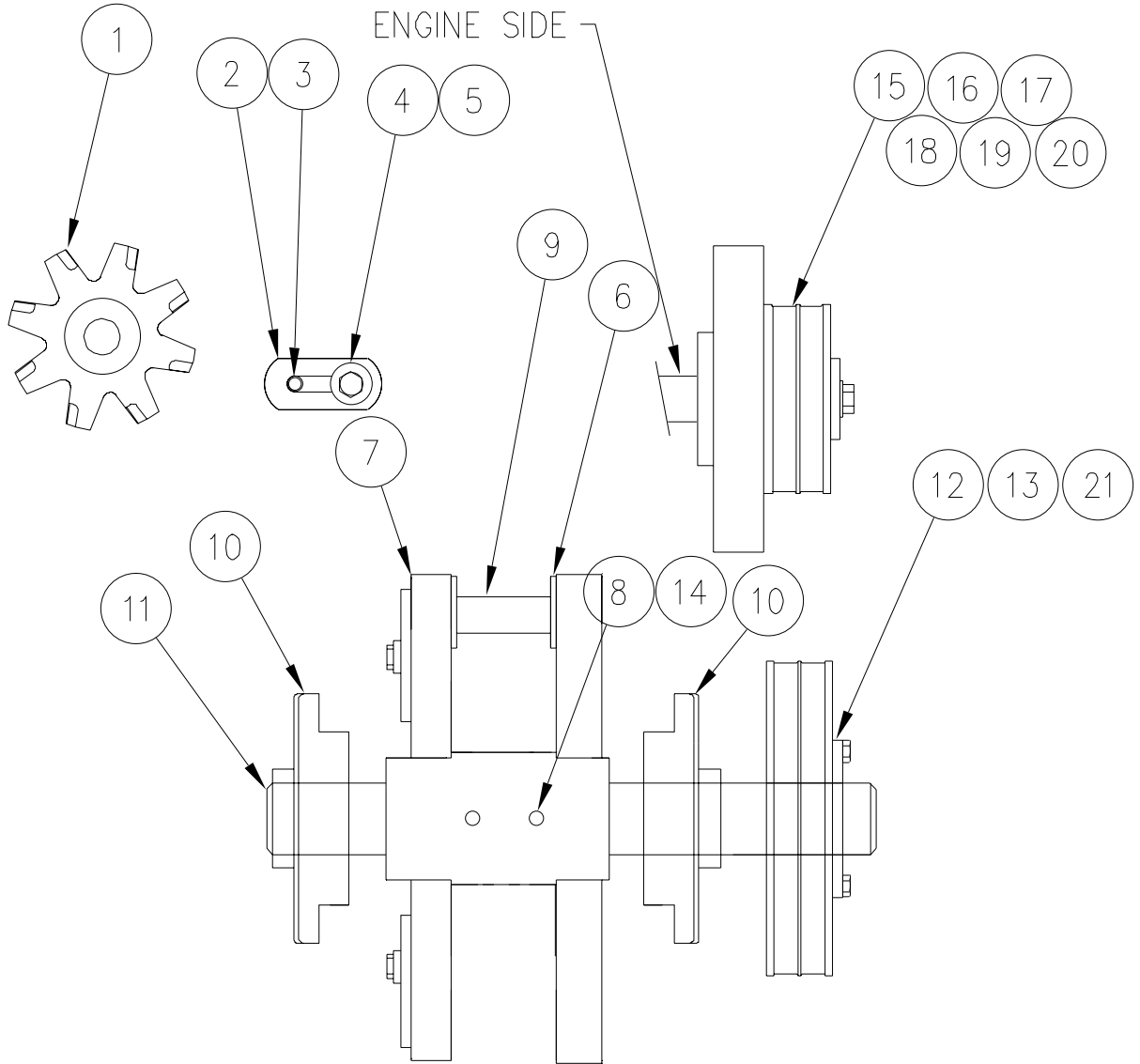



# CUTTER HEAD ASSEMBLY COMPLETE-PART NUMBER 26576PB



### CUTTER HEAD ASSEMBLY PARTS LIST

NUMBER	PART NUMBER	QTY	DESCRIPTION
1	31145	6	WIDE HUB CARBIDE TIPPED CUTTER
2	31120	6	RETAINING TAB
3	32061	6	3/8 X 3/4 ROLL PIN
4	32039	6	3/8"-16 X 3/4" BOLT
5	28672	6	3/8" FLAT WASHER
6	--	--	NOT USED
7	31032	1	CUTTER HEAD
8	28847	2	1/2 SQ HED SET SCREW
9	31114	6	CUTTER PIN
10	32043	2	BEARING
11	31073	1	MAIN SHAFT
12	32072	1	SHEAVE
13	32071	1	1 3/4 BUSHING
14	31072	1	KEY- 3/8 X 4
15	31289	1	ELECTRIC CLUTCH
16	31004	1	KEY, 1/4 X 2 3/4
17	28897	1	BOLT, 7/16 X 1 1/4
18	28684	1	WASHER
19	28688	1	WASHER (NEXT TO ENGINE)
20	28688	1	WASHER (NEXT TO CLUTCH)
21	31071	1	3/8 SQ KEY X 1 5/8 LONG

## PAVEMENT CUTTER SELECTION

<p>31134 Standard Steel Standard Hub</p>		<p>PCC Pavement AC Pavement</p>	<p>Cast steel cutter for use with 12 hardened steel spacers. Able to be configured to cut 1/2" wide to 1 1/2" wide. (See Figure 10)</p>
<p>31136-7 Carbide Tip Standard Hub</p>		<p>AC Pavement</p>	<p>Cast Steel Cutter with a Carbide insert cutting surface. For use with 12 hardened steel spacers. Able to configure to cut 1/2" to 1 1/2" wide. (See Figure 10)</p>
<p>31149 Carbide Tip Standard Hub Extended Life</p>		<p>AC Pavement</p>	<p>Hardened Cast Steel Cutter with a Carbide insert cutting surface for extended cutting life. For use with 12 hardened steel spacers. Able to configure to cut 1/2 to 1 1/2" wide. (See Figure 10)</p>
<p>31135 Carbide Tip Shaved cutter</p>		<p>AC Pavement</p>	<p>Cast Steel Cutter with a Carbide insert cutting surface. Hub removed to allow the cutter to be stacked for wider cuts. For use with hardened steel spacers. Able to be configured to cut 1/2 to 2" wide. (See Figure 11)</p>
<p>31145 Carbide Tip Wide Hub (patent pending)</p>		<p>AC Pavement</p>	<p>Cast Steel Cutter with a Carbide insert cutting surface. For use with 2 hardened steel spacers. Able to be configured to cut 1/2" to 3/4" wide. Designed to provide a cleaner cut. (See Figure 12)</p>
<p>31138 Carbide Tip Extra Long</p>		<p>AC Pavement</p>	<p>Cast Steel Cutter with a Carbide insert cutting surface. with longer teeth for cutting depth up to 2". For use with 12 hardened steel spacers. Able to be configured to cut 1/2 to 1 1/2" wide. (See Figure 13)</p>

## CUTTER INSTALLATION WARNING



### WARNING

Install replacement cutters as shown. Failure to install correctly will result in rapid deterioration of carbide tip.

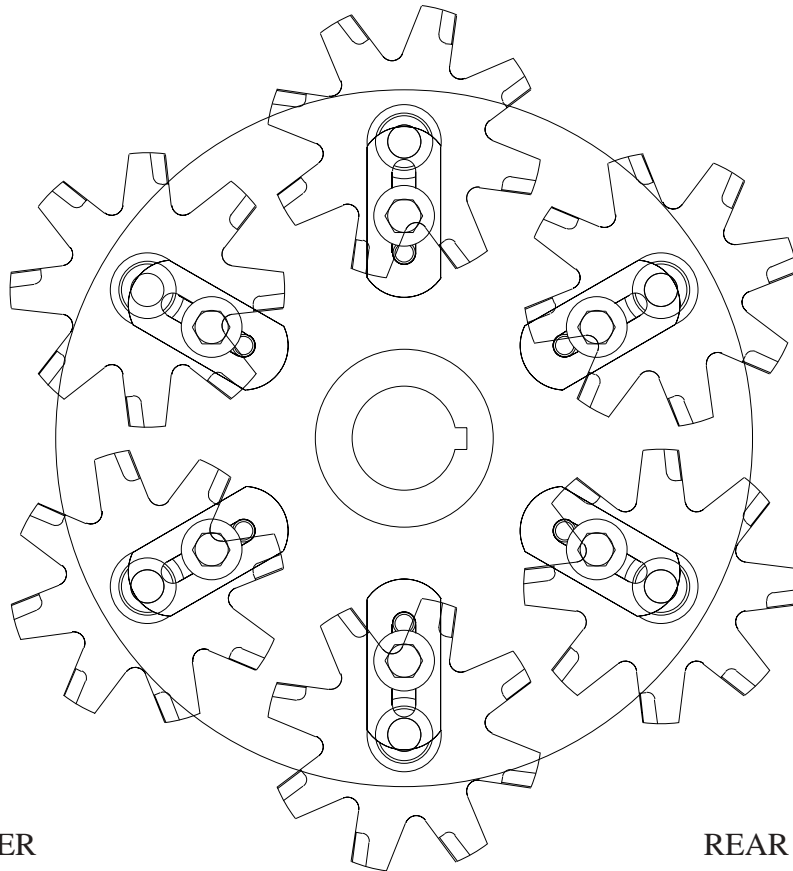

FRONT OF ROUTER

REAR OF ROUTER

**Figure 10**

Cutter Positioning for Part Number  
31134, 31136-7, 31149

Cutters can be aligned or staggered to configure the desired cut width. For wider cutting additional cutters can be added to a single pin to achieve a smoother finished cut. Always use enough Hardened Spacers to keep cutters appropriately positioned on the pin while still allowing the cutter to turn completely free..

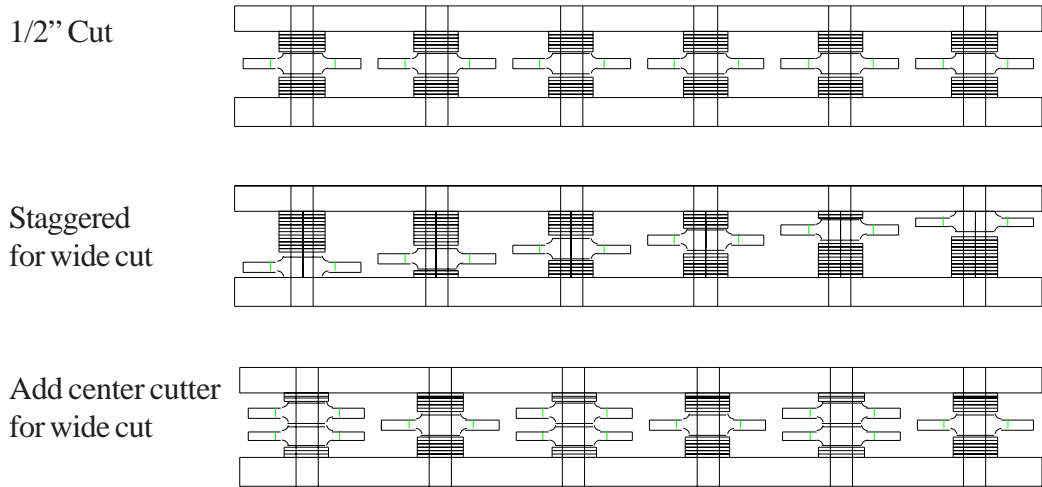

**Figure 11**

Cutter Positioning for Part Number  
31135 Shaved Cutter

Cutters can be aligned to configure the desired cut width. For wider cutting additional cutters can be added to a single pin to achieve a smoother finished cut. Always use enough Hardened Spacers to keep cutters appropriately positioned on the pin while still allowing the cutter to turn completely free. The main consideration is placing equal number of cutters and spacers on opposite pins to maintain balance. Failure to do so could result in permanent damage to the machine and possible injury to the operator.

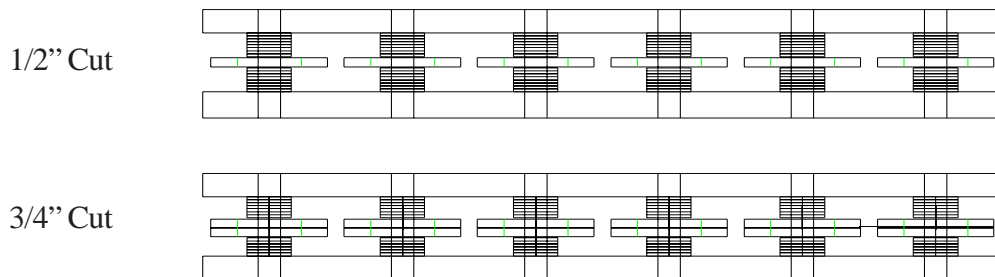

**Figure 12**  
 Cutter Positioning for Part Number  
 31145(patent pending)

Cutters can be aligned or staggered to configure the desired cut width. Two Hardened Spacers are used with this cutter. Cutter produces a cleaner cut and less cutter bore wear.

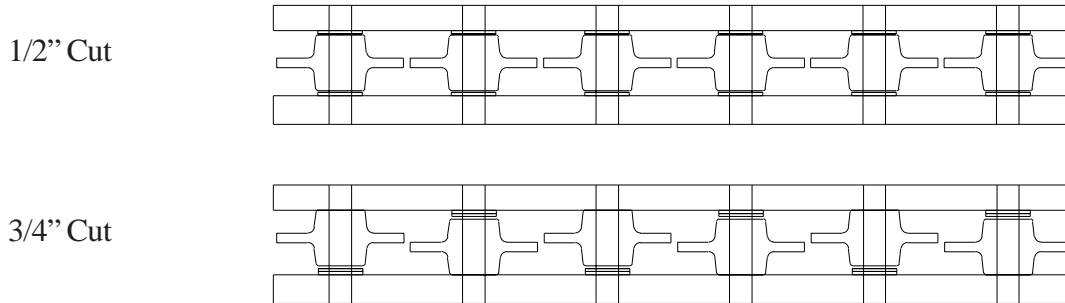

**Figure13**  
 Cutter Positioning for Part Number  
 31138- 6 1/2" Cutter

Cutters can be aligned or staggered to configure the desired cut width. For wider cutting additional cutters can be added to a single pin to achieve a smoother finished cut. Always use enough Hardened Spacers to keep cutters appropriately positioned on the pin while still allowing the cutter to turn completely free.

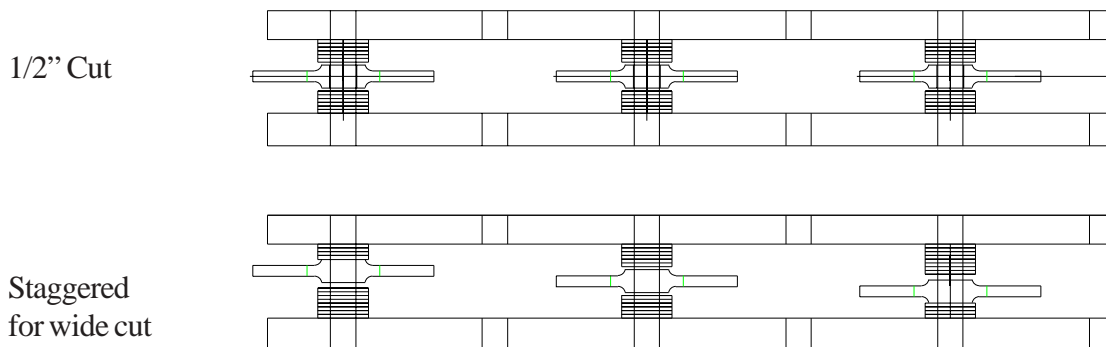



# MODEL 200 PAVEMENT CUTTER - 20990PB

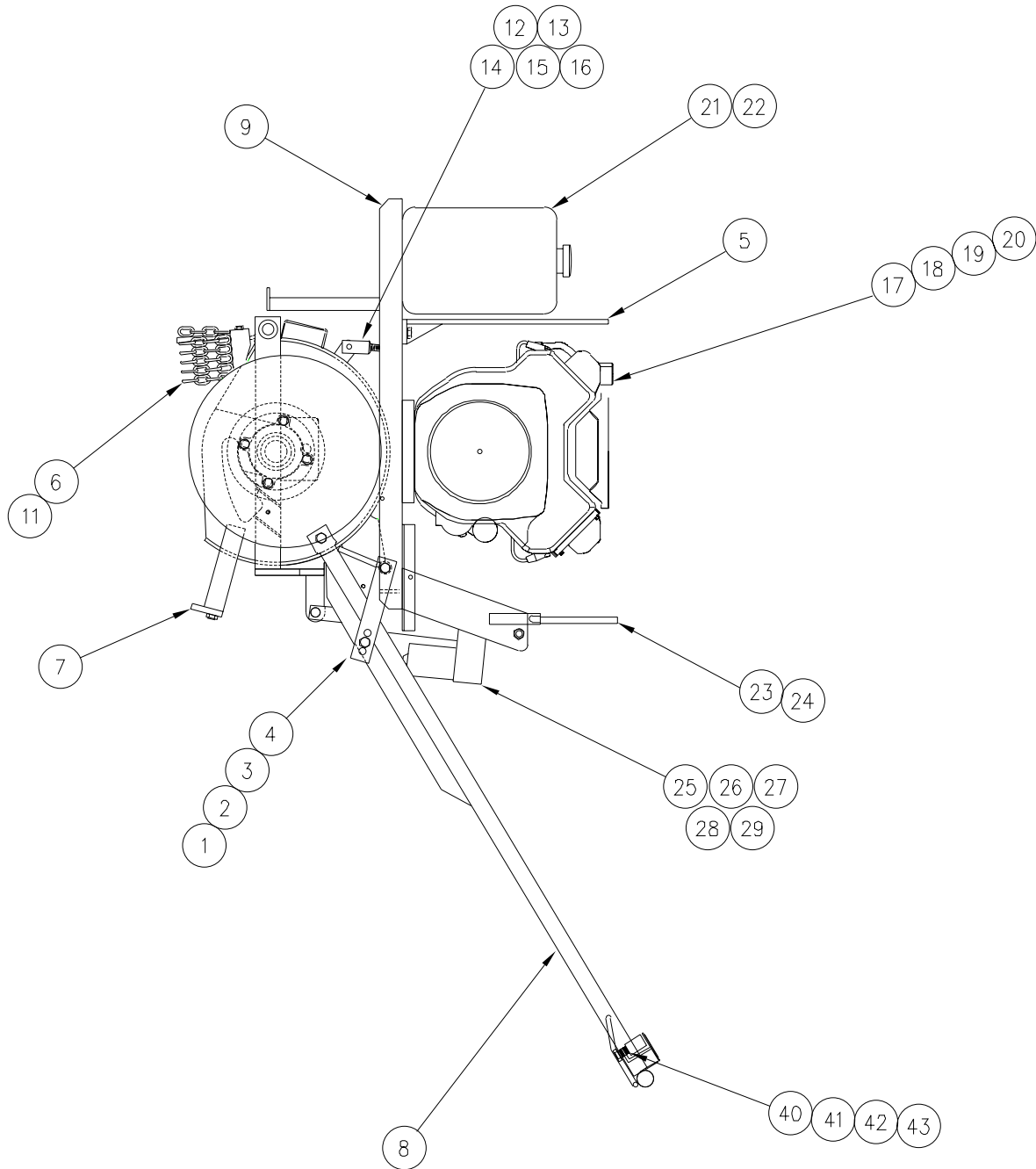

# MODEL 200 PAVEMENT CUTTER - 20990 PB1

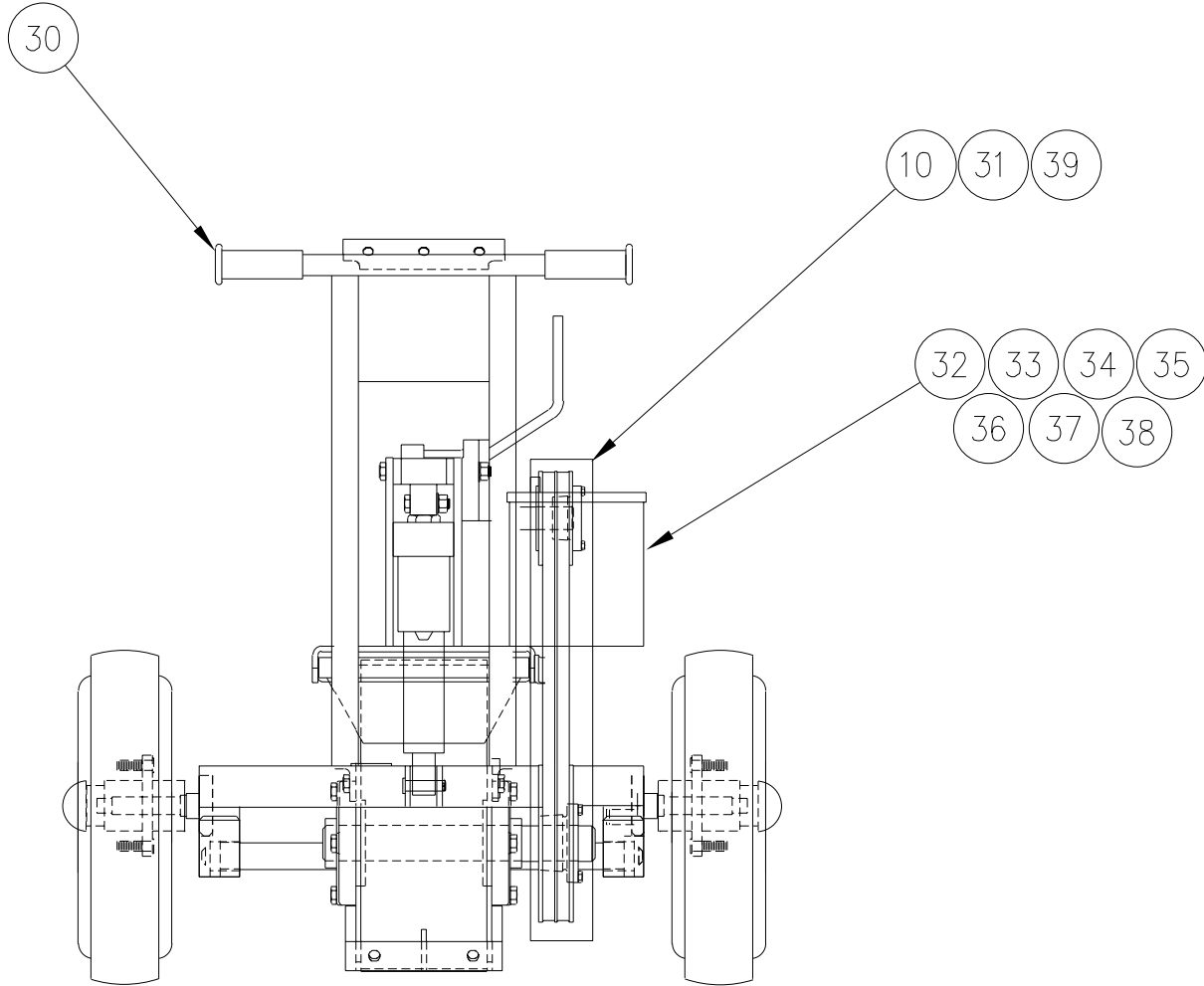

### 25 HP ROUTER - PARTS LIST

NUMBER	PART NUMBER	QTY.	DESCRIPTION
1	31210	2	HANDLE BRACKET
2	28759	2	1/2 X 1-1/4 GRADE 8 BOLT
3	28528	2	1/2 ESNA NUT
4	28642	4	HARDENED WASHER
5	32199	1	LIFTING BRACKET ASSEMBLY
6	31104	1	DEFLECTOR CHAIN ASSEMBLY
7	31065	1	STABILIZER WEAR PLATE
8	31060	1	ROUTER HANDLE ASSEMBLY
9	32190	1	ENGINE MOUNTING PLATE ASSEMBLY
10	31283	1	BELT GUARD
11	31102	1	RUBBER ROCK DEFLECTOR
12	29638	1	COTTER PIN
13	31052	1	CLEVIS PIN
14	31211	1	SPACER
15	28516	2	1/2 JAM NUT
16	29345	1	CLEVIS PIN
17	31292	1	25 HP ENGINE
18	29803	1	ADAPTER FITTING
19	AX6-8FJ9-8MP-6.75	1	DRAIN HOSE
20	28268	1	PIPE CAP
21	31293	1	FUEL TANK
22	31266	2	FUEL TANK STRAP
23	31100	1	PIN REMOVAL TOOL
24	31101	1	PIN RETAINING WRENCH
25	32001	1	ACTUATOR

## 25 HP ROUTER - PARTS LIST

NUMBER	PART NUMBER	QTY.	DESCRIPTION
26	32109	2	RUBBER BUSHING
27	31068	1	SHOCK ABSORBER
28	29345	1	1/2 X 2 CLEVIS PIN
29	29638	1	COTTER PIN
30	32081	2	HANDLE GRIP
31	32078	2	BELT 5VX-560
32	32547	1	12 VOLT BATTERY GROUP 26
33	32602	1	CABLE/BATTERY CAP - BLACK-24187
34	24054	1	CABLE/BAT. CAP - RED-24186
35	31335	1	BATTERY BOX SIDE
36	31336	1	BATTERY BOX TOP
37	32602	1	BATTERY CABLE - BLACK (20")
38	24054	1	BATTERY CABLE - RED (20")
39	32182	1	MUFFLER SUPPORT
40	31340	1	HANDLE STOP
41	31338	1	SWITCH
42	28685	1	STAR WASHER
43	31506	1	WIRING HARNESS



---

---

**Pioneering Leadership and  
Innovation in Quality  
Pavement Maintenance  
Materials.**



**235 South Hibbert • Mesa, Arizona 85210  
480-655-8333 • Watts 1-800-528-8242  
Fax 480-655-1712**

©Copyright 1999 by Crafco, Inc.