



SUPER SHOT 60 MELTER

PART MANUAL - 26616

REV. A

Revised: 11/12

SUPER SHOT 60 MELTER



TABLE OF CONTENTS

Super Shot 60 Melter.....	5
Safety Precautions.....	6-7
Limited Warranty.....	7
Warranty Claim Instructions.....	8
Specifications.....	9
Introduction.....	10
Operating Instructions	
Machine Start Up.....	11-12
Dispensing the Material.....	12-13
Active Pump Protection.....	13
Loading the Machine/Shutdown and Clean-Out Procedure/Storing Machine.....	14
Instructions For Ordering Parts/Electric Hose Care and Cautions.....	15
Hose Transport Instructions.....	16
Maintenance	
Maintenance Instructions.....	17
Maintenance Chart/Service Instructions.....	18
Recommended Fluids and Lubricants/Typical Specifications.....	19
Super Shot Pump Replacement	20
Super Shot Pump Replacement Diagram.....	21
Trouble Shooting	
Trouble Shooting Guide - Hose Does Not Heat.....	22
Hose Circuit Diagram.....	23
Trouble Shooting Guide - Hose Does Not Heat.....	24
Trouble Shooting Guide - Material Does Not Dispense When Pump is Activated.....	24
Hose Circuit Diagram.....	25
Trouble Shooting Guide - Material Does Not Dispense When Pump is Activated.....	26
Trouble Shooting Guide - Pump Rotates But No Material is Discharged.....	26
Trouble Shooting Guide - Material Dispensing Rate is Too Slow.....	26
RTD Sensor-OHMS vs. Temperature.....	27
Burner Schematic.....	28
Burner Trouble Shooting.....	29
Trouble Shooting Hydraulics.....	30
Hydraulic Schematic Diagram.....	31
Parts	
Super Shot 60 Melter Assembly Diagram and Parts.....	32-35
Tank Detail Diagram and Parts.....	36-37
Control Box Assembly Diagram and Parts.....	38-39
Gas Manifold Assembly Diagram and Parts.....	40-41
Power-Pack Assembly Diagram and Parts.....	42-43
Hydraulic Valve Assembly.....	44
Pump/Agitator Assembly.....	45
Burner Assembly.....	46-47
Hydraulic Diagram and Parts.....	48-49
LPG Schematic and Parts.....	50-51
Electrical Schematic and Parts.....	52-53
Optional Shot Timer Electrical Schematic	54-55

SUPER SHOT 60 MELTER

This manual is furnished with each new **CRAFCO SUPER SHOT 60 MELTER**. This manual will help your machine operators learn to run the melter applicator properly and understand its mechanical functions for trouble-free operation.

Your **CRAFCO SUPER SHOT 60 MELTER** is designed to give excellent service and save maintenance expense. However, as with all specially engineered equipment, you can get best results at minimum costs if:

1. You operate your machine as instructed in this manual.
2. Maintain your machine regularly as stated in this manual.

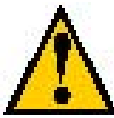

WARNING: The engine exhaust from this product contains chemicals known to the State of California to cause cancer, birth defects or other reproductive harm. Operate in well ventilated area only. Engine exhaust is deadly.

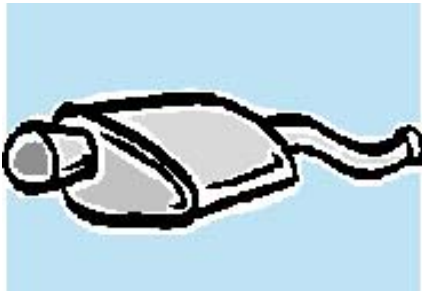

SAFETY PRECAUTIONS

- High operating temperatures of sealant and machine require protective clothing, hard soled shoes and heat resistant gloves to be worn by operator.

- Always wear eye protection.



- Observe all **CAUTION AND WARNING** signs posted on machine.



- Avoid the entrance of water into any part of the machine. Water will displace heat transfer oil or sealant, which could be hazardous to personnel surrounding the machine when it reaches operating temperatures.

- Avoid bodily contact with hot sealant material or heat transfer oil, serious burns may result.

- Read Operator Manual thoroughly before operating machine.

- Make sure operator is familiar with machine operation.

- Do not operate in closed building or confined areas.

- Shut-down burner and engine prior to refilling diesel tank.

- When adding solid material to sealant tank, stop mixer, lift lid, place material onto lid and close lid before restarting mixer. Hot material could splash and cause serious burns if this procedure is not followed.

- Keep hands, feet, and clothing away from all moving parts.

- Always keep a fire extinguisher near the unit. Maintain extinguisher properly and be familiar with its use.



- **DO NOT** exceed 525° F for heat transfer oil temperature.

- **DO NOT** overfill heat transfer oil level. Expansion of oil during heat up could cause overflow. With machine in level position, check oil each day before starting burner, add oil to top mark on dipstick if required (at 70° F). **Use only recommended heat transfer oil and change after 500 hours of operation or one year, whichever occurs first.**

- Follow operating instructions for starting and shut-down of burner. Instructions are mounted on control box.

- Calibrate temperature control prior to initial operation and each 50 hours of operation.

SAFETY PRECAUTIONS

- Replace any hoses which show signs of wear, fraying, or splitting. Be sure all fittings and joints are tight and leak-proof.
- Precaution is the best insurance against accidents.
- The Super Shot 60 Melter should not be left unattended with burner lit.
- Tighten all bolts and screws after every 100 hours of operation.
- Crafco, Inc. assumes no liability for an accident or injury incurred through improper use of the machine.



LIMITED WARRANTY

Crafco, Inc., through its authorized distributor, will replace for the original purchaser free of charge any parts found upon examination by the factory at Mesa, Arizona, to be defective in material or workmanship. This warranty is for a period within 60 days of purchase date, but excludes engine or components, tires, and battery as these items are subject to warranties issued by their manufacturers.

After 60 days, Crafco, Inc., warrants structural parts, excluding heating system, hydraulic components, material pump and hoses, hot oil pump, applicator valves, and electrical components for a period of (1) one year from date of delivery. Crafco, Inc., shall not be liable for parts that have been damaged by accident, alteration, abuse, improper lubrication/maintenance, normal wear, or other cause beyond our control.

The warranty provided herein extends only to the repair and/or replacement of those components on the equipment covered above and does not cover **labor** costs. The warranty does not extend to incidental or consequential damages incurred as a result of any defect covered by this warranty.

All transportation and labor costs incurred by the purchaser in submitting or repairing covered components must be borne by the purchaser.

Crafco, Inc. specifically disavows any other representation, warranty, or liability related to the condition or use of the product.



WARNING: Use of replacement parts other than genuine Crafco parts may impair the safety or reliability of your equipment and nullifies any warranty.

WARRANTY CLAIM INSTRUCTIONS

Please follow the instructions stated below when calling in a Warranty Claim. Failure to follow these procedures may be cause to void the warranty.

1. Call your local CrafcO distributor. If you do not know who your local distributor is, call a CrafcO Customer Service Representative, (Toll Free 1-800-528-8242) for name, location, and telephone number.
2. On contacting the distributor, be prepared to identify the machine type, model number, and serial number, also, the date of purchase if available.
3. Should the cause of the malfunction be a defective part, the distributor will advise you of the procedure to follow for a replacement.
4. The warranty is valid only for parts, which have been supplied or recommended by CrafcO, Inc.

If you have any additional questions regarding warranty repairs and parts, please do not hesitate to call toll free 1-800-528-8242.

CRAFCO, INCORPORATED
25527 S. ARIZONA AVE.
CHANDLER, AZ 85249
480-655-8333
Toll Free 1-800-528-8242

SPECIFICATIONS

Vat Capacity.....	60 Gallons
Melt Capacity.....	40 Gallons/Hour
Heat Transfer Oil Required.....	21 Gallons at 70° F
Tank Construction.....	Double Boiler Type
Tank Opening Size.....	12" X 15"
Maximum Heat Input.....	Vapor Burner 180,000 BTU's
Burner and Temperature Control.....	Automatic - Fail Safe
Engine - Kohler.....	Single Cylinder
Model CH-20 - Propane Fueled	17.1 BHP @ 3,600 rpm
Drive Mechanism.....	All hydraulic with infinite speed on mixer and material pump.
Mixer.....	Full sweep mixer with two horizontal paddles.
Axle.....	Single - 2,000 lb. Capacity
Tires (2).....	ST 175/80 D13 - 4 ply rating (1,360 lb. capacity each)
Dry Weight.....	Approximately 1,500 lbs.
Propane Bottle (1).....	100 lbs.
Generator.....	2,000 Watt - 12 Volt

SUPER SHOT 60 MELTER

INTRODUCTION

The CRAFCO SUPER SHOT 60 MELTER was developed to melt CRAFCO Brand Sealant. However, it will work well with most road asphalt and federal specification crack or joint sealant.

DO NOT operate machine without following these instructions:

1. Fill propane tank.
2. Check engine crankcase oil level (refer to Engine Operator's Manual).
3. Check hydraulic fluid level at ambient temperature. Add fluid if necessary to bring to correct level.
4. Check heat transfer oil level. At 70°F, the oil should be at the full mark on the dipstick. **DO NOT** overfill or spillage may occur when oil is heated and expands.
5. All toggle switches should be turned "**OFF**" and both temperature control dials at minimum settings.
6. Remember that safe operation of this equipment is the operator's responsibility.



CAUTION:

Extreme care must be used when operating this equipment. Safety is the result of being careful and paying attention to details. Remember the propane flame is about 2,200° F. Certain exposed parts of this machine, when operating reach 500° F.; the sealant as high as 400° F. and the hydraulic fluid may reach 200° F. Always wear protective clothing, hard-soled shoes, and eye protection. Be sure that all joints and fittings are tight and leak proof. Immediately replace any hose which shows any signs of wear, fraying, or splitting. Tighten all bolts, nuts, and screws every 250 hours.

MACHINE START UP

TO START BURNER

1. Open LPG tank valve.
2. Open line valve at cylinder.
3. Start engine.
- 3a. Choke engine then turn the ignition key to start position. Engine should start. After engine starts, allow it to warm up before using hydraulics or generator.
4. Turn “**POWER**” toggle switch at control box. Follow directions on control box.
5. Set hot oil temperature at 500° F. and material temperature at manufacturers recommended temperature.



CAUTION:

If burner does not ignite the first time, turn toggle switch to “OFF”. Turn toggle switch to “ON” again. Burner should ignite. If burner still does not ignite, determine cause of malfunction (see Trouble Shooting Guide).

NOTE: The solid material in the tank melts first around the walls and bottom of the material tank. Material temperature sensor is located by the wall; therefore, it is possible that at the beginning of the melting process the indicated temperature reaches operating value, but the material closer to the center of the tank is still solid. This is normal and when the heated hose is ready for operation, most of the material in the tank will be melted and heated to application temperature.

6. Allow the heating oil to continue to heat. When sealant material reaches 275° F. mixer may be engaged by turning the toggle switch at hydraulic control panel “**ON**”. If the mixer does not move, allow the material to heat longer. Jamming of mixer causes hydraulic oil to overheat and machine damage could occur. **NOTE: Mixer speed is preset at the factory and cannot be adjusted. Mixer cannot be engaged until material reaches 275° F.**
7. Hose will automatically turn “**ON**” when material temperature reaches approximately 275° F. See Operating Instructions. Adjust the temperature dial to 380° F. or manufacturers recommended temperature. The hose will come up to temperature in approximately 30 minutes. After the hose is hot, the light in the control box marked “heated hose” will turn off and the temperature may be reduced to approximately 360° F. It is advisable to run the hose at the recommended temperature setting.

NOTE!! The hose must be up to 325° F. before dispensing can take place. If hose does not dispense when trigger is activated then allow material to heat longer. If hose still does not dispense material then shut machine down and locate plug in the line and remove.

IMPORTANT!! DO NOT twist or kink hose. Avoid sharp bends and continuous twisting. Maintain minimum, 10 inch bend radius. **DO NOT** exceed 400° F. setting on hose controller!! **DO NOT** move or bend hose when cold. Damage may result. **DO NOT** leave hose “**ON**” for longer than 30 minutes without dispensing material. Coking will occur and permanently damage hose. **DO NOT** remove hose from boom during operation, kinking will occur.

MACHINE START UP

IT IS STRONGLY RECOMMENDED THAT THE HOSE BE STORED IN THE CORRECT LOCKED POSITION WHEN NOT IN USE OR WHEN IN TRANSIT.

8. The heated hose supplied with the machine is Teflon lined with steel over braid. It has a heating element, which runs down the hose to heat the material within the hose. The hose is covered with high temperature, durable rubber hose. The wand has an aluminum tube to protect both the wand and the operator. The pistol grip actuator is equipped with an electric switch which when depressed sends a signal to actuate the pump. At the end of the wand, a high temperature elastomeric output valve is attached. The valve is pressure actuated and opens automatically when fluid pressure is applied. The wand is equipped with a trigger lock to prevent accidental pump actuation when not pumping material. The trigger should be in the



DISPENSING THE MATERIAL



NOTE: PROTECTIVE CLOTHING, GLOVES, HARD SOLED SHOES, AND FACE SHIELD OR SAFETY GLASSES SHOULD BE WORN WHEN OPERATING OR FILLING THIS EQUIPMENT. READ ENTIRE MANUAL BEFORE OPERATING.

The wand is equipped with a disposable duckbill valve on the end which shuts off the flow of material when the pump is turned off and prevents excessive dripping of material. This valve also directs the material into a stream for easy application into the crack. Other sealing tips are available. See your local distributor for options.

Some difficulty may be encountered when starting up on cold days. Although the wand is designed to heat the material all the way down to the tip, on cold days it may be necessary to place the tip of the wand under the lid to facilitate material melting in the valve. Insert the wand tip for only a short time before proceeding.

When the material and the hose have reached proper application temperature, you are ready to dispense material. Turn the pump speed control to the lowest setting by turning the control knob to the minimum setting. With the wand tip inserted into the top of the melter, depress trigger on the wand and slowly increase pump speed by turning the speed control knob towards the maximum setting until the pump motor starts to turn. Material should start to flow from the tip of the duckbill valve. Adjust the pump speed for the desired rate of flow for the application and dispense material as required. The rate of flow may be varied while the pump is running by rotating the control knob.

If your machine has a shot timer option you will need to follow the following steps to dispense material. Locate the toggle switch in the main control box labeled “Pump”. this will allow you to switch from Crack Sealing Mode to Marker Mode.

Crack Sealing Mode

This is the standard mode of crack sealing and you would follow the step above starting at the top of this page to dispense material.

Marker Mode

This allows you to place a shot size between zero to 4 ounces each time you pull the trigger, there is a separate control box located near the main control box where the shot size can be controlled. Inside this control box you will position the knob to the desired shot size.



NEVER POINT THE WAND AT ANY PART OF THE BODY OR AT ANY OTHER PERSON. HOT MATERIALS CAN CAUSE SEVERE BURNS. WEAR PROTECTIVE EQUIPMENT WHEN FILLING OR OPERATING THE EQUIPMENT. READ MANUAL BEFORE OPERATING EQUIPMENT



ACTIVE PUMP PROTECTION

The pump is completely encircled by a protective screen. The screen shall not allow anything larger than 1/2” (1.27 cm) in size to pass from the sealant tank into the pump suction port. The screen shall continuously rotate 360 around the pump whenever the sealant agitator is engaged. The *active screen* will protect the pump from foreign object damage and will self clean as it rotates around the sealant pump and suction port.

LOADING THE MACHINE

When loading solid material into the sealant tank, the mixer will stop when the lid is lifted.

To load, lift the lid, place the material on the lid and close lid. Following this procedure will prevent the hot material from splashing and causing serious burns to personnel.

The solid material must be added at intervals, which will allow the mixer to rotate without jamming. If blocks of material are fed in too quickly, jamming will result and slow down the melting process.

SHUTDOWN AND CLEAN-OUT PROCEDURE

When shutting down the machine for the day, there are several schools of thought about how much material to leave in the machine. Crafcro recommends leaving the melter about half full. This will give a fairly rapid heat up rate in the morning, but will allow enough material to start dispensing right away when the material becomes molten.

1. Leaving the hose in the boom, swing the boom clockwise towards the front of the machine and lock the boom into position with the latch provided.
2. Place the wand in the wand holder and lock the wand into position with the latch provided.
3. Reverse the pump for approximately 30 seconds.
4. Turn the "POWER" toggle switch "OFF".
5. Turn the mixer toggle switch to "OFF".
6. Shut the engine down by turning the key to the "OFF" position.
7. Turn LPG off at the line valve and the valve at LPG bottle.

STORING MACHINE

The melter should be stored in an area where moisture cannot enter machine heating system, such as hot oil, controls, etc. Extended down time can cause moisture build up in heating oil tank.

If there is any suspicion that moisture may have collected in heat transfer oil, warm heat transfer fluid to 300° F. for 2 to 3 hours to evaporate the moisture.

INSTRUCTIONS FOR ORDERING PARTS

Parts may be ordered from your local CRAFCO distributor or directly from CRAFCO, Inc. if a distributor is not available in your area. When ordering parts, give the following information:

1. Part number.
2. Machine model.
3. Serial number.

Write, telephone, or fax:

CRAFCO, INCORPORATED
420 N. Roosevelt Ave.
Chandler, AZ 85226-2601
Phone: 602-276-0406
Fax: 480-961-0513
Toll Free: 1-800-528-8242

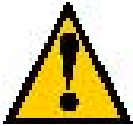

ELECTRIC HOSE CARE AND CAUTIONS

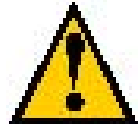

Twisting and kinking of the electric hose (used on LF, BAX, SS60, and SS125 Melter) is the number one cause of hose failure. When this happens, the electric heating wires are shorted out to the metal hose cover and the hose stops heating. **This type of failure is not covered under the Crafcoc warranty.**

To help prevent twisting and kinking and the resulting hose damage, the operator should:

- a. Not move or use hose unless it has been turned on at least 35 minutes and set at a minimum temperature of 300°F.
- b. Make sure hose swivel between hose and wand moves freely.
- c. Limit the hose bending to a radius of 10 inches.
- d. Avoid bending the hose over sharp edges such as the edge of the frame or tank.
- e. Avoid twisting.
- f. Do not exceed 400°F. on the hose controller or material temperature.
- g. Follow all instructions of the melter as well as those in the instruction manual.
- h. Avoid pulling hose beyond its limits.

HOSE TRANSPORT INSTRUCTIONS

1. Leaving the hose in the boom, swing the boom clockwise towards the front of the machine and lock the boom into position with the latch provided.
2. Place the wand in the wand holder and lock the wand into position with the latch provided.

CAUTION:



Hose damage will occur if:

- a. Hose is bent or moved when cold.
- b. Hose is twisted or bent at less than a 10 inch radius.
- c. Hose is moved prior to being turned on at least 35 minutes and set at 380° F.
- d. Operator crosses over or under hose causing hose to twist or wires between hose and wand connection to twist or wrap up.
- e. Swivel is cold and not free to move allowing hose to twist.
- f. Hose to wand wiring is pulled, stressed, or used to support the wand.

MAINTENANCE INSTRUCTIONS

ENGINE

See Engine Owner Manual for operating and maintenance instructions.

HYDRAULIC SYSTEM

Check hydraulic fluid daily. Change hydraulic filter every 250 hours of operation. Change hydraulic fluid every 500 hours of operation.

HEAT TRANSFER OIL

Check oil level every 8 hours of operation. Change oil every 500 hours of operation.

WHEEL BEARINGS

Re-pack wheel bearings every 24,000 miles or every two years, using a good grade of bearing grease.

LUG NUTS

Wheel nuts/bolts should be torqued before first road use and after each wheel removal. Check and retorque after the first 10 miles, 25 miles, and again at 50 miles. Check periodically thereafter. Torque in stages. 1st stage 20-25 ft.lbs., 2nd stage 35-40 ft.lbs., 3rd stage 50-75 ft.lbs.

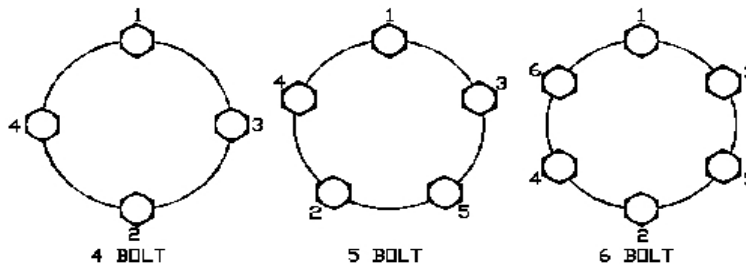

TIGHTENING SEQUENCE

BRAKES

Check brakes daily. Refer to DEXTER AXLE Operation Maintenance Service Manual located in the manual box.

TONGUE JACK

Lubricate tongue jack, using a good grade of bearing grease.

MIXER BEARING

Lubricate every 50 hours with good quality, high temperature grease.

TEMPERATURE CONTROL CALIBRATION

Check control knob calibration weekly.

1. Calibrate by aligning the line on the control knob with the calibration line on the scale plate (See Fig. 1).

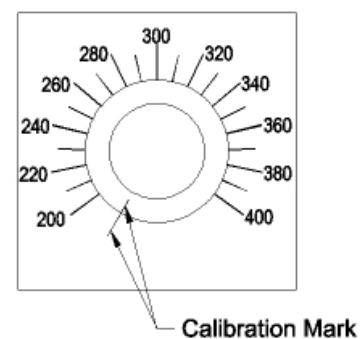

Fig. 1

MAINTENANCE CHART

		HOURS			
LOCATION	PROCEDURE	8	50	250	500
Engine check oil level	See Engine Instruction Manual.	*			
Other engine maintenance	See Engine Operating and Maintenance Instructions.				
Battery	Check water level weekly.		*		
Heat Transfer Oil	Check	*			
Heat Transfer Oil	Change				*
Hydraulic oil filter	Change every 250 hours.			*	
Hydraulic oil	Check oil.	*			
Hydraulic oil	Change oil.				*
Hydraulic oil	For proper oil, see Recommended Fluids & Lubricants.				

SERVICE INSTRUCTIONS

1. Conduct a general inspection of your machine at least once a week. Replace all worn or damaged parts, make any necessary adjustments, and tighten all loose nuts or screws.
2. Keep regular replacement items in stock for emergency repairs to avoid costly "down" time.
3. Watch for leaks. Tighten fitting or repair as necessary.
4. Clean machine externally periodically. Check with sealant manufacturer for recommendation.
5. Follow recommended maintenance procedures on maintenance chart.

RECOMMENDED FLUIDS AND LUBRICANTS

APPLICATION	RECOMMENDED	FULL POINT
Engine oil	Refer to Kohler Owners Manual.	4 Pts.
LPG	Propane	100 Lbs.
Hydraulic oil	Rondo Oil - HD - 68 Texaco	24 Gals.
Heating oil	Regal R&O 68	23 Gals.

The following is a list of suitable heat transfer oil to be used in CrafcO equipment.

PRODUCER	PRODUCT NAME	PRODUCT NUMBER
Texaco	Regal	R&O 68
Exxon	Caloria	HT 43
Arco	Rubilene	--
Citgo	Sentry	R&O 68
Gulf Oil Co.	Security	R&O 68
Shell Oil Co.	Therma	C
Chevron	Chevron Heat Transfer Oil	--
Conoco	Heat Transfer Oil	R&O 68

TYPICAL SPECIFICATIONS

ISO	68	Viscosity Index	95-100
Flash Point, COC	445° F	Pour Point	0° F
Viscosity @ 100° F.-SUS	325	Carbon Residue	1%
Viscosity @ 210° F.-SUS	50		



WARNING:

The heat transfer oil in this machine is a grade that has been tested and recommended by CrafcO, Inc. The addition of any grade of oil not specifically recommended by CrafcO, Inc., shall be cause for warranties to be voided. All oils subjected to high temperatures deteriorate with time and lose many of their characteristics. Tests conducted by CrafcO, Inc. have determined that for best results and safety, the heat transfer oil in this machine must be drained and replaced with CrafcO, Inc. recommended oil after five hundred (500) hours of operation or one (1) year, whichever occurs first.

SUPER SHOT PUMP REPLACEMENT

Step 1

Bring melter up to temperature as preparation for draining the material tank. Remove pipe cap located at rear of machine and drain tank (**CAUTION!! EXTREMELY HOT MATERIAL**).



Step 2

Remove both guards from the motor mount to access the chain and sprockets.

Step 3

Rotate agitator until connecting link is accessible. Disassemble the connecting link and remove the drive chain.

Step 4

Loosen set screw in the lower coupling half between the hydraulic motor and the drive shaft.

Step 5

Remove the (4) hydraulic hoses and cap off all ports. Note: Mark hoses for ease of replacement.

Step 6

Remove the (4) bolts holding motor mount on top of melter. Lift off motor mounting and set aside.

Step 7

Remove (2) bolts holding agitator shaft bearing. Note: Do not remove bearing from agitator shaft.

Step 8

When unit has cooled sufficiently, remove (6) bolts holding paddles on top of screen. Remove paddles from tank.

Step 9

Remove pump drive shaft from center of agitator shaft then lift agitator shaft and screen assembly as high as possible and insert screw driver into shaft hole. This will support the assembly while removing the pump from the tank.

Step 10

Remove the (6) bolts, which fasten the pump to the tank. Lift the pump from the material tank (**CAUTION!! THE PUMP WEIGHS APPROXIMATELY 90LBS.**)

Step 10

IMPORTANT: Clean any sealant from top of pump mounting plate and clean-out shaft holes. (**WARNING!!! PREMATURE PUMP WEAR WILL OCCUR IF THIS IS NOT DONE.**)

SUPER SHOT PUMP REPLACEMENT

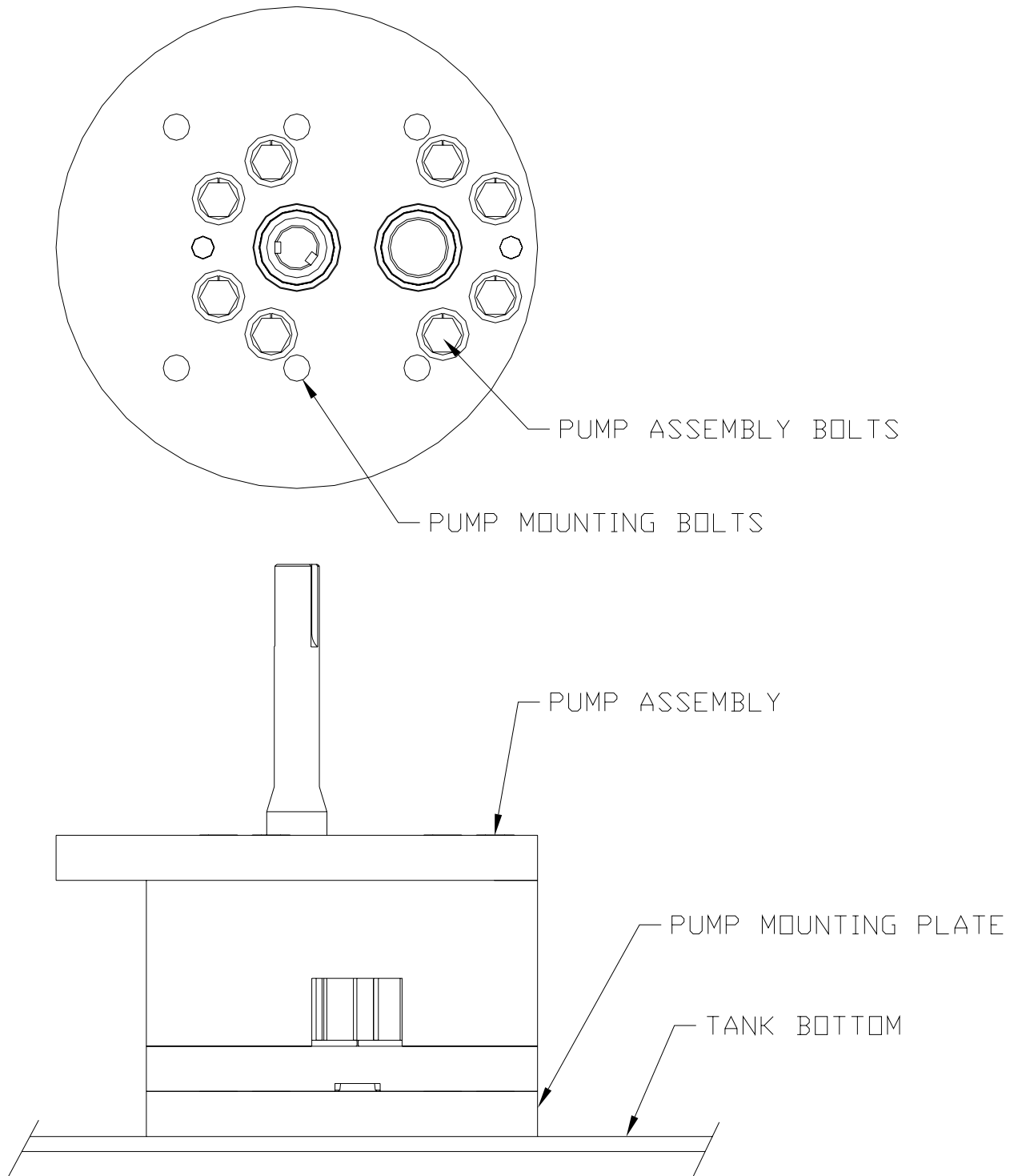

TROUBLE SHOOTING GUIDE

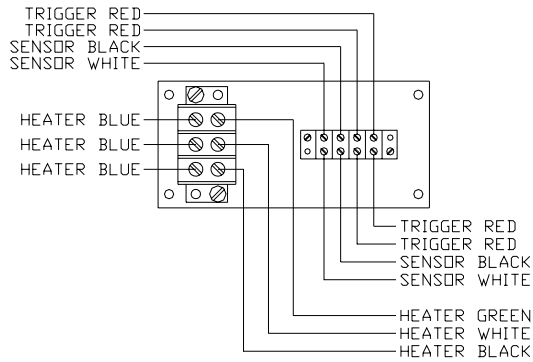

KETTLE END

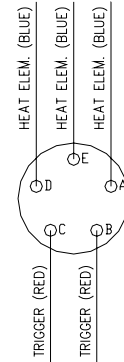

WAND END

HOSE DOES NOT HEAT

Step 1: Is the “MATERIAL” temperature at 275°F?

YES: Go to step 2.

NO: Turn “POWER” toggle switch “ON”.

Step 2: Is “HEATED HOSE” light illuminated?

YES: Go to step 3.

NO: Check for tripped circuit breaker in front panel.

YES: Reset circuit breaker.

NO: Remove front panel and check for 12 volts at pink wire terminal #2 of the material Pak-Stat.

YES: Go to step 2a.

NO: Check for 12 volts at pink wire terminal #9 of the hose Pak-Stat.

Step 2a: Check for 12 volts at #3 terminal (pink wire) on the hose Pak-Stat.

YES: Go to step 2b.

NO: Check wire connections or go to step 1.

Step 2b: Check for 12 volts at #4 terminal (blue wire) when Pak-Stat is on.

YES: Go to step 3.

NO: Check the ohms between black and white wires at terminals #6 and #7.

(NOTE: One of the sensor wires must be disconnected to check resistance) See page 27 for the corresponding temperature reading.

Temperature reading should match LCD readout.

YES: Replace Pak-Stat.

NO: Replace hose.

Step 3: Check for 12 volts at “BATT” terminal on generator.

YES: Go to step 4.

NO: Check 12 volts at terminal strip (blue wire) in control box.

Step 4: Check for 24 volts AC at the “BLACK”, “WHITE” and “GREEN” wires on the generator. (Check between blk and wht, blk and grn, wht and grn)

YES: Go to step 5.

NO: Replace generator.

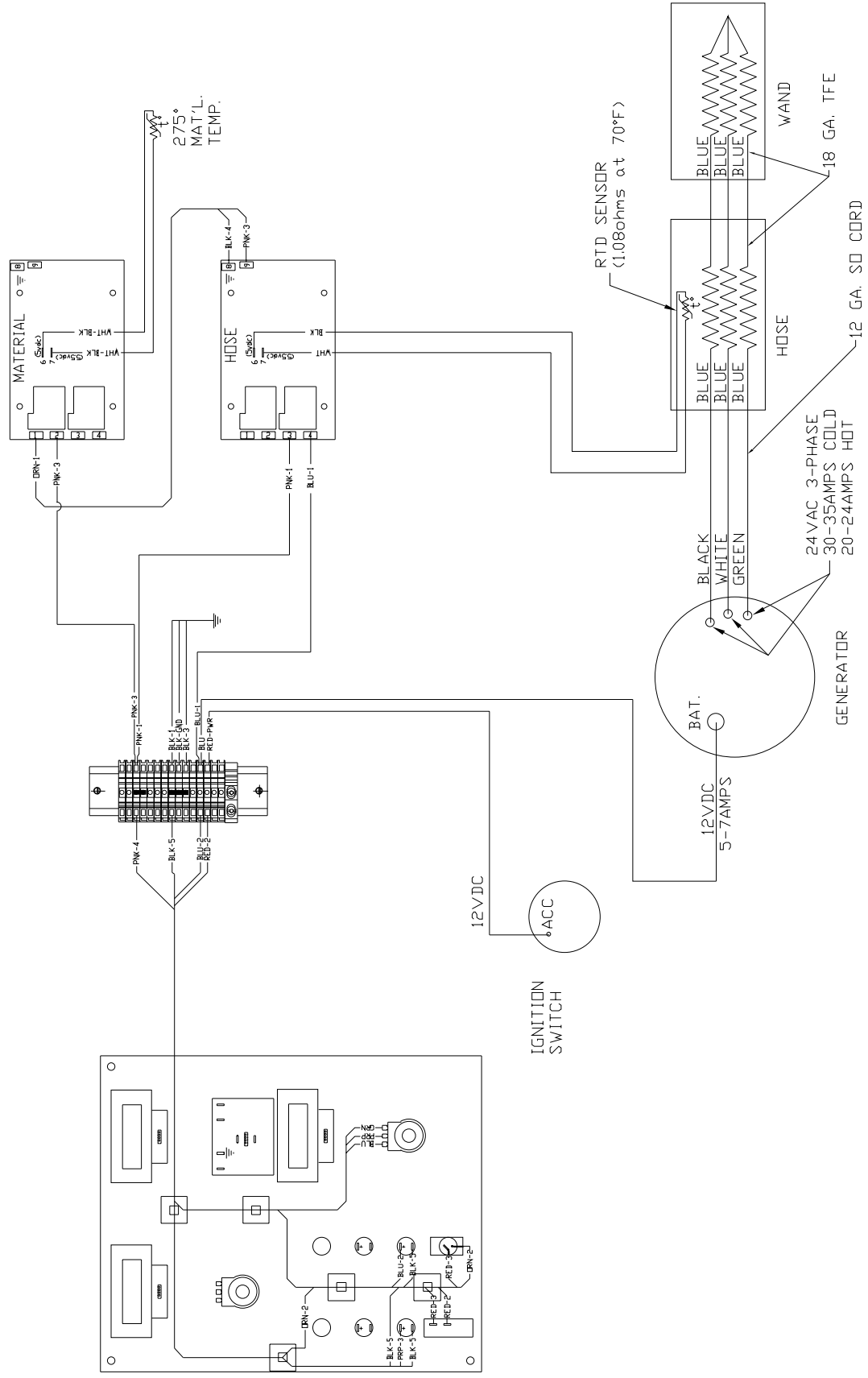

HOSE CIRCUIT

TROUBLE SHOOTING GUIDE

Step 5: Check for 30 amps (cold) or 22-24 amps (hot) at the 3 blue wires in the junction box. **(Always use a clamp-on AMP meter to perform this test)**

YES: Hose should be operating properly.

NO: Go to step 6.

Step 6: Check for continuity between three heating element wires (blue) in junction box. **(NOTE: Wires must be disconnected from terminal block)**

YES: Go to step 7.

NO: Check continuity between terminals “A”, “E”, and “D” at the wand.

YES: Wand is Ok. Go to step 7.

NO: Replace wand.

Step 7: Check for continuity between element wires (blue) and the fitting of the hose.

YES: Replace hose.

NO: Hose is OK.

MATERIAL DOES NOT DISPENSE WHEN PUMP IS ACTIVATED

Step 1: Is the motor coupling turning?

YES: Go to step 2.

NO: Has the sealant had sufficient time to completely melt?

YES: Go to step 2.

NO: Has the hose had sufficient time to reach operating temperature?

YES: Go to step 2.

NO: Allow hose to heat up to operating temperature.

Step 2: Is the “MATERIAL” temperature at 275°F ?

YES: Go to step 3.

NO: Allow material to heat longer or turn “POWER” toggle switch “ON”.

Step 3: Is the “PUMP” light illuminated?

YES: Go to step 4.

NO: Hose temperature must be at 325°F before the pump will activate.

Step 4: Check for 12 volts at terminals #12 (red-blk wire) and terminal #14 (green wire) of the relay. **(NOTE: Terminal #12 will have 12 volts when the key is “ON”. Terminal #14 will have 12 volts when trigger is activated.)**

YES: Go to step 4a.

NO: Check continuity of red trigger wires in junction box.

Yes: Go to step 5.

No: Check for continuity between terminals “C” and “B” on wand when the trigger is activated.

YES: Go to step 5.

NO: Replace trigger or check for poor connections.

Step 4a: Check relay by pressing the white test button on top of relay. **(CAUTION: Pump will dispense material).**

YES: Go to step 5.

NO: Replace relay.

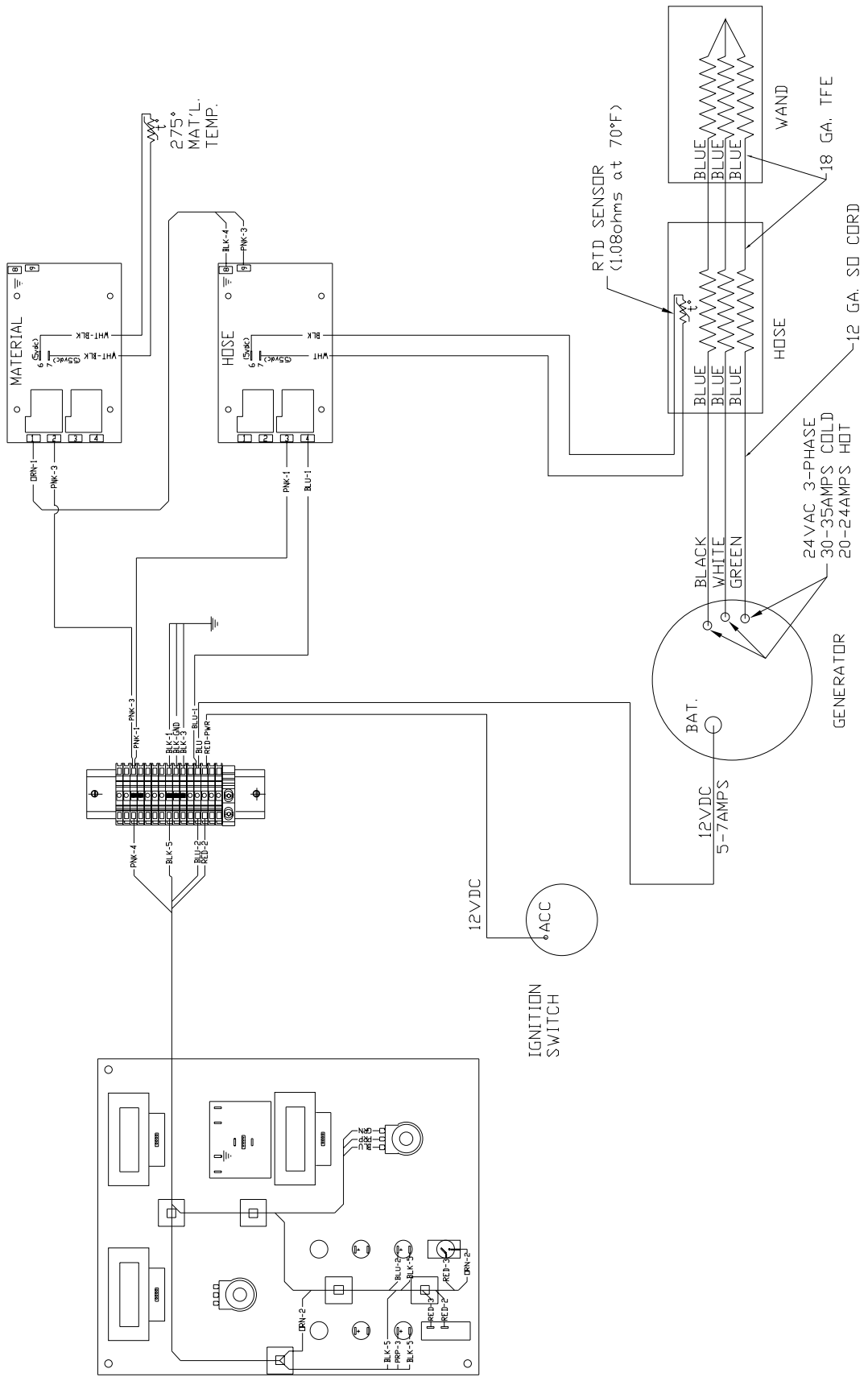

HOSE CIRCUIT

TROUBLE SHOOTING GUIDE

Step 5: Is the top right light on hydraulic valve illuminated (looking at the rear of the hydraulic valve) when trigger is activated?

YES: Replace hydraulic cartridge.

NO: Go to step 4.

PUMP ROTATES BUT NO MATERIAL IS DISCHARGED

Step 1: Has the sealant and heated hose had sufficient time to reach temperature?

YES: Go to step 2.

NO: Allow the sealant and hose to heat longer.

Step 2: Check material outlet pipe and connection between hose and wand for obstruction.

YES: Remove obstruction and reassemble hose connection.

NO: Go to step 3.

Step 3: Is there an obstruction at the pump suction?

YES: Reverse material pump for 30 seconds.

NO: Refer to page 20 for pump removal if required.

MATERIAL DISPENSING RATE IS TOO SLOW

Step 1: Check speed control knob for desired flow adjustment.

YES: Go to step 2.

NO: Adjust to desired flow.

Step 2: Is there enough material in the tank?

YES: Go to step 3.

NO: Add enough material to bring tank level above the screen.

Step 3: Check material outlet pipe and connection between hose and wand for obstruction.

YES: Remove obstruction and reassemble hose connection.

NO: Pump is worn out (See page 20 for pump removal and installation).

RTD SENSOR - OHMS vs. TEMPERATURE

The following chart shows what the ohm reading would be for a given temperature. This is to be used when trouble shooting the burner and the hose. The following are the instructions for use.

1. Measure the resistance(Ohms) of the sensor in question with an Ohm meter.
2. Find the reading in the chart.
3. Follow the row to the left and get the temperature in 10° increment, then follow the column up to get the 1° increment. **Example:** 1573 Ohms =302°

°F	0	1	2	3	4	5	6	7	8	9
0	930.3	932.5	934.7	936.9	939.1	941.3	943.4	945.6	947.8	950.0
10	952.2	954.3	956.5	958.7	960.9	963.0	965.2	967.4	969.6	971.8
20	973.9	976.1	978.3	980.5	982.6	984.8	987.0	989.1	991.3	993.5
30	995.7	997.8	1000.0	1002.2	1004.3	1006.5	1008.7	1010.9	1013.0	1015.2
40	1017.4	1019.5	1021.7	1023.9	1026.0	1028.2	1030.4	1032.5	1034.7	1036.9
50	1039.0	1041.2	1043.4	1045.5	1047.7	1049.8	1052.0	1054.2	1056.3	1058.5
60	1060.7	1062.8	1065.0	1067.1	1069.3	1071.5	1073.6	1075.8	1077.9	1080.1
70	1082.2	1084.4	1086.6	1088.7	1090.9	1093.0	1095.2	1097.3	1099.5	1101.6
80	1103.8	1106.0	1108.1	1110.3	1112.4	1114.6	1116.7	1118.9	1121.0	1123.2
90	1125.3	1127.5	1129.6	1131.8	1133.9	1136.1	1138.2	1140.4	1142.5	1144.7
100	1146.8	1149.0	1151.1	1153.2	1155.4	1157.5	1159.7	1161.8	1164.0	1166.1
110	1168.3	1170.4	1172.5	1174.7	1176.9	1179.0	1181.1	1183.3	1185.4	1187.5
120	1189.7	1191.8	1194.0	1196.1	1198.2	1200.4	1202.5	1204.6	1206.8	1208.9
130	1211.0	1213.2	1215.3	1217.5	1219.6	1221.7	1223.9	1226.0	1228.1	1230.3
140	1232.4	1234.5	1236.7	1238.9	1240.9	1243.0	1245.2	1247.3	1249.4	1251.6
150	1253.7	1255.8	1258.0	1260.1	1262.2	1264.3	1266.5	1268.6	1270.7	1272.8
160	1275.0	1277.1	1279.2	1281.3	1283.5	1285.6	1287.7	1289.8	1292.0	1294.1
170	1296.2	1298.3	1300.4	1302.6	1304.7	1306.8	1308.9	1311.0	1313.2	1315.3
180	1317.4	1319.5	1321.6	1323.8	1325.9	1328.0	1330.1	1332.2	1334.3	1336.5
190	1338.6	1340.7	1342.8	1344.9	1347.0	1349.1	1351.2	1353.3	1355.4	1357.6
200	1359.7	1361.8	1363.9	1366.0	1368.1	1370.2	1372.3	1374.4	1376.5	1378.7
210	1380.8	1382.9	1385.0	1387.1	1389.2	1391.3	1393.4	1395.5	1397.6	1399.7
220	1401.8	1403.9	1406.0	1408.1	1410.3	1412.4	1414.5	1416.6	1418.7	1420.8
230	1422.9	1425.0	1427.1	1429.2	1431.3	1433.4	1435.5	1437.6	1439.6	1441.7
240	1443.8	1445.9	1448.0	1450.1	1452.2	1454.3	1456.4	1458.5	1460.6	1462.7
250	1464.8	1466.9	1469.0	1471.1	1473.2	1475.3	1477.3	1479.4	1481.5	1483.6
260	1485.7	1487.8	1489.9	1492.0	1494.1	1496.1	1498.2	1500.3	1502.4	1504.5
270	1506.6	1508.7	1510.8	1512.8	1514.9	1517.0	1519.1	1521.2	1523.3	1525.3
280	1527.4	1529.5	1531.6	1533.7	1535.7	1537.8	1539.9	1542.0	1544.1	1546.1
290	1548.2	1550.3	1552.4	1554.5	1556.5	1558.6	1560.7	1562.8	1564.8	1566.9
300	1569.0	1571.1	1573.1	1575.2	1577.3	1579.4	1581.4	1583.5	1585.6	1587.7
310	1589.7	1591.8	1593.9	1595.9	1598.0	1600.1	1602.2	1604.2	1606.3	1608.4
320	1610.4	1612.5	1614.6	1616.6	1618.7	1620.8	1622.8	1624.9	1627.0	1629.0
330	1631.1	1633.2	1635.2	1637.3	1639.3	1641.4	1643.5	1645.5	1647.6	1649.7
340	1651.7	1653.8	1655.8	1657.9	1660.0	1662.0	1664.1	1666.1	1668.2	1670.2
350	1672.3	1674.4	1676.4	1678.5	1680.5	1682.6	1684.6	1686.7	1688.7	1690.8
360	1692.9	1694.9	1697.0	1699.0	1701.1	1703.1	1705.2	1707.2	1709.3	1711.3
370	1713.4	1715.4	1717.5	1719.5	1721.6	1723.6	1725.7	1727.7	1729.8	1731.8
380	1733.9	1735.9	1737.9	1740.0	1742.0	1744.1	1746.1	1748.2	1750.2	1752.3
390	1754.3	1756.3	1758.4	1760.4	1762.5	1764.5	1766.6	1768.6	1770.6	1772.7
400	1774.7	1776.8	1778.8	1780.8	1782.9	1784.9	1786.9	1789.0	1791.0	1793.1
410	1795.1	1797.1	1799.2	1801.2	1803.2	1805.3	1807.3	1809.3	1811.4	1813.4
420	1815.4	1817.5	1819.5	1821.5	1823.6	1825.6	1827.6	1829.6	1831.7	1833.7
430	1835.7	1837.8	1839.8	1841.8	1843.8	1845.9	1847.9	1849.9	1851.9	1854.0
440	1856.0	1858.0	1860.0	1862.1	1864.1	1866.1	1868.1	1870.2	1872.2	1874.2
450	1876.2	1878.2	1880.3	1882.3	1884.3	1886.3	1888.3	1890.4	1892.4	1894.4
460	1896.4	1898.4	1900.5	1902.5	1904.5	1906.5	1908.5	1910.5	1912.6	1914.6
470	1916.6	1918.6	1920.6	1922.6	1924.6	1926.6	1928.7	1930.7	1932.7	1934.7
480	1936.7	1938.7	1940.7	1942.7	1944.7	1946.8	1948.8	1950.8	1952.8	1954.8
490	1956.8	1958.8	1960.8	1962.8	1964.8	1966.8	1968.8	1970.8	1972.8	1974.8
500	1976.8	1978.8	1980.8	1982.9	1984.9	1986.9	1988.9	1990.9	1992.9	1994.9
510	1996.9	1998.9	2000.9	2002.9	2004.9	2006.9	2008.8	2010.8	2012.8	2014.8
520	2016.8	2018.8	2020.8	2022.8	2024.8	2026.8	2028.8	2030.8	2032.8	2034.8
530	2036.8	2038.8	2040.8	2042.8	2044.7	2046.7	2048.7	2050.7	2052.7	2054.7
540	2056.7	2058.7	2060.7	2062.7	2064.6	2066.6	2068.6	2070.6	2072.6	2074.6
550	2076.6	2078.5	2080.5	2082.5	2084.5	2086.5	2088.5	2090.4	2092.4	2094.4

BURNER SCHEMATIC

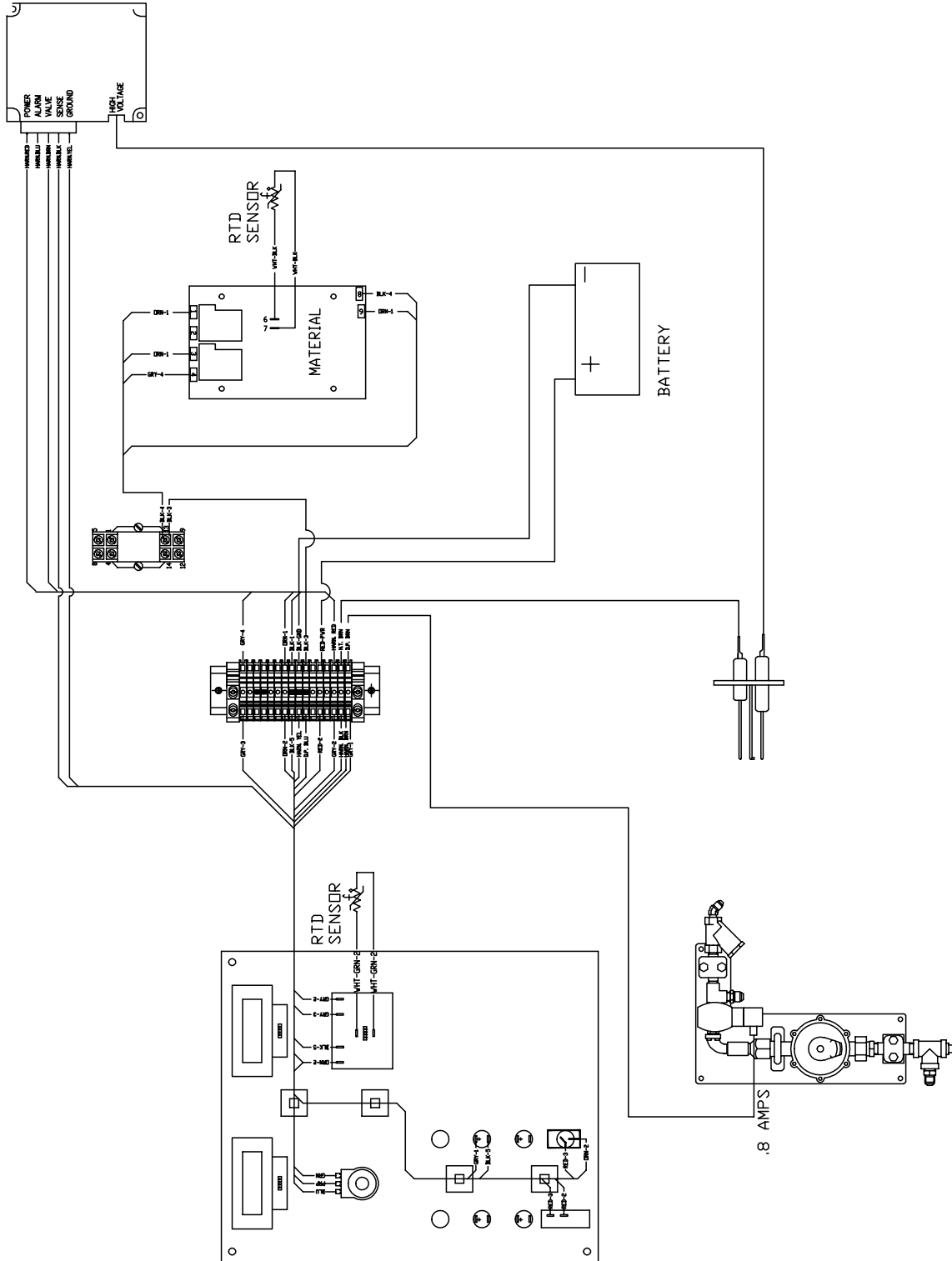

SS60 LPG BURNER SCHEMATIC

BURNER TROUBLE SHOOTING

BURNER WILL NOT IGNITE

Step 1: Check for 12 volts at toggle switch.

No: Then toggle switch is "OFF"
Fuse is "Blown"
Broken wire

Yes: Then go to Step 2



Step 2: Check for 12 volts at terminal #4 on material Pak-Stat.

No: BadPak-Stat
Faulty Sensor

Yes: Then go to Step 3

Step 3: Check for 12 volts at terminal #7 on hot oil Pak-Stat.

No: Then oil temperature thermostat is bad

Yes: Then go to Step 4

Step 4: Check for 12 volts at power terminal of spark control module.

No: Then there is a bad connection or a broken wire

Yes: Then there is a Faulty spark control module
Faulty ignitor or ignitor wire
Reposition ignitor
Check for clogged burner orifice
Inadequate gas flow/or pressure
Faulty "ASCO" gas valve

BURNER LIGHTS BUT SHUTS DOWN IN 7.0 SECONDS

Faulty ignitor
Broken or loose flame sensor wire
Faulty spark control module

BURNER LIGHTS BUT WILL NOT RELIGHT

Calibrate thermostat
Blown fuse
Faulty spark control module
Faulty sensor

BURNER WILL NOT SHUT OFF @ TEMPERATURE SETTING

Calibrate thermostat
Dirt in "ASCO" valve
Faulty sensors

TROUBLE SHOOTING HYDRAULICS

PROBLEM	CAUSE	REMEDY
Mixer will not rotate.	Sealant temperature too low.	Continue to heat material.
Mixer will not rotate.	Too many blocks placed at one time.	Continue to heat material.
Mixer will not rotate.	Inadequate hydraulic flow/pressure.	Check hydraulic fluid level.
Mixer will not rotate.	Toggle switch turned off.	Reset pressure, check flow if necessary.
Material pump will not rotate.	Material in tank not to operating temperature.	Continue heating material.
Material pump will not rotate.	Inadequate hydraulic flow/pressure.	Check hydraulic fluid level. Reset pressure, check flow as necessary.
Material pump will not rotate.	Material pump damaged.	Remove and replace.
Material pump will not rotate.	Foreign object lodged in pump.	Remove pump, clean & replace.
Material pump will not rotate.	Temperature at wand tip is inadequate.	Set wand tip inside material tank.
Material pump will not rotate.	Bad switch at wand.	Remove and replace.
Material pump will not rotate.	Hydraulic cartridge failure.	Remove and replace.
Material pump will not rotate.	Hydraulic coil failure.	Remove and replace.
When applying sealant it stops flowing from applicator wand.	Tank fluid level too low for material to flow into pump.	Add more material or continue heating material until more liquid material is available.
Pump rotates, but will not pump material.	Material cold, inlet still solid. Hose not to temperature. Temperature at wand tip is inadequate.	Continue to heat material. Allow to heat longer. Set wand tip inside material tank.
Pump does not rotate.	Bad wire connection. Bad switch at wand handle. Hydraulic cartridge failure. Hydraulic coil failure.	Find bad repair. Remove and replace. Remove and replace. Remove and replace.
Slow heat up of sealant.	Built up of coked material on inside of material tank. Low heating oil level. Low heating oil temperature.	Allow machine to cool. Remove deposits and flush with solvent. Make sure fluid level is correct. Set at recommended temperature.

HYDRAULICS SCHEMATIC

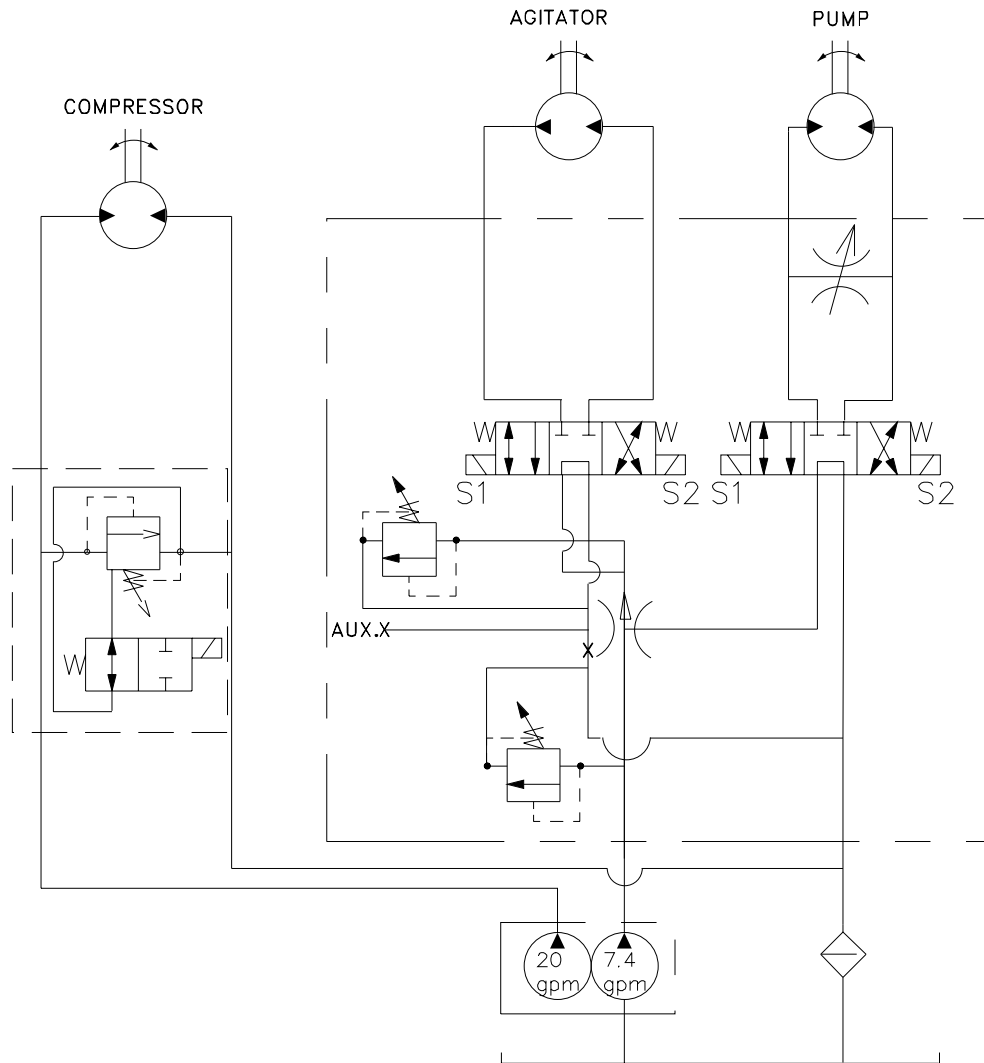

Flow = 7.0 GPM @ 2850 RPM
 Relief Valve Mixer (RVA) = 1000 PSI
 Relief Valve Pump (RVP) = 1000 PSI

SS60 MELTER ASSEMBLY

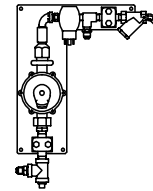
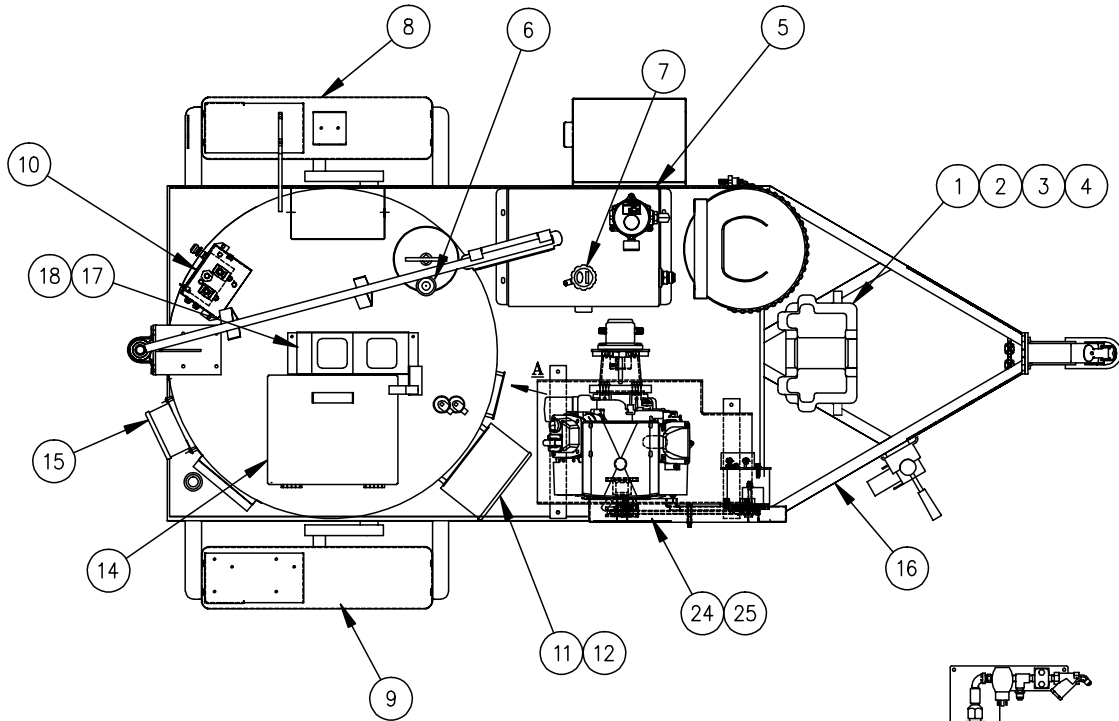

VIEW A

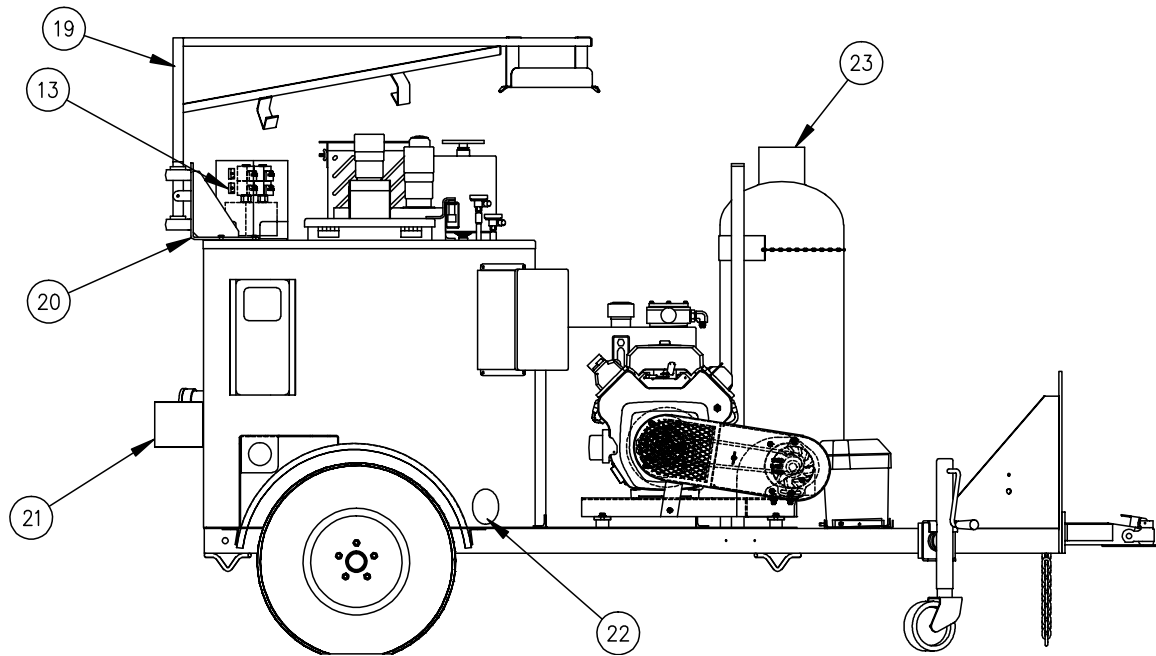

SS60 MELTER ASSEMBLY

NUMBER	PART NUMBER	QTY.	DESCRIPTION
1	24002	1	BATTERY BOX
2	24000	1	12 VOLT BATTERY
3	37038	1	BATTERY CABLE (-)
4	32602	1	BATTERY CABLE (-)
5	43595	1	HYDRAULIC TANK ASSEMBLY
6	26025	1	AIR BREATHER
7	43579	1	FILLER/BREATHER
8	44776	1	DRIVER SIDE FENDER ASSEMBLY
9	44777	1	CRUB SIDE FENDER ASSEMBLY
10	44819	1	MOUNTING BRACKET - HYDRAULIC VALVE
11	44075	1	CONTROL BOX ASSEMBLY
12	50074	4	MOUNTING SPACER
13	51678	1	SWITCH - AGITATOR
14	43338	1	LID ASSEMBLY
15	44027	1	JUNCTION BOX
16	43301	1	FRAME ASSEMBLY
17	44832	1	PUMP/AGITATOR MOTOR ASSEMBLY
18	43727	2	CHAIN GUARD
19	45560	1	HOSE BOOM ASSEMBLY
20	45549	1	BOOM SUPPORT ASSEMBLY
21	43821	1	HEAT GUARD
22	43154	1	BURNER DOOR
23	25118	1	LPG BOTTLE
24	44310	1	POWER PACK COMPLETE
25	44385	4	ISOMOUNT

SS60 MELTER ASSEMBLY

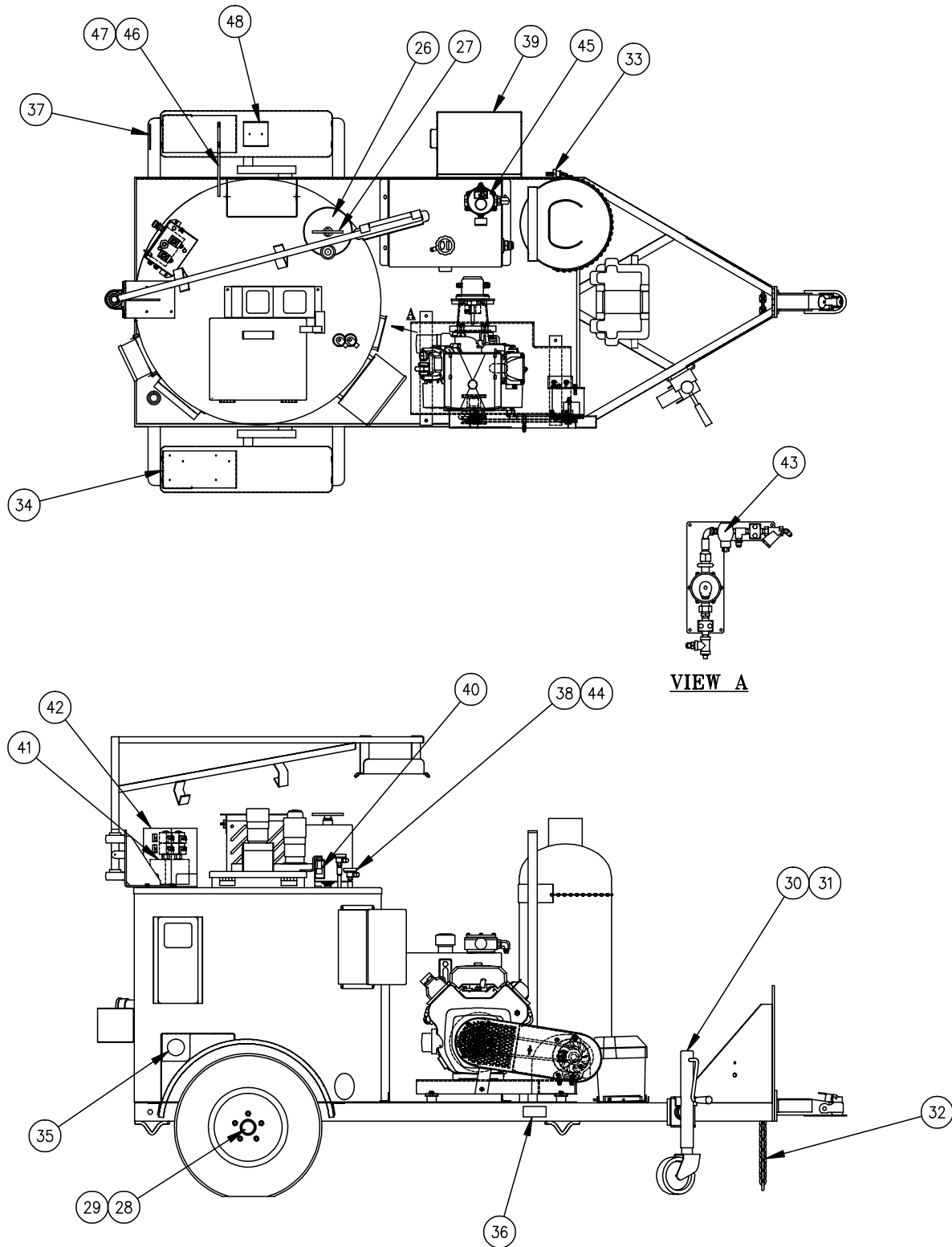

SS60 MELTER ASSEMBLY

NUMBER	PART NUMBER	QTY.	DESCRIPTION
26	43355	1	OVERFLOW TANK
27	43374	1	DIPSTICK - OVERFLOW TANK
28	43577	1	2000# TORSIONAL AXLE ASSEMBLY
29	44340	2	TIRE ASSEMBLY WITH RIM
30	40105	1	SWIVEL JACK
31	40106	1	JACK BRACKET
32	40121	2	SAFETY CHAIN
33	26032	1	BLACK KNOB
34	40048R	2	4" RED STOP, TURN AND TAIL
35	10208R	2	2 1/2" RED SIDE REFLECTOR
36	24290	2	YELLOW SIDE MARKER
37	90544	1	LICENSE PLATE BRACKET W/ LIGHT
38	43465	2	RTD SENSOR
39	43624	1	DRIP PAN
40	39608	1	SWITCH - LID
41	45420	1	HYDRAULIC VALVE ASSEMBLY
42	44821	1	COVER, HYDRAULIC VALVE
43	45592	1	GAS MANIFOLD ASSEMBLY
44	51065	2	CORD GRIP
45	45430	1	HYDRAULIC OIL FILTER ASSEMBLY
45a	45438	-	FILTER ELEMENT
45b	45440	-	O-RING - HYDRAULIC FILTER
45c	45441	-	GASKET - HYDRAULIC FILTER
46	45558	1	WAND SUPPORT
47	45559	1	LOCKING ARM WAND SUPPORT
48	45562	1	HOSE GUIDE
49	51730	1	WAND ASSEMBLY 48" (NOT SHOWN)
50	51731	1	ELECTRIC HOSE ASSEMBLY 15' (NOT SHOWN)

TANK DETAIL

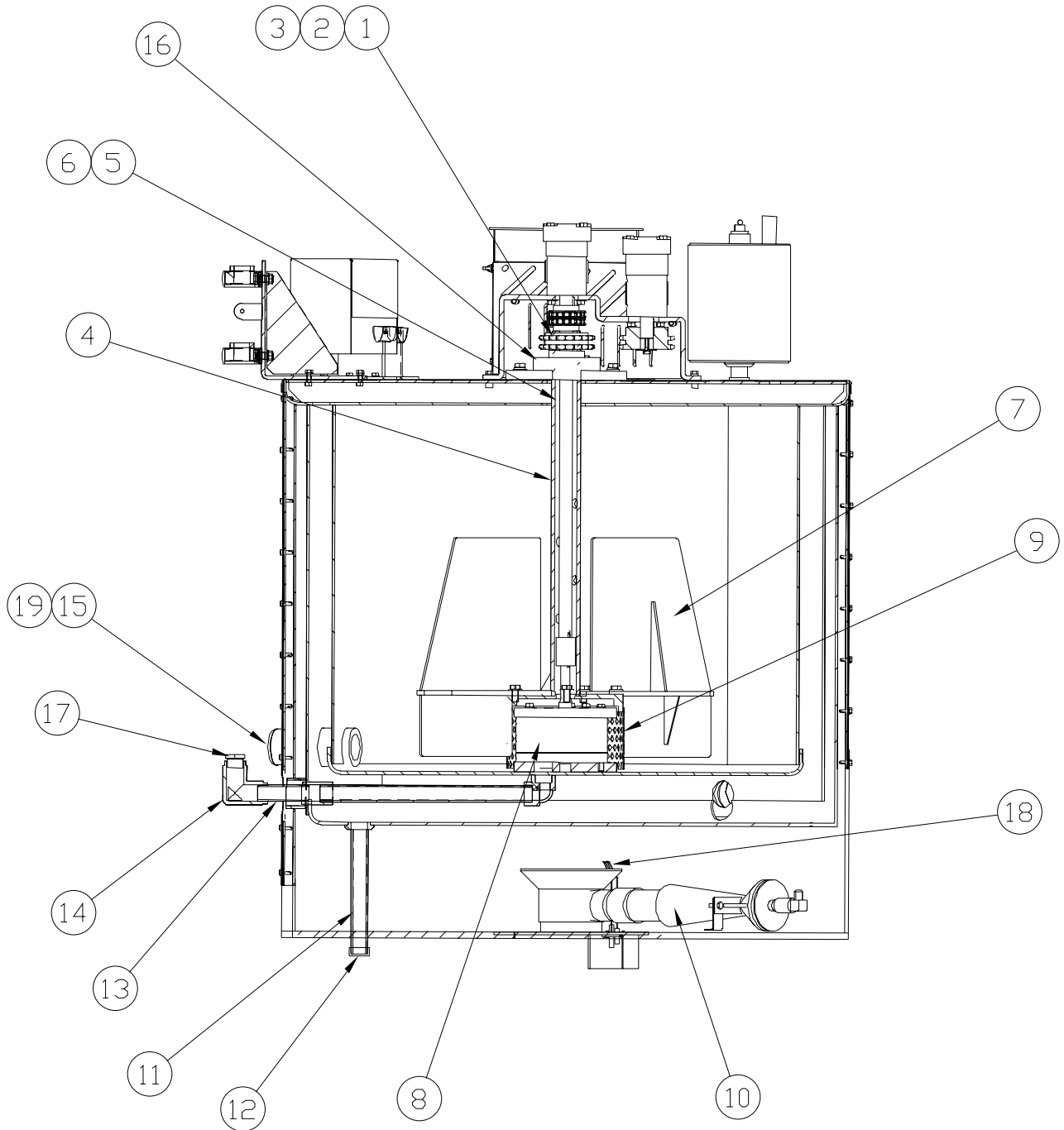

TANK DETAIL

NUMBER	PART NUMBER	QTY.	DESCRIPTION
1	44165	1	SPROCKET - DRIVEN
2	43321	1	CHAIN - DRIVE
3	26030	1	CONNECTING LINK - CHAIN
4	43545	1	AGITATOR SHAFT
4a	44163	1	KEY, AGITATOR SHAFT
5	43548	1	DRIVE SHAFT - PUMP
6	40084	1	KEY, 3/16 SQ. X 7/8 LG.
7	43325	2	PADDLE ASSEMBLY
8	44850	1	PUMP ASSEMBLY
9	43655	1	STRAINER ASSEMBLY
10	43123	1	BURNER ASSEMBLY
11	28174	1	1" X 15" PIPE NIPPLE
12	28270	1	1" PIPE CAP
13	28055	1	1" X 5" PIPE NIPPLE
14	28210	1	1" PIPE ELBOW
15	28060	1	2" X 5" PIPE NIPPLE
16	43760	1	BEARING
17	28351	1	1" X 3/4" REDUCER BUSHING
18	43153	1	IGNITOR
19	28273	1	2" PIPE CAP

CONTROL BOX ASSEMBLY

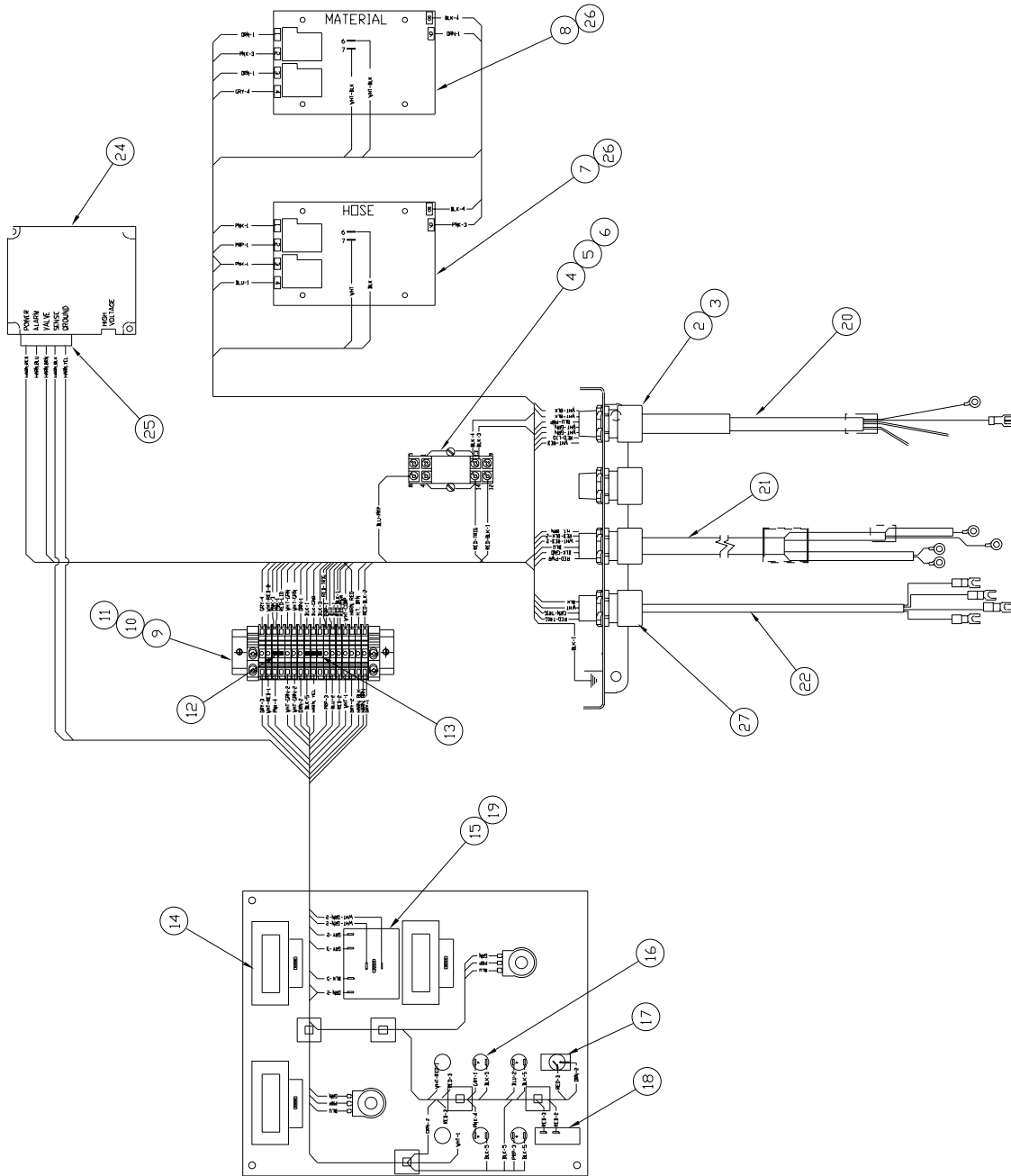

CONTROL BOX ASSEMBLY

NUMBER	PART NUMBER	QTY.	DESCRIPTION
1	44860	1	ENCLOSURE (NOT SHOWN)
2	40446	3	CORD CONNECTOR - "BLUE"
3	50280	3	1/2" CONDUIT NUT
4	51662	1	SOCKET - RELAY
5	51661	1	RELAY
6	51663	1	HOLD DOWN SPRING
7	51691	1	TEMPERATURE CONTROLLER, 400° / 325°
8	51672	1	TEMPERATURE CONTROLLER, 400° / 275°
9	51803	1	MOUNTING RAIL
10	51687	2	END BRACKET
11	51800	16	FEED THROUGH TERMINAL
12	51801	1	2-POLE JUMPER
13	51804	1	3-POLE JUMPER
14	50251	3	DIGITAL READOUT
15	43391	1	TEMPERATURE CONTROLLER, 150°-550°
16	51651	4	LIGHT, 12VDC
17	50719	1	TOGGLE SWITCH
18	51665	1	CIRCUIT BREAKER, 15 AMP
19	50593	3	KNOB
20	43926	1	CABLE ASSY. - SENSOR
21	43927	1	CABLE ASSY. - POWER
22	43928	1	CABLE ASSY. - TRIGGER/SENSOR
23	51684	2	RIBBON CABLE, 36" (NOT SHOWN)
24	25278	1	SPARK CONTROL MODULE
25	50559	1	WIRING HARNESS
26	51670	8	SPACER, PAK-STAT
27	51064	1	CORD CONECTOR 1/2"

GAS MANIFOLD ASSEMBLY

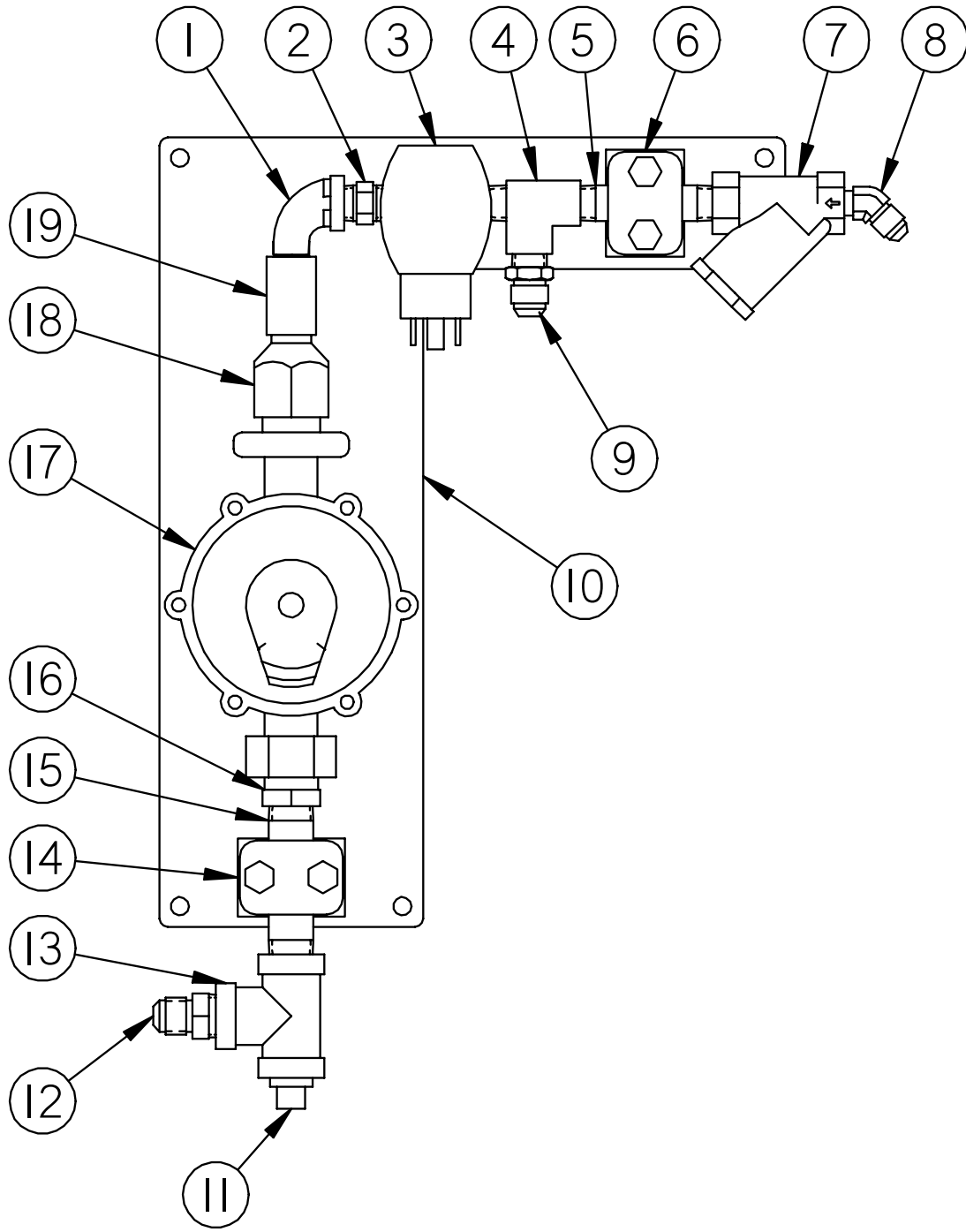

GAS MANIFOLD ASSEMBLY

NUMBER	PART NUMBER	QTY.	DESCRIPTION
1	28236	1	1/4 STREET ELBOW
2	51401	1	1/4 HEX PIPE NIPPLW
3	25236	1	GAS SOLENOID VALVE
4	29980	1	1/4 STREET TEE
5	28024	1	1/4 X 2 1/2 NIPPLE
6	45587	1	1/4 PIPE WELD ON CLAMP
7	25208	1	STRAINER
8	29857	1	1/4 NPT X 3/8 45° FLARE MALE
9	29839	1	1/4 NPT X 3/8 JIC ADAPTER
10	45593	1	GAS MANIFOLD MOUNTING PLATE
11	28282	1	3/8 PIPE PLUG
12	29840	1	CONNECTOR, 45° FLARE MALE
13	28252	1	3/8 PIPE TEE
14	45589	1	3/8 PIPE WELD ON CLAMP
15	28025	1	3/8 X 3.0 NIPPLE
16	28345	1	BUSHING, 1/2 X 3/8
17	45594	1	GAS MANIFOLD
18	45598	1	POL FEMALE X 1/4 MP
19	28176	1	1/4 PIPE COUPLING

POWER - PACK ASSEMBLY

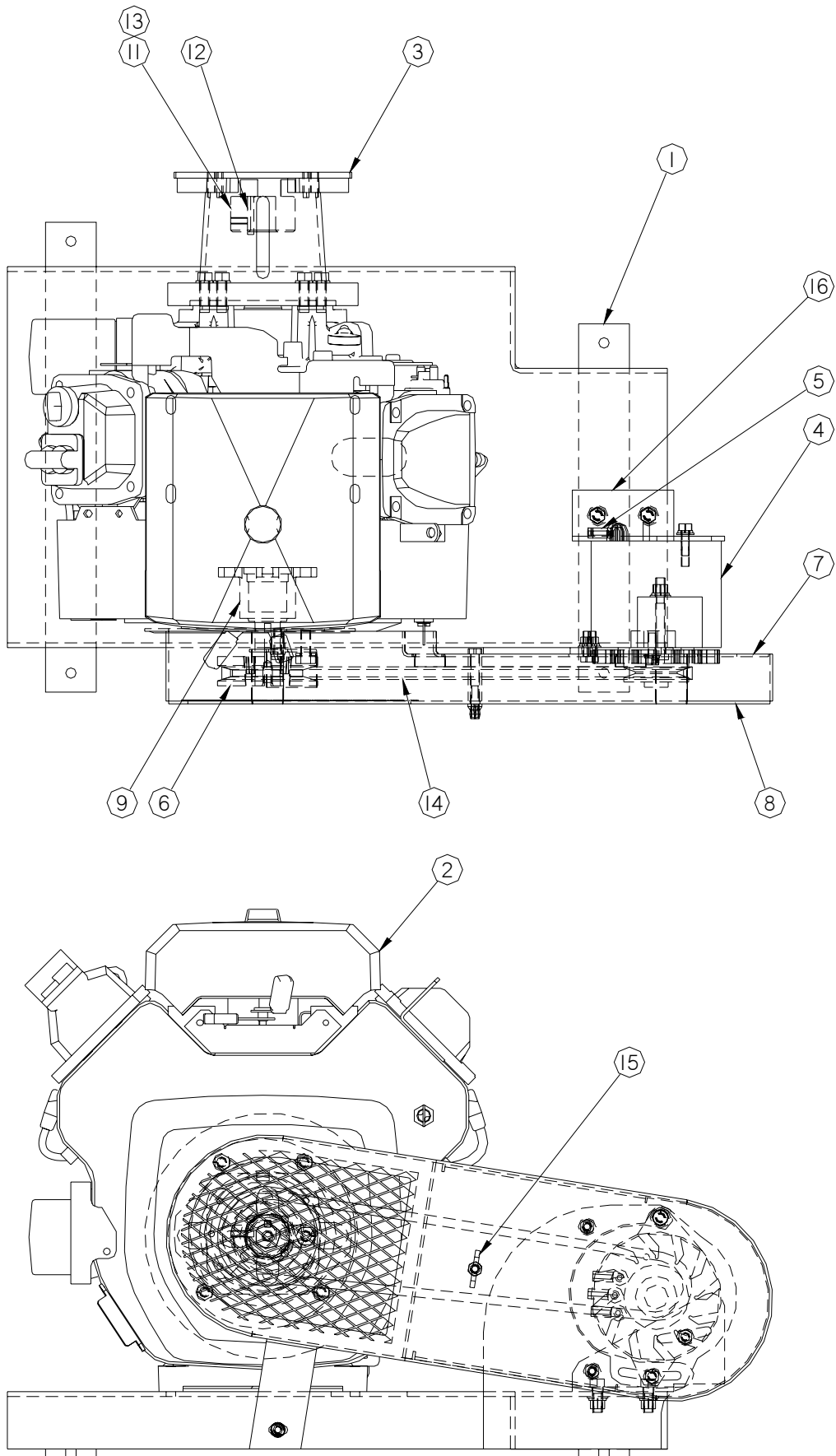

POWER - PACK ASSEMBLY

NUMBER	PART NUMBER	QTY.	DESCRIPTION
1	44309	1	MOUNTING BASE - ENGINE
2	44323	1	ENGINE, 20 HP
3	44379	1	HYD. PUMP ADAPTOR
4	43612	1	GENERATOR, 24 VAC
5	43887	3	TERMINAL BOOT
6	55340	1	PULLEY, DRIVE
7	44322	1	BELT GUARD - REAR
8	44320	1	BELT GUARD - OUTER
9	55341	1	DRIVE SHAFT, FRONT
10	29871	1	3/8 J X 1/4 NPT ELBOW (NOY SHOWN)
11	44829	1	1" BORE COUPLING
12	27017	1	SHAFT KEY
13	44830	1	SPIDER, COUPLING
14	43557	1	BELT, AX-39
15	28619	1	5/16-18 WING NUT
16	55358	1	ALTERNATOR BRACKET REAR SUPPORT

HYDRAULIC VALVE ASSEMBLY

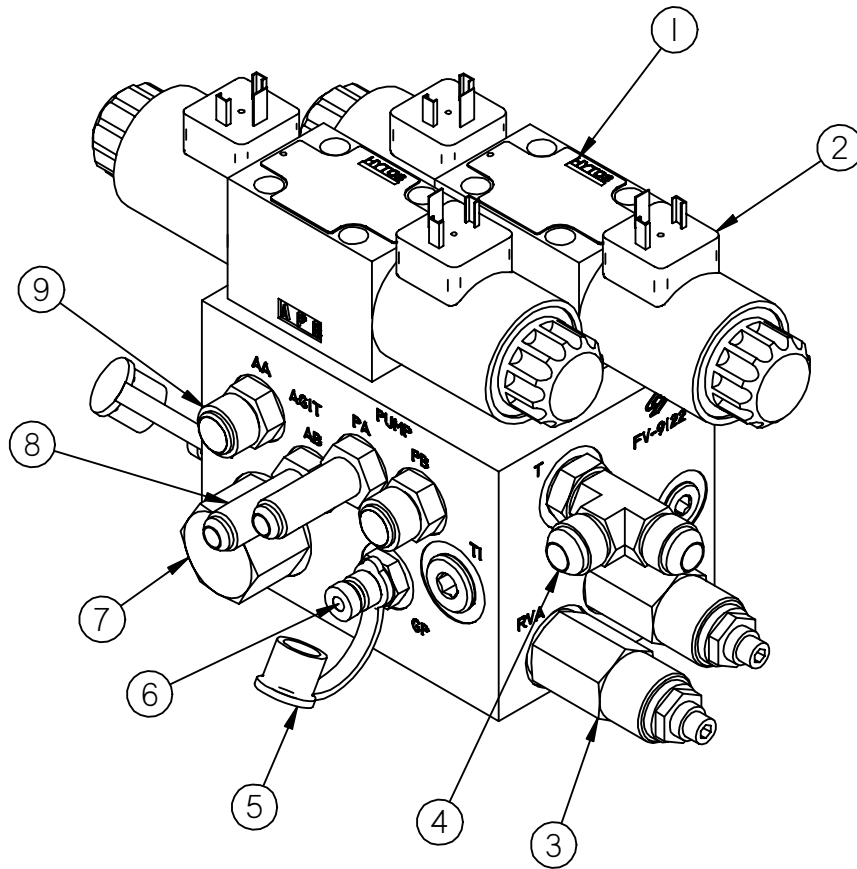

NUMBER	PART NUMBER	QTY.	DESCRIPTION
1	45418	2	VALVE, DIRECTIONAL
2	45419	4	COIL, DIRECTIONAL VALVE
3	45417	2	VALVE, RELIEF
4	29897	1	FITTING, #8 ORB X #8 MALE JIC STR
5	45413	2	CAP, DUST
6	45414	2	FITTING, TEST PORT
7	45416	1	FLOW CONTROL, PRIORITY
8	40308	2	FITTING, #6 ORB X #6 MALE JIC STR
9	29919	2	FITTING, #6 ORB X #8 MALE JIC STR

PUMP/AGITATOR ASSEMBLY

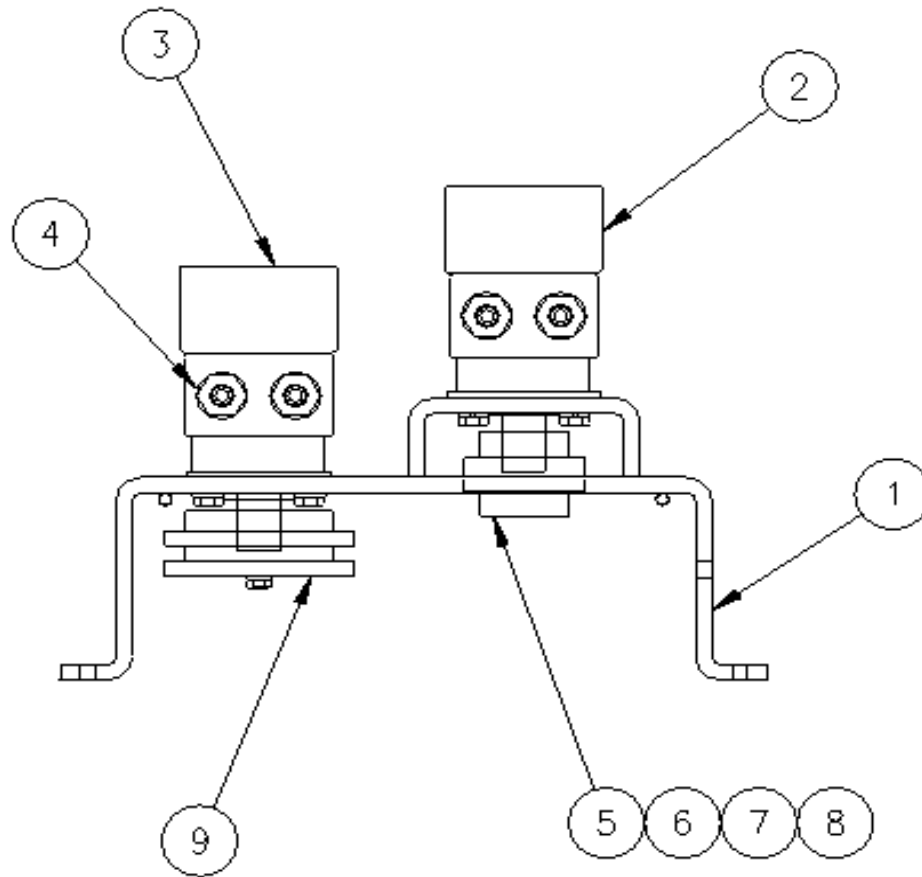

NUMBER	PART NUMBER	QTY.	DESCRIPTION
1	43345	1	MOTOR MOUNTING BRACKET
2	44809	1	HYDRAULIC MOTOR - PUMP
3	22027	1	HYDRAULIC MOTOR - AGITATOR
4	22029	4	O-RING ADAPTOR
5	26002	2	SPROCKET - CHAIN COUPLING
6	26016	1	CHAIN - COUPLING
7	26030	1	CONNECTING LINK - CHAIN
8	31368	1	KEY 1/4 X 1/4 X 7/8
9	43323	1	SPROCKET - AGITATOR DRIVE

BURNER ASSEMBLY

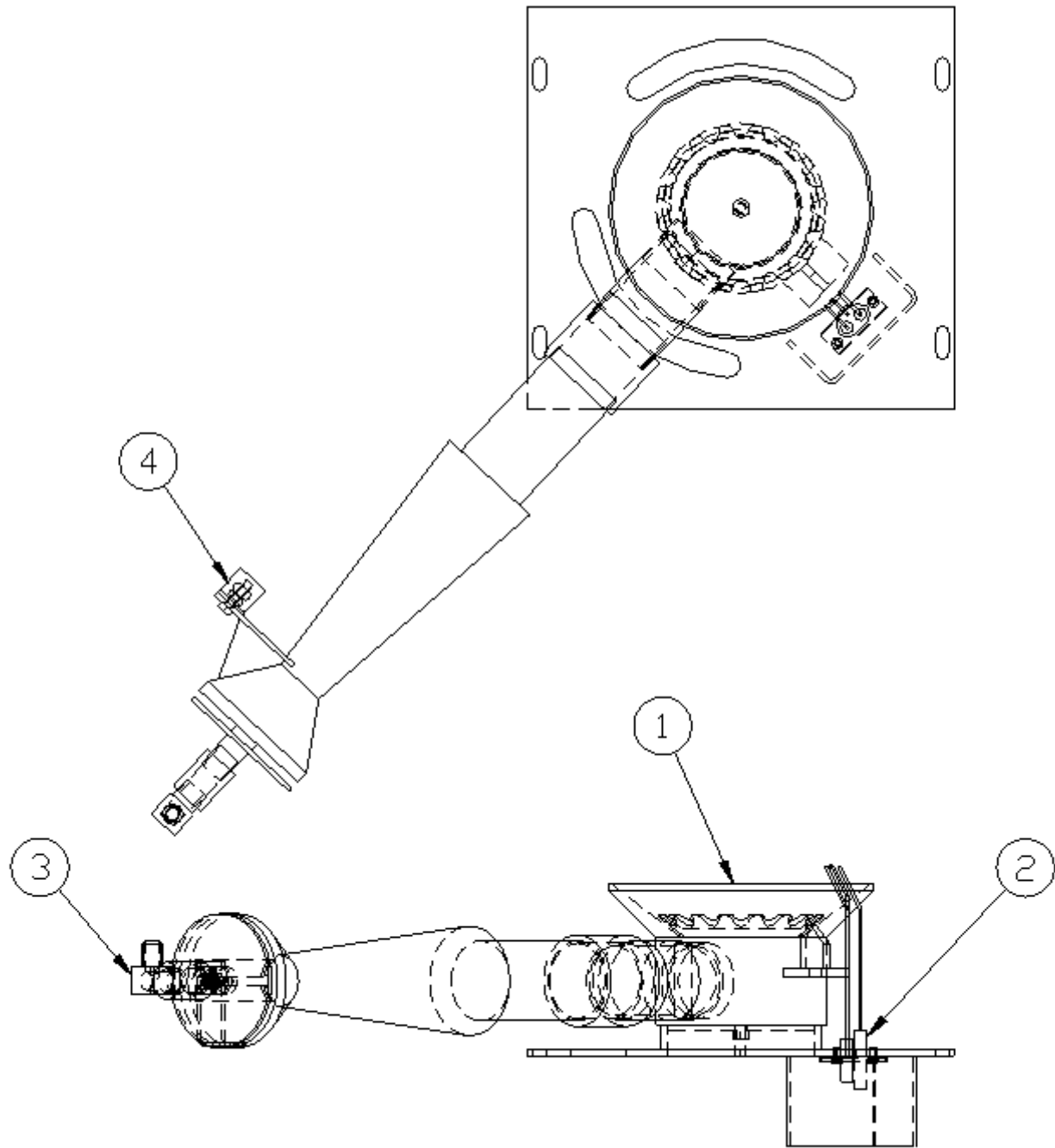

BURNER ASSEMBLY

1	43123	1	BURNER
2	43153	1	IGNITOR
3	29858	1	90° ELBOW
4	43109	1	MOUNTING BRACKET
5	-	1	ORFICE #26 (NOT SHOWN)

HYDRAULIC DIAGRAM

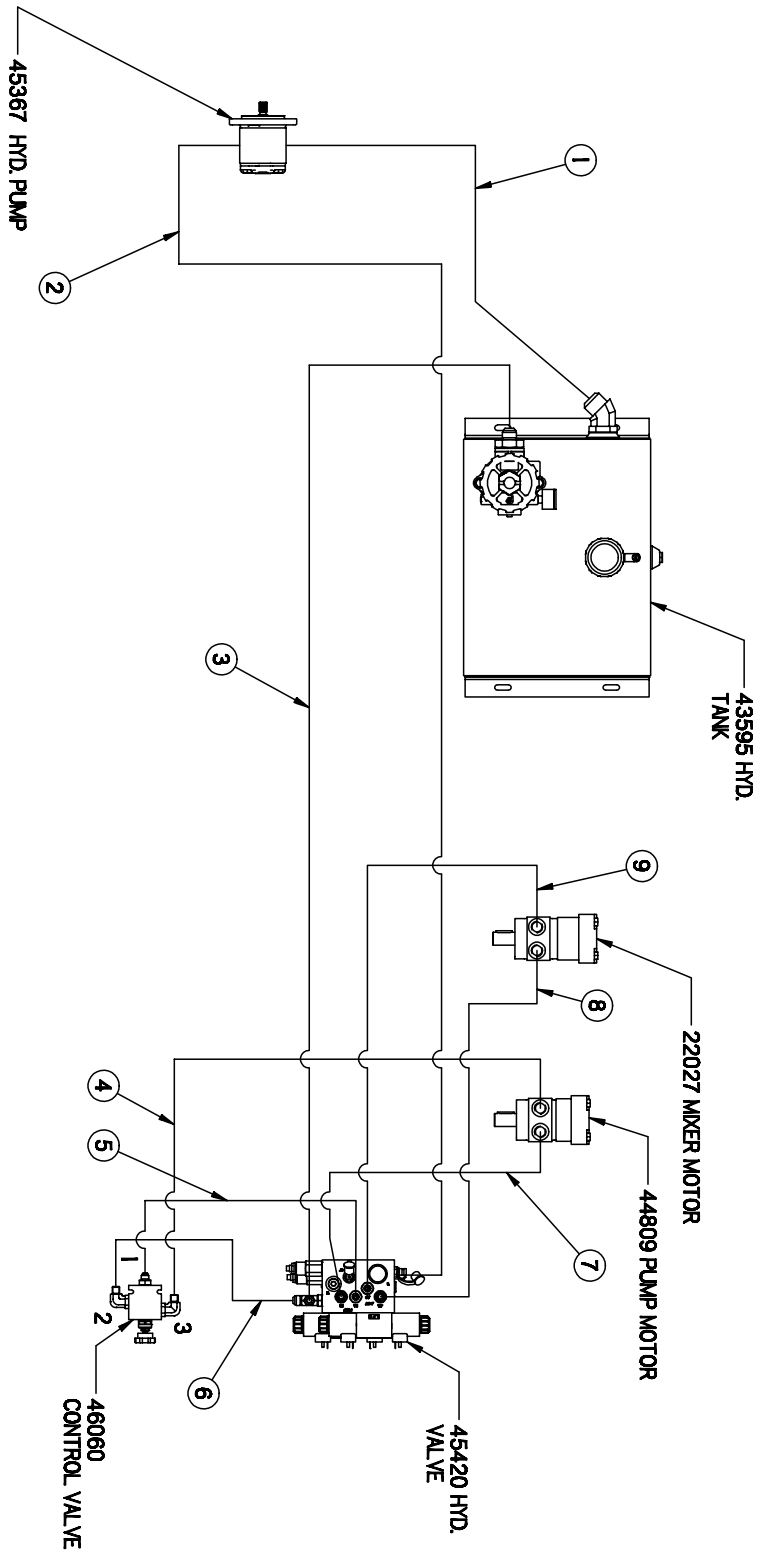

Flow = 7.0 GPM @ 2850 RPM
 Relief Valve Mixer (RVA) = 1000 PSI
 Relief Valve Pump (RVP) = 1000 PSI

HYDRAULIC DIAGRAM

1. HYD. RESERVIOR TO HYD. PUMP (SUCTION)		
1	29819	3/4 O-RING X 3/4 JIC ADAPTER
1	12G4H 12G-16FJX 12G-12FJX 36	HYD. HOSE ASSY., 3/4 X 36"
1	29931	3/4 TUBE X 1 5/16 O-RING ELBOW
2. HYD. PUMP "PRESS" PORT TO HYD. VALVE "P" PORT		
1	29862	5/8 TUBE X 5/8 O-RING ELBOW
1	8M3K 8G-10FJX 8G-8FJX90L 76	HYD. HOSE ASSY., 1/2 X 76"
1	29897	1/2 TUBE X 1/2 O-RING ADAPTER
3. HYD. VALVE "T" PORT TO HYD. FILTER		
1	----	1/2 O-RING X 1/2 RUN TEE
1	8M3K 8G-8FJX 8G-12FJX90S 84	HYD. HOSE ASSY., 1/2 X 84"
1	29991	3/4 TUBE X 1 1/4 O-RING ADAPTER
4. FLOW VALVE "3" TO MAT'L PUMP MOTOR		
1	29896	1/2 TUBE X 1/2 O-RING ELBOW
1	8M3K 8G-8FJX 8G-8FJX90L 28	HYD. HOSE ASSY., 1/2 X 28"
1	29913	1/2 TUBE X 5/8 O-RING ADAPTER
5. FLOW VALVE "1" TO HYD. VALVE "PA" PORT		
1	29897	1/2 TUBE X 1/2 O-RING ADAPTER
1	8M3K 8G-8FJX 8G-6FJX 24	HYD. HOSE ASSY., 1/2 X 24"
1	40308	3/8 TUBE X 3/8 O-RING ADAPTER
6. FLOW VALVE "2" TO HYD. VALVE "T" PORT		
1	29896	1/2 TUBE X 1/2 O-RING ELBOW
1	8M3K 8G-8FJX 8G-8FJX90S 30	HYD. HOSE ASSY., 1/2 X 30"
1	----	1/2 O-RING X 1/2 RUN TEE
7. HYD. VALVE "PB" PORT TO MAT'L PUMP MOTOR		
1	29919	1/2 TUBE X 1/2 O-RING ADAPTER
1	8M3K 8G-8FJX 8G-8FJX90S 15	HYD. HOSE ASSY., 1/2 X 15"
1	29913	1/2 TUBE X 5/8 O-RING ADAPTER
8. HYD. VALVE "AA" PORT TO MIXER MOTOR		
1	29919	1/2 TUBE X 1/2 O-RING ADAPTER
1	6M3K 6G-8FJX 6G-6FJX90S 22	HYD. HOSE ASSY., 3/8 X 22"
1	22029	3/8 TUBE X 5/8 O-RING ADAPTER
9. MIXER MOTOR TO HYD. VALVE "AB" PORT		
1	22029	3/8 TUBE X 5/8 O-RING ADAPTER
1	6M3K 6G-6FJX 6G-6FJX90L 23	HYD. HOSE ASSY., 3/8 X 23"
1	40308	3/8 TUBE X 3/8 O-RING ADAPTER

LPG SCHEMATIC

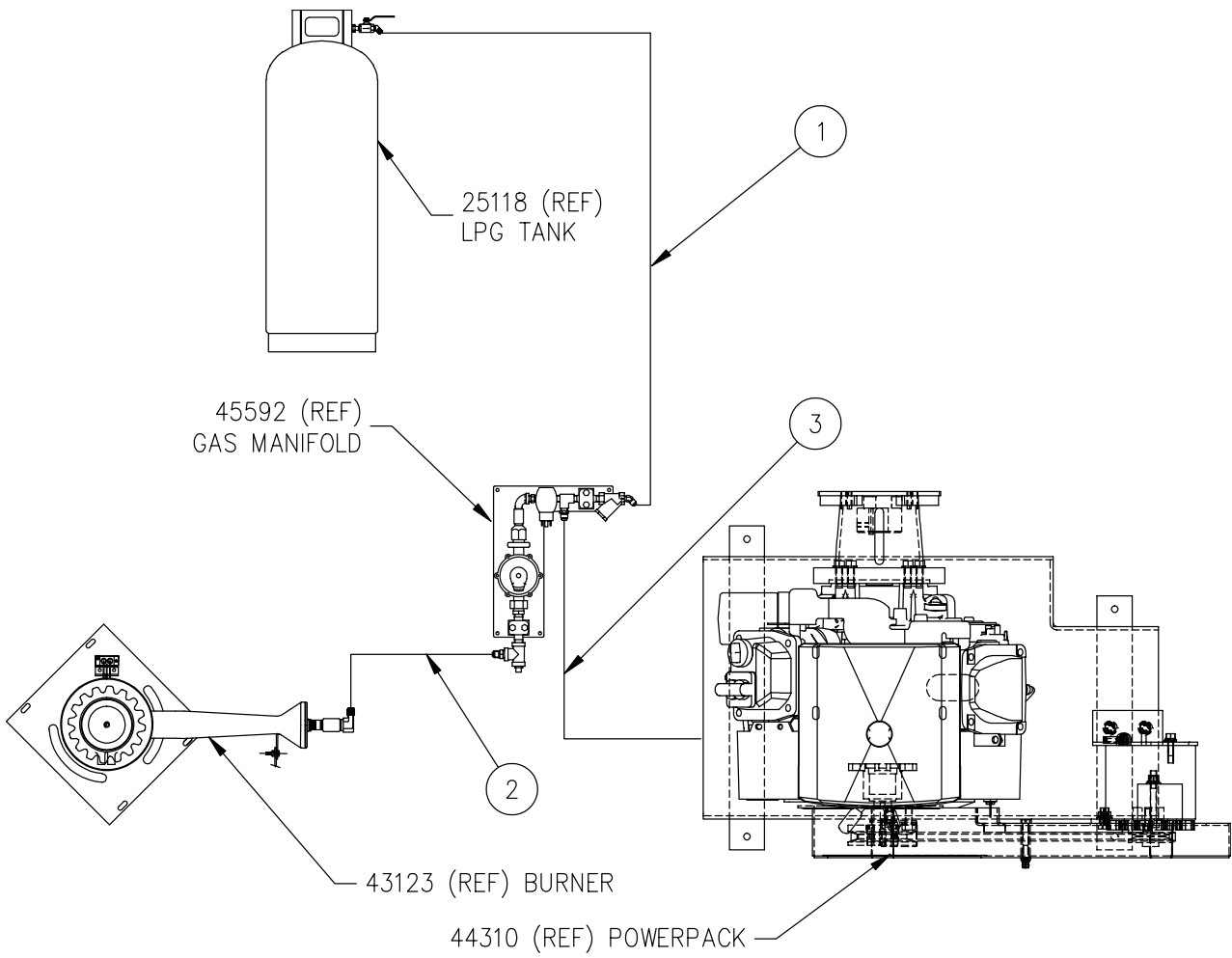

LPG SCHEMATIC

1. L.P.G. TANK TO MANIFOLD		
1	25074	SPUD ASSEMBLY, CONTAINS:
REF.	25123	TANK SPUD
REF.	29195	1/4 BALL VALVE
REF.	29857	3/8 TUBE X 1/4 NPT 45 ELBOW
1	LP6-60	HOSE ASSY., 3/8 X 60"
1	29839	3/8 TUBE X 1/4 NPT ADAPTOR
2. MANIFOLD TO BURNER		
1	43441	3/8 TUBE X 3/8 NPT ELBOW W/TEST PORT
1	LP6-S-17	FIREJACKET HOSE ASSY., 3/8 X 17"
1	29959	3/8 TUBE X 3/4 NPT FEM. ELBOW
3. MANIFOLD TO POWERPACK		
1	29839	3/8 TUBE X 1/4 NPT ADAPTOR
1	LP6-18	HOSE ASSY., 3/8 X 18"
1	29871	3/8 TUBE X 1/4 NPT ELBOW

ELECTRICAL SCHEMATIC

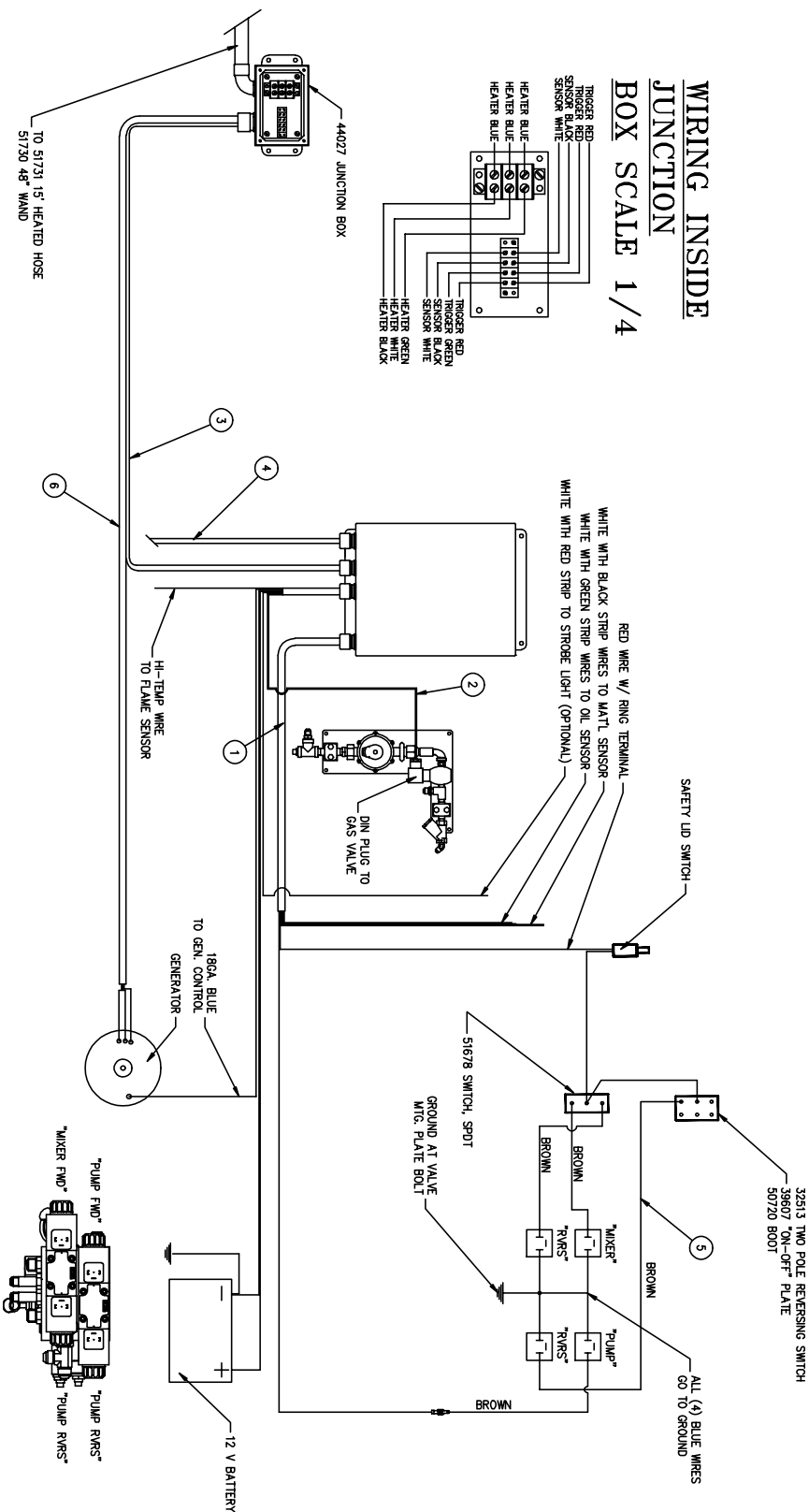

ELECTRICAL SCHEMATIC

NUMBER	PART NUMBER	QTY.	DESCRIPTION
1	43926	1	SENSOR CABLE
2	43929	1	POWER CABLE
3	43928	1	TRIGGER/SENSOR CABLE
4	50438	1	HI-VOLTAGE WIRE TO BURNER IGNITOR
5	43921	1	CABLE ASSY, VALVE
6	43900	1	HOSE CABLE
7	24015	1	BATTERY CABLE - BATT. TO STARTER SOLNOID
8	37038	1	BATTERY CABLE - GROUND BOLT TO ENGINE (NOT SHOWN)
9	32602	1	BATTERY CABLE - BATTERY TO GROUND BOLT (NOT SHOWN)

OPTIONAL SHOT TIMER ELECTRICAL SCHEMATIC

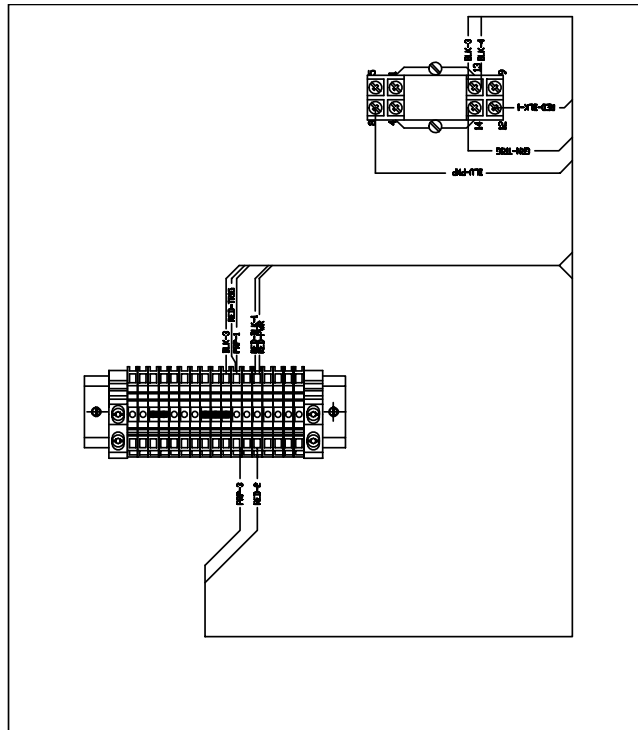

ENR10A
XCE CALINC. C5SS CAPACITORS

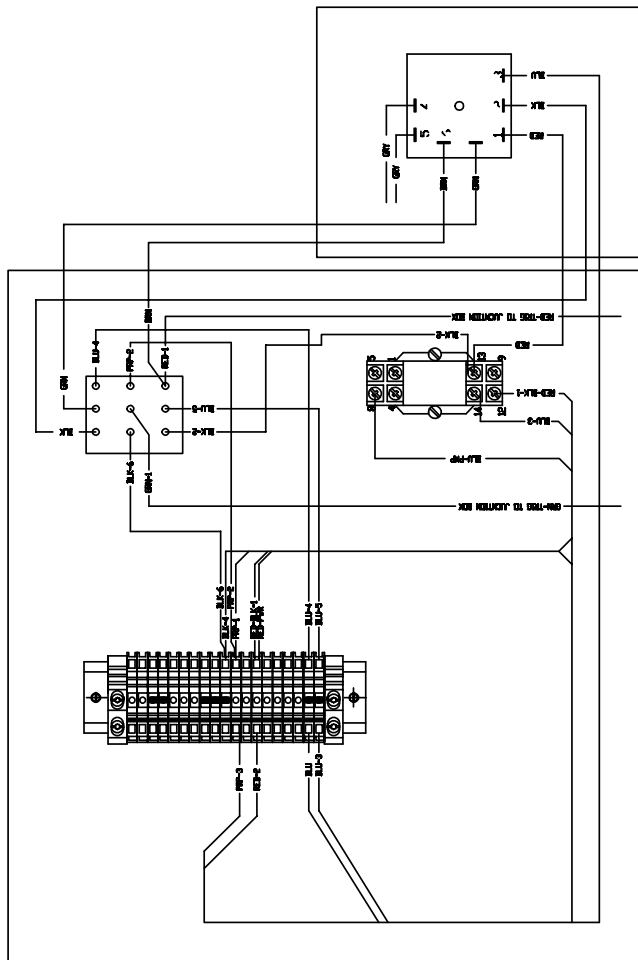

ENR10A
XCE 2-MILL ITEMS

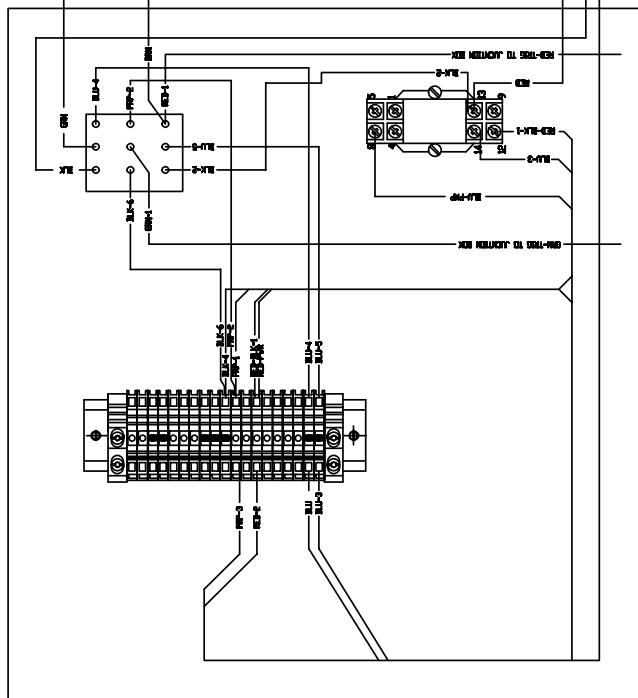

ENR10A
XCE CALINC. C5SS
XCE 2-MILL ITEMS

Pioneering Leadership and
Innovation in Quality
Pavement Maintenance
Products.



25527 S. Arizona Ave · Chandler, Arizona 85248
480-655-8333 · Watts 1-800-528-8242
Fax 480-655-1712

© Copyright 2002 by Crafco, Inc.