



## **SUPER SEALCOATER 550 & 800**

Parts Manual - 70319  
Revision D

Fill in appropriate fields that apply to this machine

Machine S/N: \_\_\_\_\_

1<sup>st</sup> Hose S/N: \_\_\_\_\_

2<sup>nd</sup> Hose S/N: \_\_\_\_\_

1<sup>st</sup> Pump S/N (material): \_\_\_\_\_

2<sup>nd</sup> Pump S/N (water): \_\_\_\_\_

Engine S/N: \_\_\_\_\_

Compressor S/N: \_\_\_\_\_

Gear Box S/N (Patcher): \_\_\_\_\_

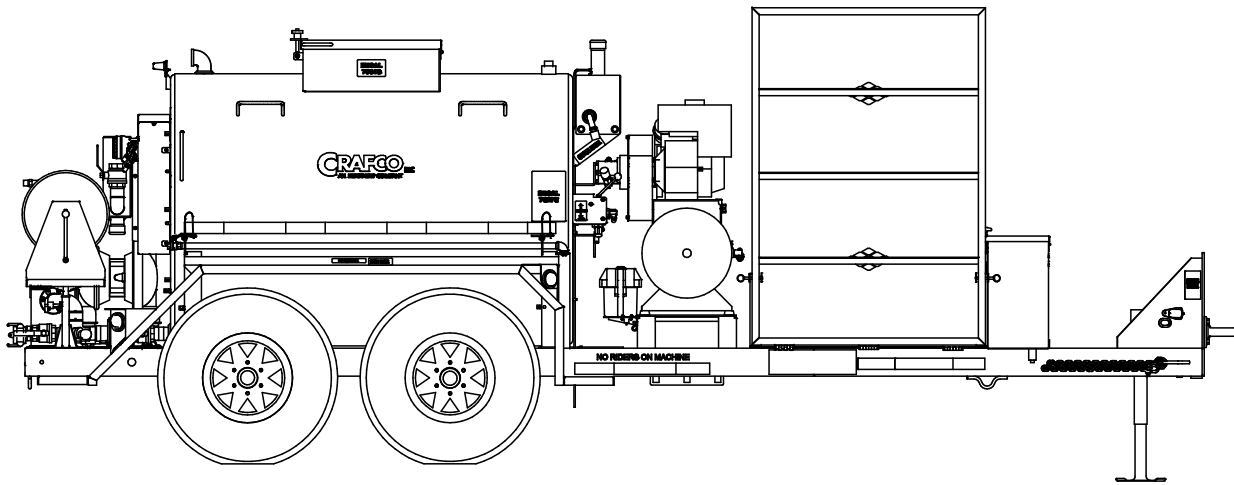
Blower S/N (Magnum): \_\_\_\_\_



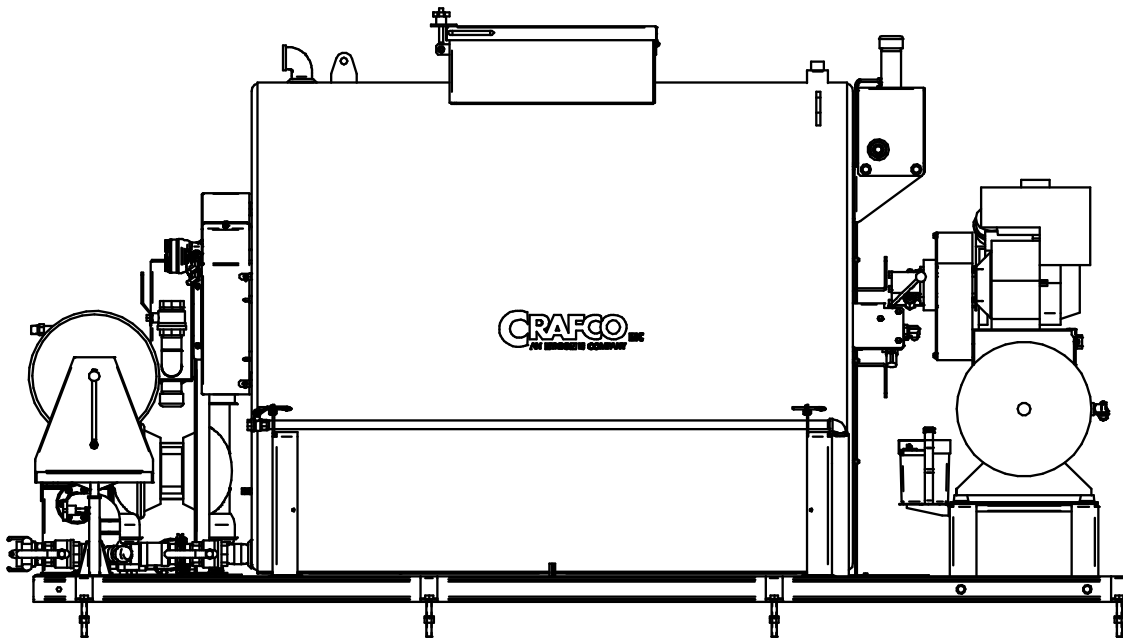
# Super Sealcoater 550 & 800 Part Manual

## Revisions

Rev	Description	Date
C	Updated format. Updated warranty. Changed hydraulic motor to 45428 from 70236. Changed drive sprocket 70238 to taper lock hub 70261. Updated tool names in Section 9.0. Updated figures in sections 8.2 – 8.4. Added website links for pump manuals in chapter 6. Added sections 2.4, 5.7, 5.10, 6.8, 8.18, 8.19, 8.20.	1/2019
D	Updated Table 6-6 with hydraulic oil full point information. Updated change hydraulic oil to every 500 hours of operation, Table 6-2.	4/2019



**SUPER SEALCOATER 500 GAL TRAILER  
PN 7000**



**SUPER SEALCOATER 800 GAL. SKID  
PN 70580**

## Table of Contents

1.0 About This Manual .....	1-1
1.1 How to use this manual: .....	1-1
2.0 Safety Precautions .....	2-1
2.1 General Safety.....	2-1
2.2 Personal Safety .....	2-1
2.3 Equipment or Operational Safety.....	2-1
2.4 California Proposition 65.....	2-2
2.4.1 All Crafco, Inc. Equipment.....	2-2
2.4.2 All Crafco, Inc. Equipment using a gasoline engine.....	2-2
2.5 Safety Symbols and Notices .....	2-3
3.0 Limited Warranty .....	3-1
3.1 Warranty Claim Instructions.....	3-2
4.0 Machine Specifications .....	4-1
4.1 Tank Depth Charts .....	4-2
5.0 Operating Instructions .....	5-1
5.1 Preparing the Machine for Start Up.....	5-1
5.2 Machine Start Up.....	5-2
5.3 Loading Material.....	5-3
5.3.1 Loading Material Using the On Board Material Pump.....	5-3
5.3.2 Loading Material Using an Alternative Pump .....	5-3
5.4 Agitating the Material.....	5-4
5.5 Recirculating the Material .....	5-4
5.6 Applying Material .....	5-4
5.6.1 Applying Material with the Hand Wand .....	5-4
5.6.2 Applying Material Using the Spray Bar.....	5-5
5.7 Cleaning out Material Hose and Hand Wand Using the Optional Water Tank.....	5-5
5.8 Clean out Spray Bar with Optional Water Tank.....	5-6
5.9 Draining Material Tank.....	5-6
5.10 Using the Optional Water Hose .....	5-6
5.11 Mounting a Skid Machine .....	5-9
5.12 Shutting Down the Machine .....	5-10
5.12.1 Shutting Down Overnight.....	5-10
5.12.2 Shutting Down Longer than 2 Days.....	5-10
6.0 Maintenance Instructions .....	6-1

## Table of Contents

6.1 Engine.....	6-1
6.2 Hydraulic System .....	6-1
6.3 Material Pump 2” .....	6-1
6.4 Water Pump 1/4” .....	6-1
6.5 Lug Nuts.....	6-1
6.6 Brakes.....	6-2
6.7 Tongue Jack.....	6-2
6.8 Agitator Drive Chain Tension.....	6-2
6.9 Cleaning the Sealcoater .....	6-3
6.10 Maintenance Chart .....	6-3
6.11 Service Instructions .....	6-4
6.12 General Maintenance Parts.....	6-4
6.13 Recommended Spare Parts .....	6-5
6.14 Recommended Fluids and Lubricants .....	6-5
7.0 How to Use a Multimeter.....	7-1
7.1 Checking DC Voltage with a Multimeter .....	7-1
7.2 Checking AC Voltage with Multimeter.....	7-1
7.3 Checking Resistance (Ohms).....	7-1
7.4 Checking Amperage.....	7-2
8.0 About the Illustrated Parts List .....	8-1
8.1 Ordering Crafcoc Parts .....	8-1
8.2 Super Sealcoater Passenger Side.....	8-2
8.3 Super Sealcoater Driver Side .....	8-4
8.4 Super Sealcoater Rear .....	8-6
8.5 Storage Deck Gate Lock .....	8-8
8.6 Hand Wand Storage Tab.....	8-9
8.7 Material Tank Hatch .....	8-11
8.8 Strainer Box .....	8-12
8.9 Hose Reel Stand .....	8-13
8.10 Hand Wand Assembly .....	8-14
8.11 Agitator Drive .....	8-16
8.12 Agitator.....	8-19
8.13 Hydraulic Drive .....	8-21
8.14 Material System.....	8-22
8.15 Optional Water System.....	8-24

## Table of Contents

8.16 Air System .....	8-30
8.17 Hydraulic System.....	8-34
8.18 Optional Operator Seat.....	8-39
8.19 Optional Manual Spray Bar Kit PN 70330K.....	8-40
8.19.1 Manual Spray Bar Assembly PN 70330 .....	8-41
8.20 Optional Automated Spray Bar Kit PN 70331K .....	8-42
8.20.1 Automated Spray Bar Assembly PN 70331.....	8-44
9.0 Tools and Accessories .....	9-1

## List of Figures

Figure 5.1 Air Compressor Engine .....	5-2
Figure 5.2 Sealcoater Valves and Water Hose .....	5-7
Figure 5.3 Air Compressor Valves .....	5-8
Figure 5.4 Material Valve #8 .....	5-8
Figure 6.1 Lug Bolt Tightening Sequence .....	6-1
Figure 6.2 Agitator Drive Chain Tension .....	6-2
Figure 7.1 Standard Multimeter.....	7-2
Figure 7.2 Clamp – On Amp Meter/Multimeter.....	7-3
Figure 8.1 Super Sealcoater Passenger Side .....	8-2
Figure 8.2 Super Sealcoater Driver Side.....	8-4
Figure 8.3 Super Sealcoater Rear .....	8-6
Figure 8.4 Storage Deck Gate Lock.....	8-8
Figure 8.5 Hand Wand Storage Tab .....	8-9
Figure 8.6 Material Tank Hatch.....	8-11
Figure 8.7 Strainer Box.....	8-12
Figure 8.8 Hose Reel Stand.....	8-13
Figure 8.9 Hand Wand Assembly Valve.....	8-14
Figure 8.10 Hand Wand Nozzle .....	8-15
Figure 8.11 Agitator Drive Chain.....	8-16
Figure 8.12 Agitator Drive Motor .....	8-17
Figure 8.13 Agitator Drive Bearing and Gasket.....	8-18
Figure 8.14 Agitator Assembly .....	8-19
Figure 8.15 Hydraulic Pump Without Cover .....	8-21
Figure 8.16 Material System .....	8-22
Figure 8.17 Optional Water Tank .....	8-24
Figure 8.18 Optional Water System Fittings.....	8-25
Figure 8.19 Optional Water System .....	8-26
Figure 8.20 Optional Water System (Continued).....	8-27
Figure 8.21 Optional Water System Rear Valves .....	8-28
Figure 8.22 Air System .....	8-30
Figure 8.23 Air System Regulator .....	8-32



**List of Figures**

Figure 8.24 Air System Diaphragm Pump .....	8-33
Figure 8.25 Hydraulic Tank .....	8-34
Figure 8.26 Hydraulic Pump With Cover .....	8-36
Figure 8.27 Hydraulic Control and Hoses.....	8-37
Figure 8.28 Agitator Drive Hydraulics.....	8-38
Figure 8.29 Optional Operator Seat .....	8-39
Figure 8.30 Manual Spray Bar Kit PN 70330K .....	8-40
Figure 8.31 Manual Spray Bar Assembly PN 70330 .....	8-41
Figure 8.32 Automated Spray Bar Kit PN 70331K.....	8-42
Figure 8.33 Automated Spray Bar PN 70331 .....	8-44

## List of Tables

Table 2-1 Safety Symbols and Notices .....	2-3
Table 2-2 Safety Symbols and Notices (continued).....	2-4
Table 4-1 Machine Specifications .....	4-1
Table 4-2 Seal Coater 550 Tank Depth Chart .....	4-2
Table 4-3 Seal Coater 550 Tank Depth Chart (continued) .....	4-3
Table 4-4 Seal Coater 800 Tank Depth Chart .....	4-4
Table 4-5 Seal Coater 800 Tank Depth Chart (continued) .....	4-5
Table 5-1 Preparing the Machine for Start Up.....	5-1
Table 5-2 Machine Start Up .....	5-2
Table 5-3 Loading Material Using the On Board Material Pump.....	5-3
Table 5-4 Loading Material Using an Alternative Pump.....	5-3
Table 5-5 Agitating the Material .....	5-4
Table 5-6 Recirculating the Material.....	5-4
Table 5-7 Applying Material with Hand Wand .....	5-4
Table 5-8 Applying Material with the Spray Bar .....	5-5
Table 5-9 Cleaning out Material Hose and Hand Wand .....	5-5
Table 5-10 Cleaning Out the Spray Bar .....	5-6
Table 5-11 Draining Material Tank.....	5-6
Table 5-12 Using the Optional Water Hose.....	5-6
Table 5-13 Mounting a Skid Machine.....	5-9
Table 5-14 Shutting Down Overnight .....	5-10
Table 5-15 Shutting Down Longer than 2 Days.....	5-10
Table 6-1 Agitator Drive Chain Tension Adjustment.....	6-2
Table 6-2 Maintenance Chart.....	6-3
Table 6-3 Service Instructions.....	6-4
Table 6-4 General Maintenance Parts .....	6-4
Table 6-5 Recommended Spare Parts.....	6-5
Table 6-6 Recommended Fluids and Lubricants .....	6-5
Table 8-1 Super Sealcoater Passenger Side .....	8-3
Table 8-2 Super Sealcoater Driver Side.....	8-5
Table 8-3 Super Sealcoater Rear .....	8-7

## List of Tables

Table 8-4 Storage Deck Gate Lock .....	8-8
Table 8-5 Hand Wand Storage Tab.....	8-9
Table 8-6 Material Tank Hatch .....	8-11
Table 8-7 Hydraulic Control Valve Assembly: PN 45420.....	8-12
Table 8-8 Hose Reel Stand.....	8-13
Table 8-9 Hand Wand Assembly Valve .....	8-14
Table 8-10 Hand Wand Nozzle .....	8-15
Table 8-11 Agitator Drive Chain .....	8-16
Table 8-12 Agitator Drive Motor .....	8-17
Table 8-13 Agitator Drive Bearing and Gasket .....	8-18
Table 8-14 Agitator Assembly .....	8-19
Table 8-15 Hydraulic Pump.....	8-21
Table 8-16 Material System .....	8-23
Table 8-17 Optional Water Tank .....	8-24
Table 8-18 Optional System Fittings .....	8-25
Table 8-19 Optional System.....	8-26
Table 8-20 Optional Water System (Continued).....	8-27
Table 8-21 Optional Water System Rear Valves .....	8-28
Table 8-22 Air System.....	8-31
Table 8-23 Air System Regulator .....	8-32
Table 8-24 Air System Regulator .....	8-33
Table 8-25 Hydraulic Tank .....	8-35
Table 8-26 Hydraulic Tank .....	8-36
Table 8-27 Hydraulic Control and Hoses.....	8-37
Table 8-28 Hydraulic Control and Hoses.....	8-38
Table 8-29 Optional Operator Seat .....	8-39
Table 8-30 Optional Spray Bar Kit PN 70330K.....	8-40
Table 8-31 Optional Spray Bar Assembly PN 70330.....	8-41
Table 8-32 Optional Automated Spray Bar Kit PN 70331K.....	8-43
Table 8-33 Automated Spray Bar PN 70331 .....	8-45



## Chapter 1 Introduction

### 1.0 About This Manual

This manual is supplied with each new Crafcoc Super Shot 60 Diesel Melter. The manual assists your machine operators in the proper use of the melter applicator and provides information about the machine's mechanical functions.

Your Crafcoc Super Shot 60 Diesel Melter is specially made to give excellent service and save maintenance expense. However, as with all specially engineered equipment, you get best results at minimum cost if you:

Operate your machine as instructed in this manual.

Maintain your machine regularly as stated in this manual.

### 1.1 How to use this manual:

This manual is formatted to start each new chapter on the right page. There may be a blank page on the left page if the previous chapter ends on the right page.

If you are viewing this in a digital format (PDF) the following features are available:

1. The Table of Contents, List of Tables, and List of Figures are all hyperlinks, when left mouse clicked on section, table, or figure you will be sent to that page.
2. The blue highlighted text throughout the manual is a hyperlink, when left mouse clicked you will be sent to that page, table, or figure.
3. The panel to the left in the PDF is a bookmarks panel, if you left mouse click on any section/heading in the bookmarks panel you will be sent to that page.



## Chapter 2 Safety

### 2.0 Safety Precautions

For more in-depth safety information, please see Safety Manual (PN 26221) which comes with the machine. Or contact your nearest authorized Crafco Distributor at [crafco.com/Distributors](http://crafco.com/Distributors).

### 2.1 General Safety

- Crafco, Inc. assumes no liability for an accident or injury incurred through improper use of the machine.
- Read this manual thoroughly before operating the machine.
- Obey all CAUTION and WARNING signs posted on the machine.
- Make sure an operator fully knows how to operate the machine before using the machine.

### 2.2 Personal Safety

- Always wear protective clothing, gloves, hard-soled shoes, and safety glasses or a face shield be worn at all times by operators of the machine.
- Bodily contact with hot sealant or heat transfer oil can cause severe burns.
- If the mixer is not stopped before adding material, it can get on an operator's body.
- Keep hands, feet, and clothing away from all moving parts.
- DO NOT point the nozzle at another person.
- DO NOT operate near an open flame.

### 2.3 Equipment or Operational Safety

- Do not operate the machine in buildings or work areas that do not have sufficient airflow.
- Shut-down the compressor engine before refilling the fuel tank.
- Make sure mixer stops before adding material to the tank. Lift the lid, place the material on the lid and close the lid. The mixer should restart automatically.
- Always keep a correctly maintained fire extinguisher near the machine and know how to use it.
- Replace any hoses which show signs of wear, fraying or splitting.
- Make sure all fittings and joints are tight and do not leak each time the machine is used.
- Do not leave the machine unattended while it is running.
- Tighten all bolts and screws every 100 hours of machine operation.
- DO NOT allow emulsion to freeze.
- DO NOT use any type of flame to unclog the emulsion hose or spray ring if they should become clogged.

## Chapter 2 Safety


### 2.4 California Proposition 65

The state of California currently maintains a list of chemicals that can cause cancer, birth defects or other reproductive harm. Your Crafco, Inc. equipment comes with the following warnings:

#### 2.4.1 All Crafco, Inc. Equipment

 **WARNING:** Cancer and Reproductive Harm - [www.P65Warnings.ca.gov](http://www.P65Warnings.ca.gov)  
26471N

#### 2.4.2 All Crafco, Inc. Equipment using a gasoline engine

 **WARNING:** Breathing engine exhaust exposes you to chemicals known to the State of California to cause cancer and birth defects or other reproductive harm.

- Always start and operate the engine in a well-ventilated area.
- If in an enclosed area, vent the exhaust to the outside.
- Do not modify or tamper with the exhaust system.
- Do not idle the engine except as necessary.

For more information go to [www.P65warnings.ca.gov/diesel](http://www.P65warnings.ca.gov/diesel).

26157








## Chapter 2 Safety

### 2.5 Safety Symbols and Notices





Important safety symbols and notices are marked on the machine and in this manual. Failure to comply could result in equipment damage, operational malfunction, serious injury, or death. Please read and comply with all symbols and notices. The table below includes the most commonly used symbols and notices.

**Table 2-1 Safety Symbols and Notices**

Symbol	Item	Remarks
<b>WARNING</b>	Warning	Refers to possible bodily injury or death.
<b>CAUTION</b>	Caution	Refers to possible equipment damage or operational malfunction.
	Severe Burn Hazard	Hot material can cause severe burns.
	Protective Shoes	Wear hard-soled work shoes.
	Protective Gloves	Wear heat resistant gloves.
	Protective Face or Eye Wear	Wear face shield or safety glasses.
	Body Crush Hazard	Do not stand between trailer and hitch when hooking melter to truck.

**Chapter 2 Safety**

**Table 2-2 Safety Symbols and Notices (continued)**

Symbol	Item	Remark
	Crush Hazard	Keep feet and legs clear.
	Pinch Hazard	Keep hands and feet clear.
	Exhaust Hazard	Avoid breathing engine exhaust.
	Read Manual	Read and understand operator and safety manuals before operating machine.

## Chapter 3 Warranty Information

### 3.0 Limited Warranty

Crafco, Inc. (Manufacturer), or one of its affiliated distributors, will replace for the original purchaser free of charge any parts found upon examination by the Manufacturer, to be defective in material or workmanship. This warranty is for a period **two years** from the invoice date, but excludes engine or components, tires, and battery as these items are subject to warranties issued by their manufacturers.

Crafco, Inc. shall not be liable for parts that have been damaged by accident, alteration, abuse, improper lubrication/maintenance, normal wear, or other cause beyond our control.

The warranty provided herein extends only to the repair and/or replacement of those components on the equipment covered above and does not cover labor costs. The warranty does not extend to incidental or consequential damages incurred as a result of any defect covered by this warranty.

All transportation and labor costs incurred by the purchaser in submitting or repairing covered components must be borne by the purchaser. Crafco, Inc. specifically disavows any other representation, warranty, or liability related to the condition or use of the product.

#### CAUTION

Use of replacement parts other than genuine Crafco parts may impair the safety or reliability of your equipment and nullifies any warranty.

## Chapter 3 Warranty Information

### 3.1 Warranty Claim Instructions

Crafco, Inc. warrants parts and machinery purchased through Crafco or one of its affiliated distributors for two years from the invoice date. Wear items are not covered under the Crafco, Inc. limited warranty. A wear item is defined as but not limited to: material pumps, sealing tips, tires, etc.

If parts fail to function within two years of invoice date, a return authorization number (RA) must be obtained. If the part was purchased through Crafco, Inc., please contact Crafco returns department at [Returns@Crafco.com](mailto>Returns@Crafco.com) for an RA number or if purchased through a Crafco distributor please contact your distributor.

Note: if the part has a serial number associated with it, for example; a machine or electric hose or wand, this must be furnished when requesting the RA number. The customer will be emailed or faxed an RA form with all instructions to return the item to Crafco, Inc. See example. If the part is found to be within the two year warranty period and has not been abused or modified, a credit will be issued to the customer's account or credit card. The customer may request the part be replaced instead of a credit, if desired.

Note: All engine warranties are covered through the engine manufacturer. If you need information for a distributor in your area please contact us and we will direct you to the closest engine distributor.

All parts returned are tested and evaluated. If the part has been modified in any way without prior consent from a Crafco, Inc. representative, warranty is void.

Please follow the instructions stated below when calling in a Warranty Claim. Failure to follow these procedures may be cause to void the warranty.

Call your local Crafco Distributor. If you do not know who your local distributor is, call a Crafco Customer Service Representative, (Toll Free 1-800-528-8242) for name, location and telephone number.

On contacting the distributor, be prepared to identify the serial number, model number, engine number, engine manufacturer, and the date of purchase if available.

Should the cause of the malfunction be a defective part, the Distributor will advise you of the procedure to follow for a replacement.

The warranty is valid only for parts, which have been supplied or recommended by Crafco, Inc.

If you have any additional questions regarding warranty repairs and parts, please do not hesitate to call toll free 1-800-528-8242.

For Warranty:  
Crafco, Inc.  
25527 South Arizona Avenue, Chandler, AZ  
85248  
Phone: (480) 655-8333 or (800) 528-8242  
Fax: (480) 655-1712

For all other inquires:  
Crafco, Inc.  
6165 W Detroit Street  
Chandler, AZ 85226  
Phone: (602) 276-0406 or (800) 528-8242  
Fax: (480) 961-0513  
[CustomerService@crafco.com](mailto:CustomerService@crafco.com)

## Chapter 4 Machine Specifications

### 4.0 Machine Specifications

**Table 4-1 Machine Specifications**

Specification	PN 70000, 550 TRAILER	PN 70500, 800 TRAILER	PN 70580, 800 SKID
Tank Capacity	550 Gal	800 Gal	800 Gal.
Tank Opening Size	24 in. by 24 in. (60.9 cm), 576 sq. in. area (3716 square cm)		
Drive Mechanism	Hydraulic with infinite adjust		
Agitator	Full sweeping horizontal three paddle agitator with rubber wipers		
Hydraulic Tank	6.7 Gal. (25.4 L)		
Air compressor tank	Jenny 30 Gal tank		
Material Pump	2" diaphragm pump		
Gas Engine	Honda 13hp GX390		
Fuel Tank Capacity	1.4 Gal. (5.3 L)		
Air Compressor	20 CFM		
Dry Weight Approximately	4,080 Lbs.	4,280 Lbs.	2,400 Lbs.
Axle Capacity	Dual 6000 Lbs.	Dual 7000 Lbs.	N/A
Tires	ST235/80R16		N/A

## Chapter 4 Machine Specifications

### 4.1 Tank Depth Charts

**Table 4-2 Seal Coater 550 Tank Depth Chart**

Seal Coater 550		
DEPTH OF MATERIAL TANK	CAPCITY (GALLONS)	CAPACITY (LITERS)
1	2.82	10.67
2	7.93	30.02
3	14.49	54.85
4	22.17	83.92
5	30.78	116.51
6	40.19	152.14
7	50.30	190.41
8	61.03	231.02
9	72.31	273.72
10	84.09	318.32
11	96.29	364.50
12	108.92	412.31
13	121.89	461.40
14	135.18	511.71
15	148.75	563.08
16	162.57	615.39
17	176.61	668.54
18	190.83	722.37
19	205.22	776.84
20	219.73	831.77
21	234.35	887.11
22	249.05	942.76
23	263.80	998.59
24	278.58	1054.54
25	293.35	1110.45
26	308.10	1166.29
27	322.80	1221.93
28	337.41	1277.24
29	351.93	1332.20
30	366.32	1386.67
31	380.54	1440.50
32	394.58	1493.65
33	408.40	1545.96
34	421.97	1597.33
35	435.26	1647.64
36	448.23	1696.74
37	460.84	1744.47

## Chapter 4 Machine Specifications

**Table 4-3 Seal Coater 550 Tank Depth Chart (continued)**

<b>Seal Coater 550</b>		
<b>DEPTH OF MATERIAL TANK</b>	<b>CAPACITY (GALLONS)</b>	<b>CAPACITY (LITERS)</b>
38	473.06	1790.73
39	484.84	1835.32
40	496.12	1878.02
41	506.85	1918.64
42	516.96	1956.91
43	526.37	1992.53
44	534.98	2025.12
45	542.66	2054.19
46	549.21	2078.99
47	554.33	2098.37
48	557.16	2109.08

## Chapter 4 Machine Specifications

**Table 4-4 Seal Coater 800 Tank Depth Chart**

<b>Seal Coater 800</b>		
<b>DEPTH OF MATERIAL TANK</b>	<b>CAPACITY (GALLONS)</b>	<b>CAPACITY (LITERS)</b>
1	3.10	11.73
2	8.74	33.08
3	15.99	60.53
4	24.48	92.67
5	34.03	128.82
6	44.49	168.41
7	55.75	211.04
8	67.74	256.42
9	80.36	304.20
10	93.58	354.24
11	107.33	406.29
12	121.57	460.19
13	136.25	515.76
14	151.35	572.92
15	166.81	631.44
16	182.61	691.25
17	198.73	752.27
18	215.12	814.32
19	231.77	877.34
20	248.64	941.20
21	265.71	1005.82
22	282.96	1071.12
23	300.36	1136.99
24	317.90	1203.38
25	335.54	1270.16
26	353.26	1337.23
27	371.05	1404.58
28	388.89	1472.11
29	406.74	1539.68
30	424.60	1607.29
31	442.43	1674.78
32	460.22	1742.12
33	477.95	1809.24
34	495.59	1876.01
35	513.12	1942.37
36	530.52	2008.24
37	547.77	2073.54



## Chapter 4 Machine Specifications

**Table 4-5 Seal Coater 800 Tank Depth Chart (continued)**

<b>Seal Coater 800</b>		
<b>DEPTH OF MATERIAL TANK</b>	<b>CAPACITY (GALLONS)</b>	<b>CAPACITY (LITERS)</b>
38	564.85	2138.19
39	581.72	2202.05
40	598.36	2265.04
41	614.76	2327.12
42	630.87	2388.10
43	646.67	2447.91
44	662.14	2506.47
45	677.23	2563.59
46	691.91	2619.16
47	706.15	2673.07
48	719.90	2725.12
49	733.12	2775.16
50	745.75	2822.97
51	757.73	2868.32
52	769.00	2910.98
53	779.45	2950.54
54	789.00	2986.69
55	797.50	3018.87
56	804.74	3046.27
57	810.38	3067.62
58	813.48	3079.36



**Chapter 5 Operating Instructions**

**5.0 Operating Instructions**


The CrafcO Super Sealcoater 550 or 800 is designed to give excellent service and save maintenance expense. However, as with all specifically engineered equipment, you can get the best results at minimum cost if you operate your machine as instructed, and maintain it regularly as instructed in this manual.

**Note:** DO NOT attempt to operate the machine without using these and all other instructions.

**5.1 Preparing the Machine for Start Up**

The CrafcO Super Sealcoater 550 / 800 are fully serviced and tested prior to shipment. However, shipping regulations do not allow shipment of a fully serviced unit. The following should be checked prior to operation:

Table 5-1 Preparing the Machine for Start Up

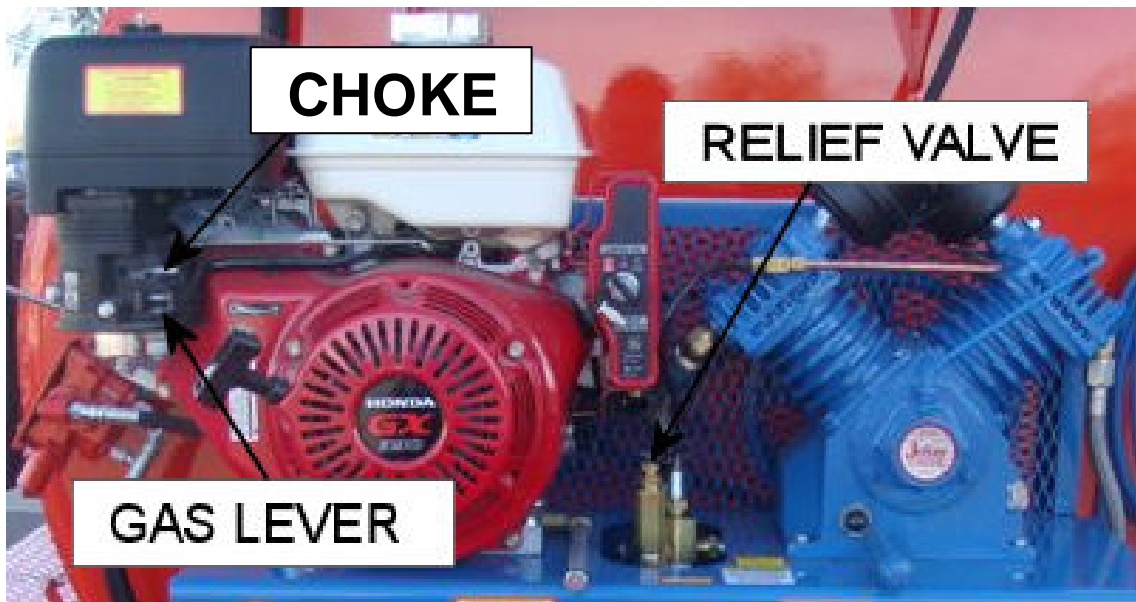
Step	Action
1	Fill gasoline fuel tank located on the air compressor unit.
2	Check oil sight gauge daily for the air compressor pump. Add if required. Read the compressor manufacturer's manual supplied with the unit for maintenance.
3	Check engine oil level daily. Add if required.
4	Check oil level daily. Add if required
<b>WARNING</b>	
	<p>The safe operation of this machine is the operator's responsibility. Use extreme care when operating this machine; safety is the result of being careful and paying attention to details.</p> <p>Always put on protective clothing, gloves, hard-soled shoes, and safety glasses or a face shield. Be sure that all joints and fittings are tight and leak proof. Immediately replace any hose, which shows any signs of wear, fraying, or splitting. Tighten all bolts, nuts, and screws every 100 hours.</p>

**Chapter 5 Operating Instructions**

**5.2 Machine Start Up**

**Table 5-2 Machine Start Up**

<b>Step</b>	<b>Action</b>
1	Make sure all material, air, and water valves are in the closed position.
2	Make sure the hydraulic metering valve is in the neutral position.
3	Open the relief valve on the compressor unit as shown in <a href="#">Figure 5.1</a> This unloads the pressure on the heads of the compressor pump.
4	Move the grey choke lever on the compressor engine, as shown in <a href="#">Figure 5.1</a> , to the “choke” position.
5	Move the black gas lever on the compressor engine, located just below the grey choke lever shown in <a href="#">Figure 5.1</a> to the on position.
6	Turn the ignition key on the compressor engine to the start position. When the engine turns over and begins running, slide the grey choke lever from the “choke” position to the “off choke” position.
7	Close the relief valve on the compressor unit.
8	Let the compressor unit run until it idles down. When this happens the air tank is full and ready for operation.



**Figure 5.1 Air Compressor Engine**

## Chapter 5 Operating Instructions

### 5.3 Loading Material

The Crafco, Inc. Super Sealcoater is equipped with an on board material pump. An alternative pump may also be used. Follow these steps to load material in the machine.

#### CAUTION

These steps are assuming that valves are closed, the air compressor is running, the air tank is full, and strainer box lid is tightened down

#### 5.3.1 Loading Material Using the On Board Material Pump

**Table 5-3 Loading Material Using the On Board Material Pump**

Step	Action
1	Open air valve #6. See <a href="#">Figure 5.3</a>
2	Set the air regulator to the desired pressure.
3	Remove cam lock cap, and attach a 2" hose to the cam lock fitting just in front of material valve #2. See <a href="#">Figure 5.2</a>
4	Make sure the lid on the strainer box is screwed down tight
5	Open material valve #2.
6	Open material valve #4.
7	To begin pumping, open air valve #7.
8	Pump material into tank until desired level is reached.
9	Close all valves.
10	Disconnect hose, and replace the cam lock cap.

#### 5.3.2 Loading Material Using an Alternative Pump

**Table 5-4 Loading Material Using an Alternative Pump**

Step	Action
1	Open tank hatch and pump material into tank until desired level is reached. OR Remove cam lock cap, and attach a 2" hose to the cam lock fitting just in front of material valve #2. See <a href="#">Figure 5.2</a>
2	Open material valve #1.
3	Open material valve #2.
4	Pump material into tank until desired level is reached.
5	Close all valves.
6	Disconnect hose, and replace the cam lock cap.

## Chapter 5 Operating Instructions

### 5.4 Agitating the Material

**Table 5-5 Agitating the Material**

Step	Action
1	Make sure the compressor unit engine is running.
2	Engage the hydraulic metering valve up to move the agitator in a clockwise rotation or down to move the agitator in a counterclockwise rotation. The agitator speed is determined by the position of the handle. The more the handle is moved away from the neutral position the faster the agitator will turn.
3	To stop the agitator, return the hydraulic valve to the neutral position.

### 5.5 Recirculating the Material

**Table 5-6 Recirculating the Material**

Step	Action
1	Open air valve #6. See <a href="#">Figure 5.3</a>
2	Set the air regulator to the desired pressure.
3	Open material valve #1. See <a href="#">Figure 5.2</a>
4	Open material valve #4.
5	Open air valve #7.
6	When finished close all valves.

### 5.6 Applying Material

The Crafco, Inc. Super Sealcoater includes two ways to apply the material, a hand wand, and a spray bar. Follow these steps to apply the material

#### 5.6.1 Applying Material with the Hand Wand

**Table 5-7 Applying Material with Hand Wand**

Step	Action
1	Open air valve #6. See <a href="#">Figure 5.3</a>
2	Set the air regulator to the desired pressure.
3	Open material valve #1. See <a href="#">Figure 5.2</a>
4	Open material valve #3.
5	Open and close material valve #8 to control the spray out of the hand wand. See <a href="#">Figure 5.4</a>
6	When finished close all valves.

## Chapter 5 Operating Instructions

### 5.6.2 Applying Material Using the Spray Bar

**Table 5-8 Applying Material with the Spray Bar**

Step	Action
1	Open air valve #6. See <a href="#">Figure 5.3</a>
2	Set the air regulator to the desired pressure.
3	Open material valve #1. See <a href="#">Figure 5.2</a>
4	Open material valve #5.
5	Use air switch on automated spray bar, or valves on manual spray bar to start and stop spray.
6	When finished spraying close all valves.

### 5.7 Cleaning out Material Hose and Hand Wand Using the Optional Water Tank

If machine is equipped with the optional on board water tank, follow the below instruction to clean out the material hose and wand after every use.

**Table 5-9 Cleaning out Material Hose and Hand Wand**

Step	Action
	Follow the steps below starting with all valves in the closed position.
1	Return the agitator control valve to the neutral position.
2	Open air valve #6. See <a href="#">Figure 5.3</a>
3	Set the air regulator to the desired pressure.
4	Open material tank hatch lid, and splash lid.
5	Remove sand grating.
6	Stick the spray nozzle end of the hand wand into the material tank.
7	Open water valve #9. See <a href="#">Figure 5.2</a>
8	Open material valve #3.
9	Open air valve #7.
10	Open material valve #8 and spray into material tank until water comes out of the hand wand. See <a href="#">Figure 5.4</a>
11	When finished close all valves.

## Chapter 5 Operating Instructions

### 5.8 Clean out Spray Bar with Optional Water Tank

If machine is equipped with the optional on board water tank, follow the below instruction to clean out the spray bar after every use.

**Table 5-10 Cleaning Out the Spray Bar**

Step	Action
	Follow the steps below starting with all valves in the closed position.
1	Return the agitator control valve to the neutral position.
2	Open air valve #6. See <a href="#">Figure 5.3</a>
3	Set the air regulator to the desired pressure.
4	Open water valve #9. See <a href="#">Figure 5.2</a>
5	Open material spray bar valve #5.
6	Open air valve #7.
7	Activate automated spray bar switch, or open spray valves on manual spray bar until water runs clean.
8	When finished, close all valves.

### 5.9 Draining Material Tank

**Table 5-11 Draining Material Tank**

Step	Action
1	Remove cam lock cap, and attach a 2" hose to the cam lock fitting just in front of material valve #2. See <a href="#">Figure 5.2</a>
2	Open material valve #1.
3	Let material tank drain.
4	When finished close all valves and replace cam lock cap.

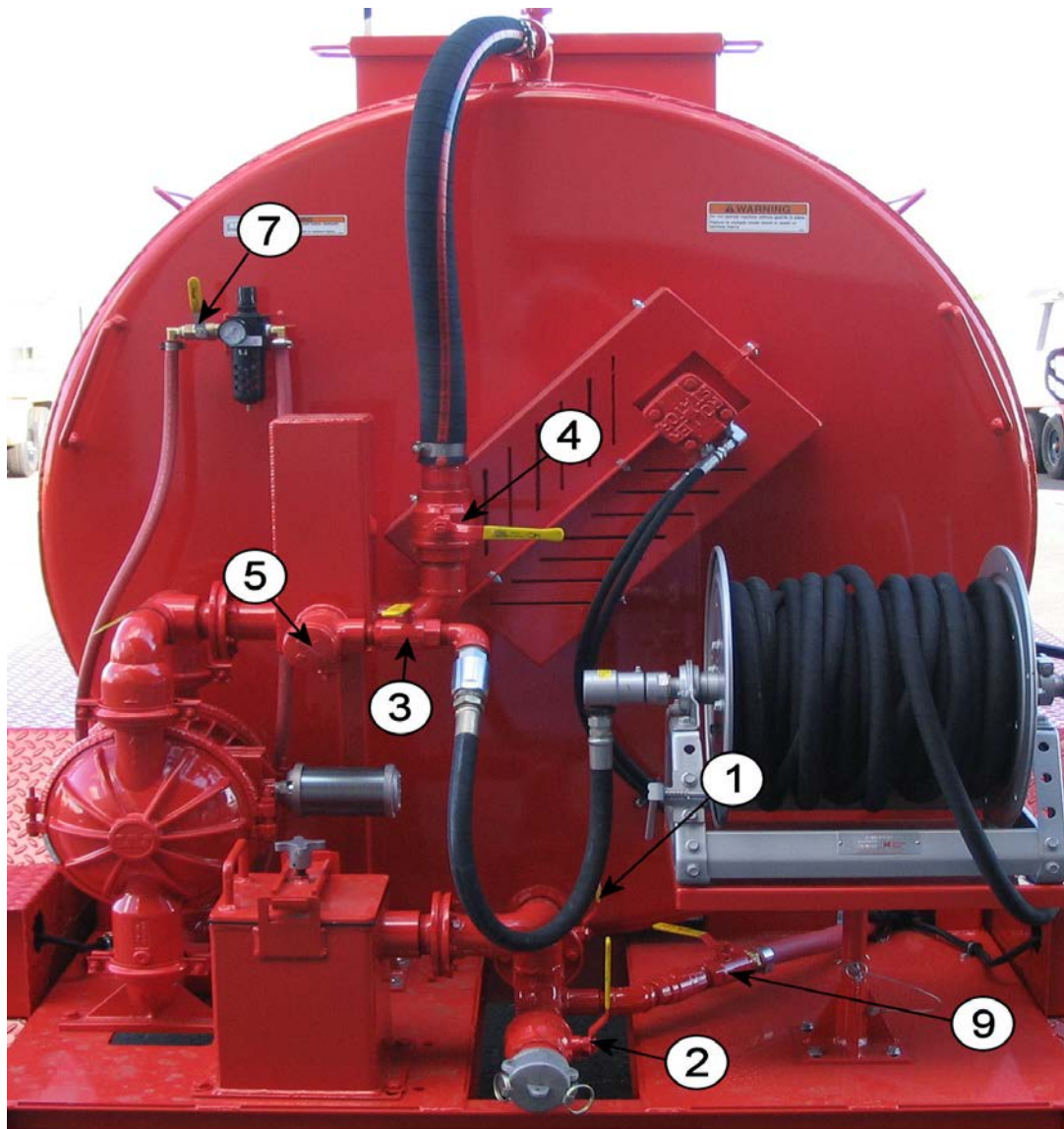
### 5.10 Using the Optional Water Hose

**Table 5-12 Using the Optional Water Hose**

Step	Action
1	Open air valve #10. See <a href="#">Figure 5.3</a>
2	Squeeze and release water nozzle #11 to control spray out the end of the nozzle
3	When finished close all valves.

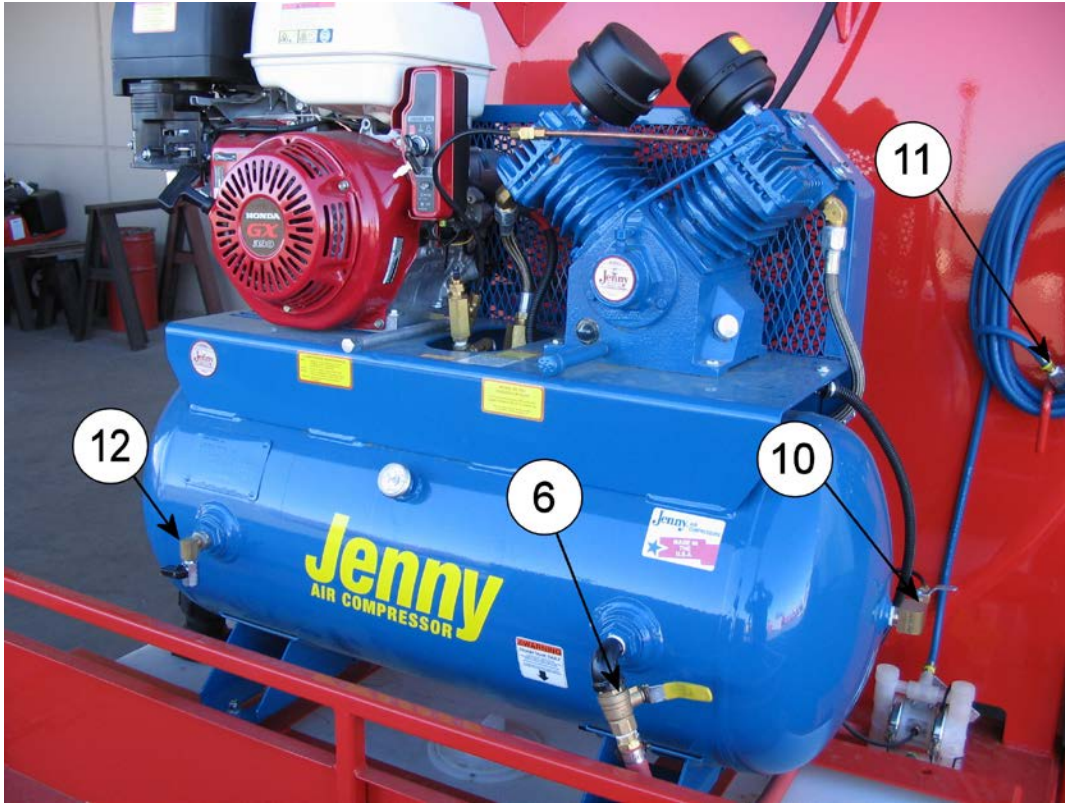


## Chapter 5 Operating Instructions

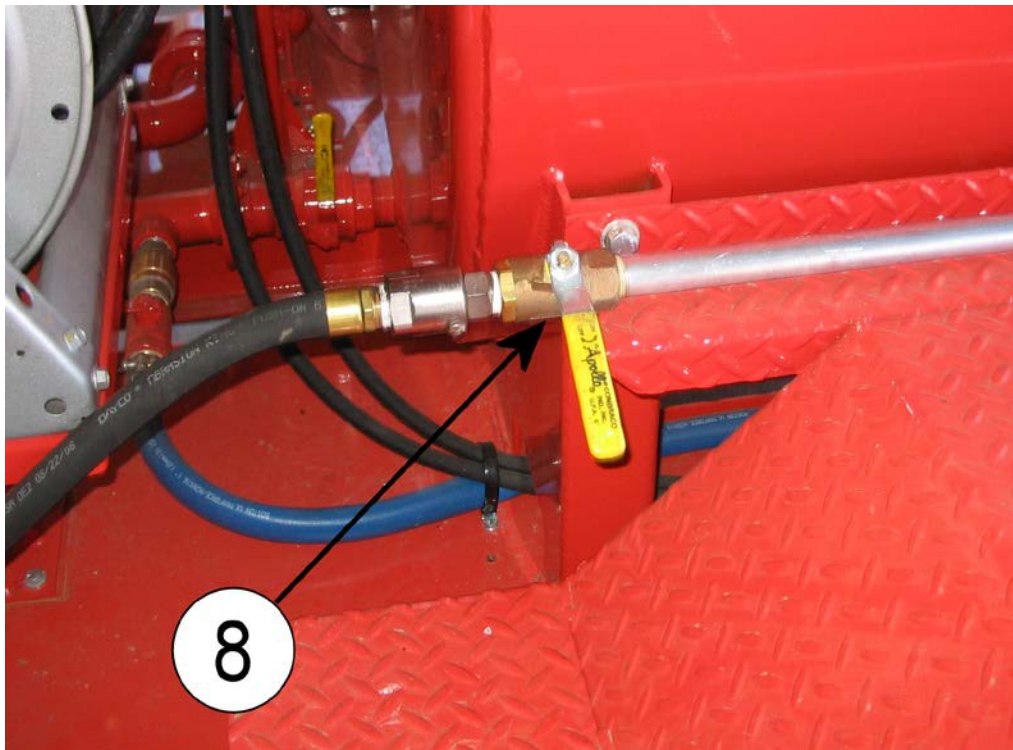


**Figure 5.2 Sealcoater Valves and Water Hose**

**Chapter 5 Operating Instructions**



**Figure 5.3 Air Compressor Valves**



**Figure 5.4 Material Valve #8**

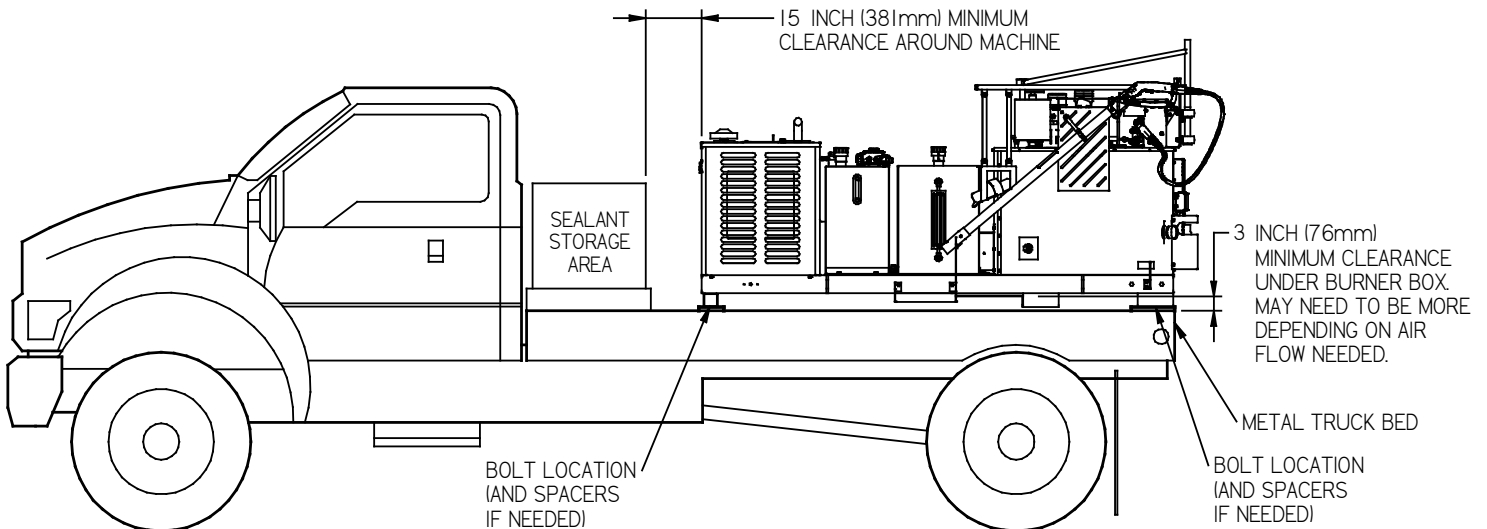
**Chapter 5 Operating Instructions**

**5.11 Mounting a Skid Machine**

**Table 5-13 Mounting a Skid Machine**

Step	Action
	<b>WARNING</b>
	The truck needs to be of proper size to hold the loaded weight and size of the machine and any extra material to be carried. The center of gravity of the loaded machine should be above or in front of the rear main axle. Contact CrafcO for help in determining the location of the center of gravity of your machine before mounting.
	<b>WARNING</b>
	Only mount the unit to a metal truck bed or any other non-flammable surface that can support the weight of the machine.
	<b>Failure to use the correct mounting surface could result in damage and possible fire!</b>
	<b>WARNING</b>
	Mount the machine a minimum of 3" (76mm) above the truck bed. Depending on the machine and airflow, you may have to mount it higher to prevent excessive temperatures on the machine and truck bed.
1	Mount with four ½" diameter Grade 5 bolts (or 12mm Grade 10.9) minimum, using the loading tubes at each corner of the machine to secure it in place.
	<b>WARNING</b>
	Leave 15" (381mm) clearance around the machine. Keep this area clear of any flammable material such as empty sealant boxes.
	<b>Failure to keep this area clear could result in damage and possible fire!</b>

**TYPICAL SKID MOUNT GUIDELINES**



## Chapter 5 Operating Instructions

### 5.12 Shutting Down the Machine

The steps for shutting down the machine vary based on being shut down only overnight, or being shut down for longer than 2 days.

#### 5.12.1 Shutting Down Overnight

**Table 5-14 Shutting Down Overnight**

Step	Action
1	Return the agitator control valve to the neutral position.
2	Turn the ignition key on the compressor unit to the off position.
3	Move the black gas lever on the compressor engine, located just below the grey choke lever to the off position. See <a href="#">Figure 5.1</a>
4	Drain the air from the compressor unit tank by opening air valve #12. See <a href="#">Figure 5.3</a>
5	Wind up the hand wand hose and lock hose reel.
6	Return hand wand to hand wand storage tab. Place the nozzle end of wand into drip tube.
7	Lock hand wand into storage tabs.
8	Return all equipment to storage deck and tie down.
9	Lock storage deck ramp in the up position.
10	Close all valves on the machine.

#### 5.12.2 Shutting Down Longer than 2 Days.

**Table 5-15 Shutting Down Longer than 2 Days**

Step	Action
1	Follow the material hose and hand wand cleanout procedure, See <a href="#">Table 5-9</a> .
2	Turn the ignition key on the compressor unit to the off position.
3	Move the black gas lever on the compressor engine to the off position, See <a href="#">Figure 5.1</a>
4	Drain the air from the compressor unit tank by opening air valve #12. See <a href="#">Figure 5.3</a>
5	Wind up the hand wand hose and lock hose reel.
6	Return hand wand to hand wand storage tab. Place the nozzle end of wand into drip tube.
7	Lock hand wand into storage tabs.
8	Return all equipment to storage deck and tie down.
9	Lock storage deck ramp in the up position.
10	Place all brooms and squeegees in brush box.
11	Close all valves on the machine.

## Chapter 6 Maintenance Instructions

### 6.0 Maintenance Instructions

This chapter contains all normal maintenance instructions to properly maintain your machine.

#### 6.1 Engine

Refer to the manufacturer's operating and maintenance instructions for the engine.

For an online PDF manual, visit <https://engines.honda.com/models/series/gx>.

#### 6.2 Hydraulic System

Check hydraulic fluid daily.

Change hydraulic filter every 250 hours of machine operation.

Change hydraulic fluid every 500 hours of operation.

#### 6.3 Material Pump 2"

Refer to separate manual in packet. For an online PDF manual, visit

<https://wildenstore.psgdover.com/products/aodd-pumps/item-08-14756-wilden-2inch-aluminum-proflo-shift/>.

#### 6.4 Water Pump 1/4"

Refer to separate manual in packet. For an online PDF manual, visit

<https://wildenstore.psgdover.com/products/aodd-pumps/item-00-9612-wilden-025inch-polypropylene-proflo/>.

#### 6.5 Lug Nuts

Torque all nuts/bolts before first road use and after each wheel removal. Check and torque after the first 10 miles, 25 miles, and again at 50 miles. Check periodically thereafter.

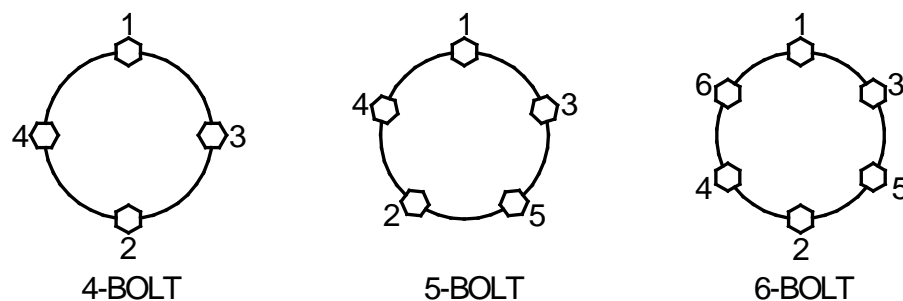
Torque in stages as follows:

First stage 20-25 foot-pound (ft-lb)

Second stage 50-60 foot pound (ft-lb)

Third stage 90-120 foot pound (ft-lb)

Tighten bolts and nuts in the sequence shown in [Figure 6.1 Lug Bolt Tightening Sequence](#).



**Figure 6.1 Lug Bolt Tightening Sequence**

**Chapter 6 Maintenance Instructions**

**6.6 Brakes**

Check the brakes daily.

**6.7 Tongue Jack**

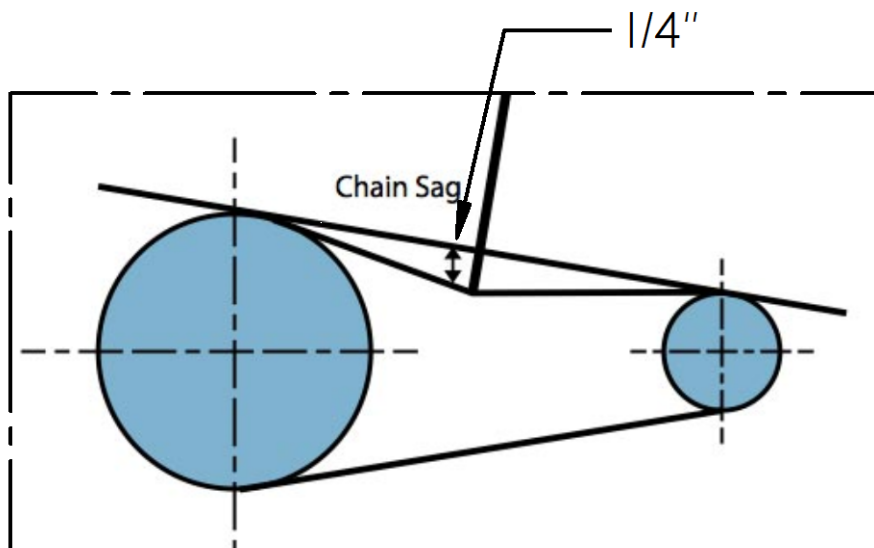
Lubricate the tongue jack, using a good grade of bearing grease.

**6.8 Agitator Drive Chain Tension**

Check the chain tension while doing hydraulic oil service every 250 hours of machine operation. The agitator drive chain should have 1/4" of deflection on the center of the chain. See [Figure 6.2 Agitator Drive Chain Tension](#). Follow the steps in [Table 6-1](#) to adjust the tension.

**Table 6-1 Agitator Drive Chain Tension Adjustment**

Step	Action
1	Loosen the 4 screws on the sides of the hydraulic motor adjustment bracket (See item 6 in <a href="#">Figure 8.11 Agitator Drive Chain</a> ).
2	Use two 3/8-16 jack screws in the top two holes of the bracket to adjust its position.
3	Measure the deflection in the chain halfway through its distance. See <a href="#">Figure 6.2</a> .
4	Once there is 1/4" of deflection, retighten the 4 mounting screws on the sides of the bracket, and remove the jack screws.



**Figure 6.2 Agitator Drive Chain Tension**

## Chapter 6 Maintenance Instructions

### 6.9 Cleaning the Sealcoater

We recommend using Orange-Sol industrial cleaner for cleaning the exterior of the machine. Here is the website for the cleaner; <https://www.orange-sol.com/industrial-formula/>.

### 6.10 Maintenance Chart

**Table 6-2 Maintenance Chart**

Part	Procedure	Hours			
		8	100	250	500
Engine Check Oil Level	Refer to the manufacturer's instructions for the engine	X			
Other Engine Maintenance	Refer to the manufacture's operating and maintenance instructions for the engine.				
Hydraulic Oil	Check	X			
	Change				X
Hydraulic Oil Filter	Change			X	
Agitator Drive Chain Tension	Check			X	
Wheel Bearings	Clean and re-pack using a good grade of bearing grease	Every 24,000 miles or two years			
Tongue Jack	Grease using a good grade of bearing grease	Once a year			
Material Tank	Scrape out built up material in the material tank	Once a year or as needed			

For a list of parts required for maintenance see [Table 6-4 General Maintenance Parts](#).

## Chapter 6 Maintenance Instructions

### 6.11 Service Instructions

**Table 6-3 Service Instructions**

Step	Action
1	Do a general inspection of the machine at least once a week.
2	Replace all worn or damaged parts. <b>Note:</b> Keep regular replacement items in stock for emergency repairs to prevent costly downtime. See <a href="#">Table 6-5 Recommended Spare Parts</a>
3	Make necessary adjustments and tighten all loose nuts or screws.
4	Watch for leaks. Tighten fittings or repair as necessary.
5	Clean the external surfaces of the machine at regular intervals.
6	Follow the recommended maintenance per <a href="#">Table 6-2 Maintenance Chart</a>

For service, find a list of authorized Distributors and service centers at [Crafco.com/Distributors](http://Crafco.com/Distributors).

### 6.12 General Maintenance Parts

**Table 6-4 General Maintenance Parts**

Quantity	Description	Part No.
1	Engine Air Filter	70325
1	Hydraulic Oil Filter	22071
<a href="#">Table 6-6</a>	Hydraulic Oil	<a href="#">Table 6-6</a>



## Chapter 6 Maintenance Instructions

### 6.13 Recommended Spare Parts

**Table 6-5 Recommended Spare Parts**

Quantity	Description	Part No.
3	Agitator Paddle wiper	70184
1-7	Spray Nozzles	70268
1	Strainer Basket Assembly	70225
1	Strainer Box Lid Gasket	70137
1	Hyd. Filter Element	22071

### 6.14 Recommended Fluids and Lubricants

**Table 6-6 Recommended Fluids and Lubricants**

Application	Recommended	Full Point
Engine Oil	Refer to engine manual	3 Qts. (2.8 L.)
Hydraulic Oil	Shell AW Hydraulic 46	6" (152mm) depth, approx. 5 Gals. (18.9 L)



## Chapter 7 How to Use a Multimeter

### 7.0 How to Use a Multimeter

Melters use 12-volt direct current (DC) to power the burner, hydraulic valves, and trigger on electric wand. The DC power is from a 12-volt battery.

The electric hose and wand uses 24-volt 3-phase alternating current (AC). The AC power is from the generator which hangs under the radiator. This system has no reference to ground so there is no possibility of electrical shock unless you are between 2 of the phases. **NOTE: ONLY CHECK AMPERAGE ON A HOSE WITH A CLAMP-ON AMP METER.** ( See [Figure 7.2 Clamp – On Amp Meter/Multimeter](#))

12-volt DC power has little danger of electrical shock. Care must still be taken when dealing with DC power systems because it is capable of producing large amounts of current.

### 7.1 Checking DC Voltage with a Multimeter

Connect the probes to the meter.

Set the range to a position that includes 12-volts or higher.

Touch the red probe to the positive side of accessory and black probe to ground. If the item you are checking has a ground wire attached then use that ground or you can use a non-painted surface on the frame.

### 7.2 Checking AC Voltage with Multimeter

Connect the probes to the meter (See [Figure 7.1 Standard Multimeter](#)).

Set the range to a position that includes 24-volts or higher.

There are three steps to test the generator voltage. All 3 values should be in the range of 24-30 volts AC.

- Touch red probe to the white wire of the generator and the black probe to the green wire of the generator.
- Next move black probe to black wire.
- Then move red probe to green wire.

### 7.3 Checking Resistance (Ohms)

Connect probes to the meter (See [Figure 7.1 Standard Multimeter](#)).

**Note:** When checking Ohms the circuit cannot be completed. This means one end of the wire will need to be disconnected.

#### 7.3.1 How to Check Wire Continuity

Set the meter to “Audible Continuity”.

Now touch the probe to each end of the wire in question. The meter will read “0” on the screen and make an audible beep if the wire has continuity from end to end.

#### 7.3.2 How to Check RTD Sensor

Set dial to Ohms  $\Omega$ . If your meter has different ranges set to 2K or 2000 ohm range.

Touch one probe to each screw or wire of the sensor. The meter will read X.XX if in the 2K range or XXX.X if in the 2000 range.

## Chapter 7 How to Use a Multimeter

### 7.4 Checking Amperage

The Multimeter can be used to check amperages under 10 amps in AC or DC current.

When checking the amperage of the electric hose **always use a clamp-on amp meter (See Figure 7.2 Clamp – On Amp Meter/Multimeter)**. The amperage in the hose can reach as high as 35 amps.

Clamp the meter around one wire at a time. Remember most clamp-on meters do not work on DC current.



Figure 7.1 Standard Multimeter

## Chapter 7 How to Use a Multimeter

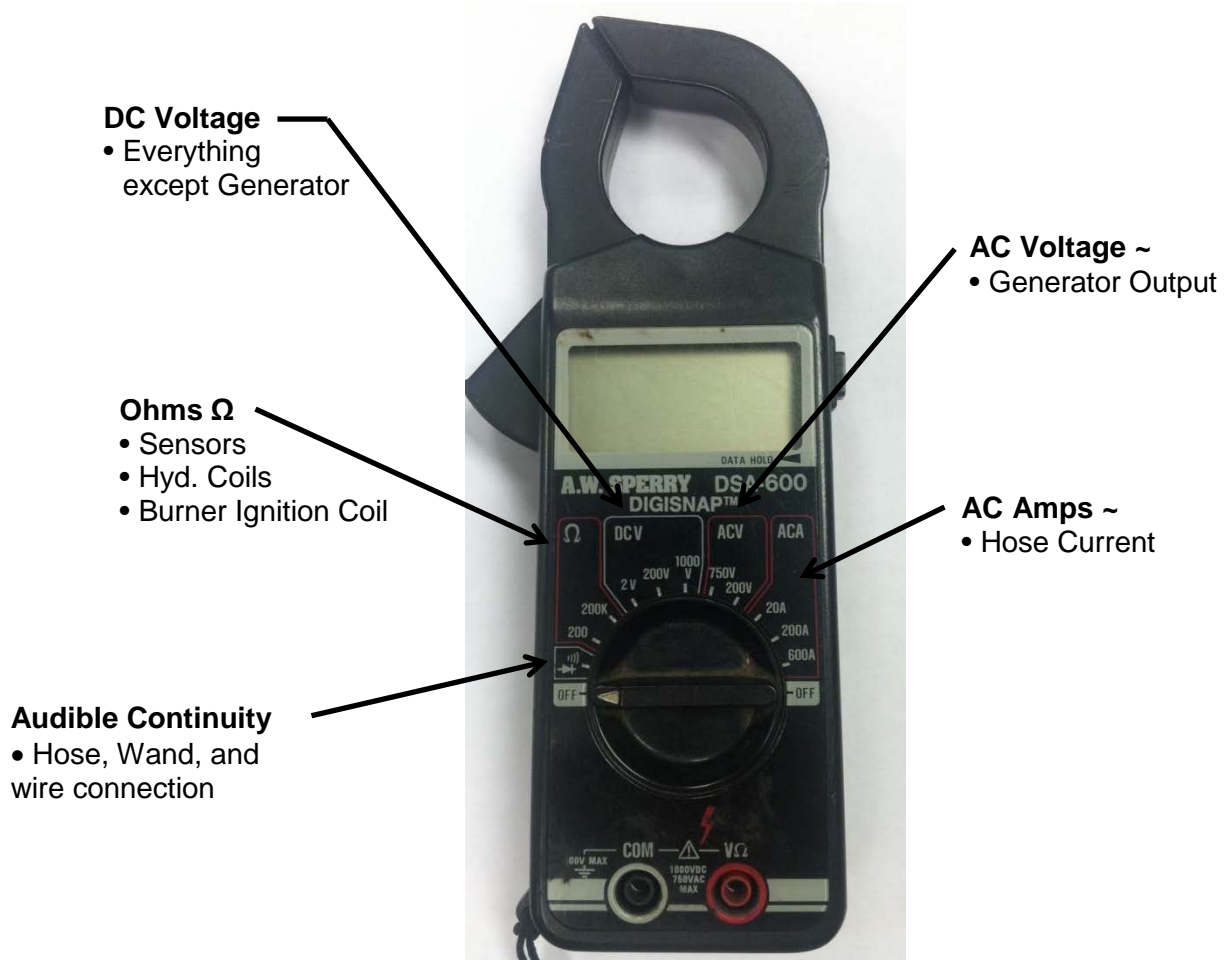


Figure 7.2 Clamp – On Amp Meter/Multimeter



## Chapter 8 Illustrated Parts List

### 8.0 About the Illustrated Parts List

The Illustrated Parts List (IPL) is designed to help technical service or maintenance personnel correctly identify orderable replacement parts.

Illustrations are designed to show general shape and size of a part and the relationship that part has to other parts. Actual size and shape of parts or components may differ or vary from the actual part or component.

### 8.1 Ordering Crafco Parts

Crafco distributors and Crafco Pavement Preservation Supply Centers are strategically located throughout the United States. Parts can be ordered from your local Crafco distributor or directly from Crafco, Inc. if a distributor is not available in your area.

When ordering parts, give the following information:

- Part Number
- Machine Model
- Serial Number

Write, call, or Fax Crafco, Inc. at the following:

Crafco, Inc. Headquarters

6165 W Detroit St.

Chandler, AZ 85226

Phone: (602) 276-0406

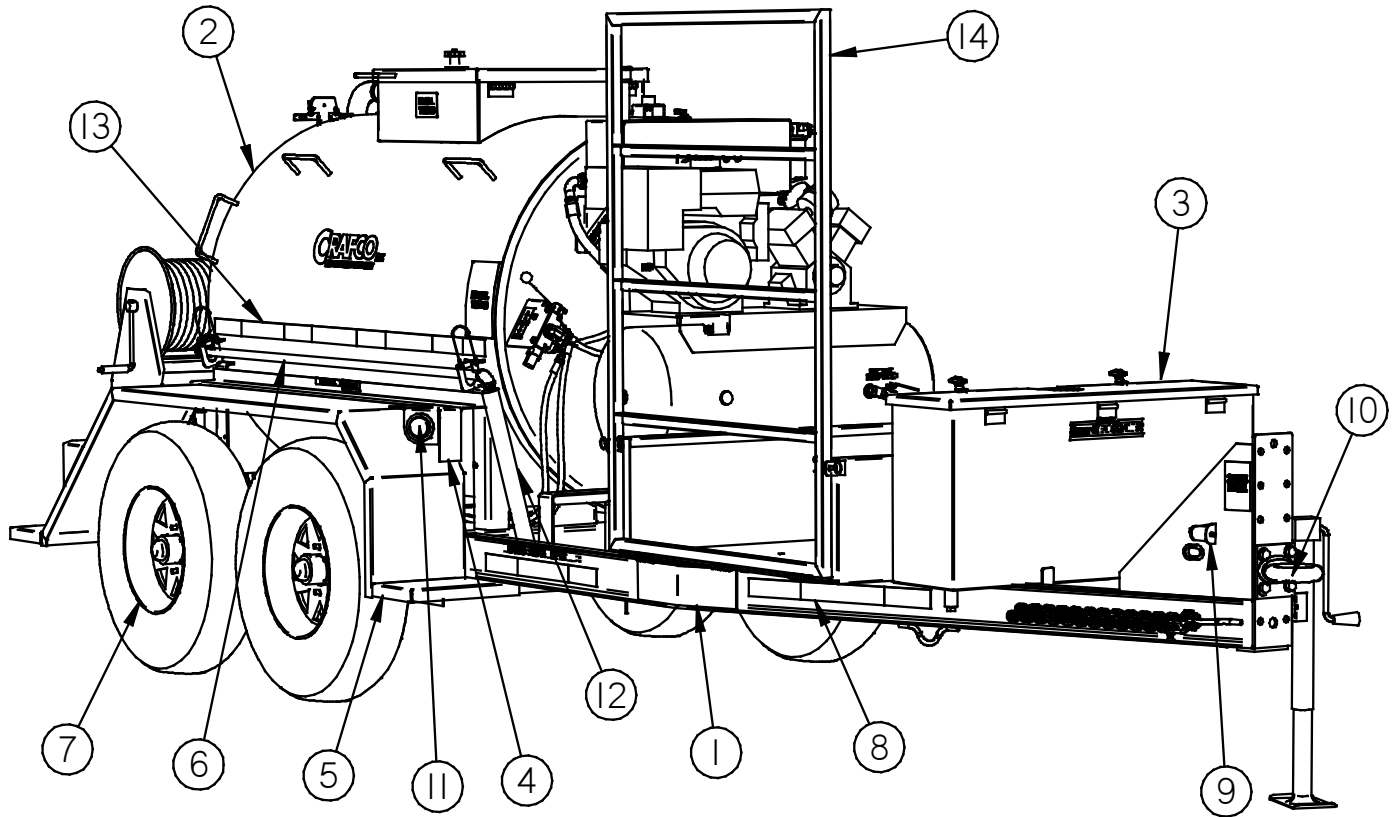
Toll Free: (800) 528-8242

Fax: (480) 961-0513

Visit our website at [www.crafco.com](http://www.crafco.com)

## Chapter 8 Illustrated Parts List

### 8.2 Super Sealcoater Passenger Side



**Figure 8.1 Super Sealcoater Passenger Side**



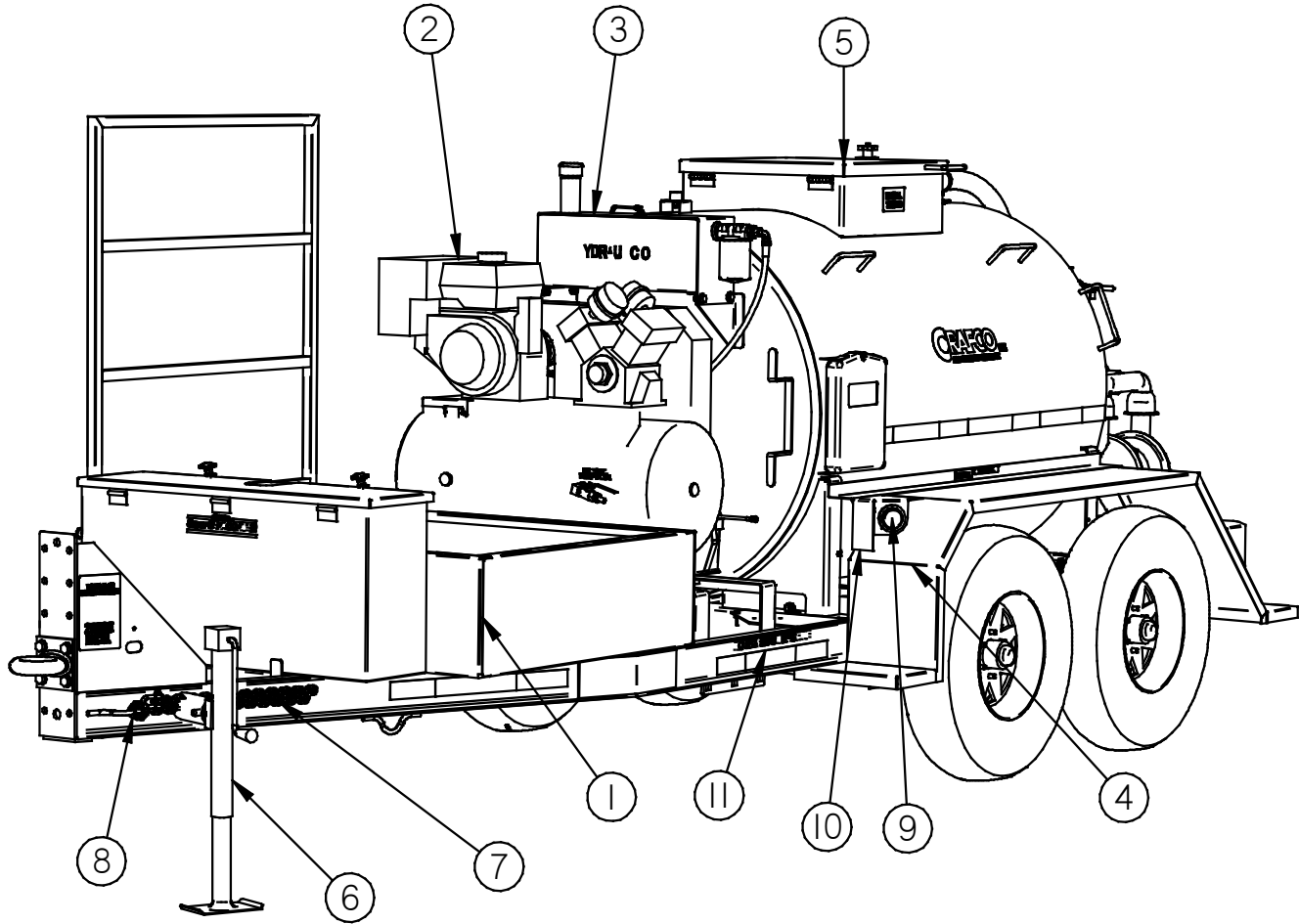
## Chapter 8 Illustrated Parts List

Table 8-1 Super Sealcoater Passenger Side

FIG.	ITEM	PART NO.	DESCRIPTION	QTY.
Figure 8.1	1	70005	SEALCOAT MACHINE TRAILER ASSEMBLY	1
	2	70025 70525	550 GAL SEALCOAT MACHINE TANK OR 800 GAL SEALCOAT MACHINE TANK	1
	3	70210	BRUSH BOX ASSEMBLY	1
	4	70086N	BRACKET, FRONT PASS SIDE LIGHT	1
	5	70075	FENDER ASSEMBLY – PASSENGERSIDE	1
	6	70248	HAND WAND ASSEMBLY COMPLETE	1
	7	70017	TIRE & RIM ASSEMBLY 550 GAL MACHINE	4
	7	70521	TIRE AND RIM ASSEMBLY 800 GAL MACHINE	4
	8	90539	TAPE, 2” REFLECTIVE – 24” LONG	1
	9	23117	BREAKAWAY SWITCH	1
	10	20014	HITCH 3” PINTLE ASSEMBLY	1
	11	44796	LIGHT, SIDE MARKER	2
	12	70255	HAND WAND DRIP TUBE	1
	13	90539	TAPE, 2” REFLECTIVE – 66” LONG	4
14	70090	STORAGE DECK RAMP ASSEMBLY	1	

## Chapter 8 Illustrated Parts List

### 8.3 Super Sealcoater Driver Side



**Figure 8.2 Super Sealcoater Driver Side**

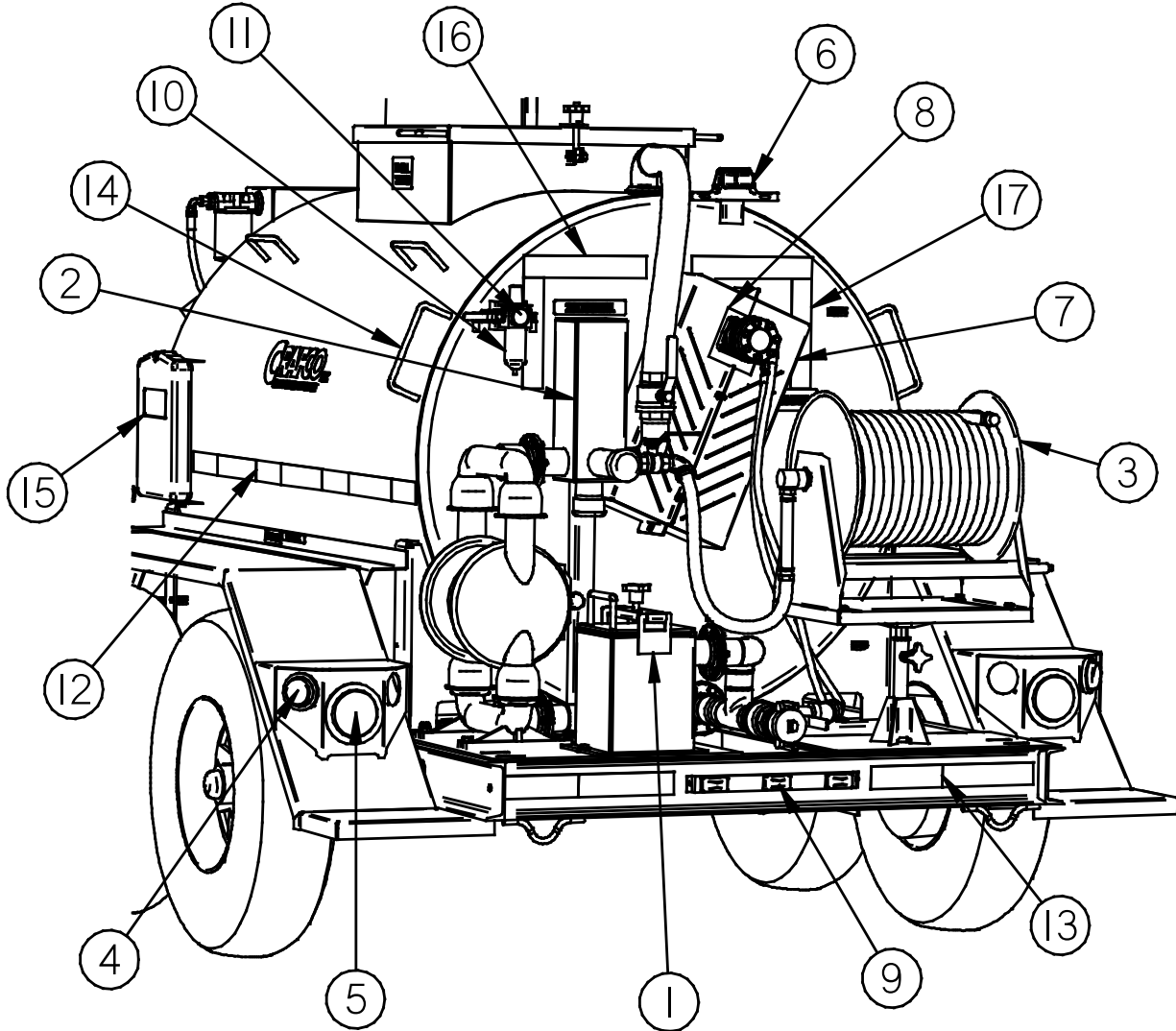
## Chapter 8 Illustrated Parts List

**Table 8-2 Super Sealcoater Driver Side**

FIG.	ITEM	PART NO.	DESCRIPTION	QTY.
Figure 8.2	1	70050	STORAGE DECK ASSEMBLY	1
	2	70308	AIR COMPRESSOR ASSEMBLY COMPLETE	1
	3	70100	HYD. OIL TANK ASSEMBLY	1
	4	70075	FENDER ASSEMBLY	2
	5	70140	MATERIAL HATCH LID ASSEMBLY	1
	6	23082	JACK, 5000#, 15" STROKE	1
	7	20130	CHAIN 3/8 PROOF COIL	2
	8	20132	SHACKLE, CHAIN CONNECTING LINK	2
	9	44796	2 1/2" LED YELLOW SIDE MARKER	2
	10	70087	LIGHT BRACKER, FRONT DRIVERS SIDE	1
	11	90539	TAPE, 2" REFLECTIVE – 24" LONG	4
	12	70315	OPTIONAL SPARE TIRE KIT 550 GAL. (NOT SHOWN)	1
	12	70381	OPTIONAL SPARE TIRE KIT 800 GAL (NOT SHOWN)	1

**Chapter 8 Illustrated Parts List**

**8.4 Super Sealcoater Rear**



**Figure 8.3 Super Sealcoater Rear**

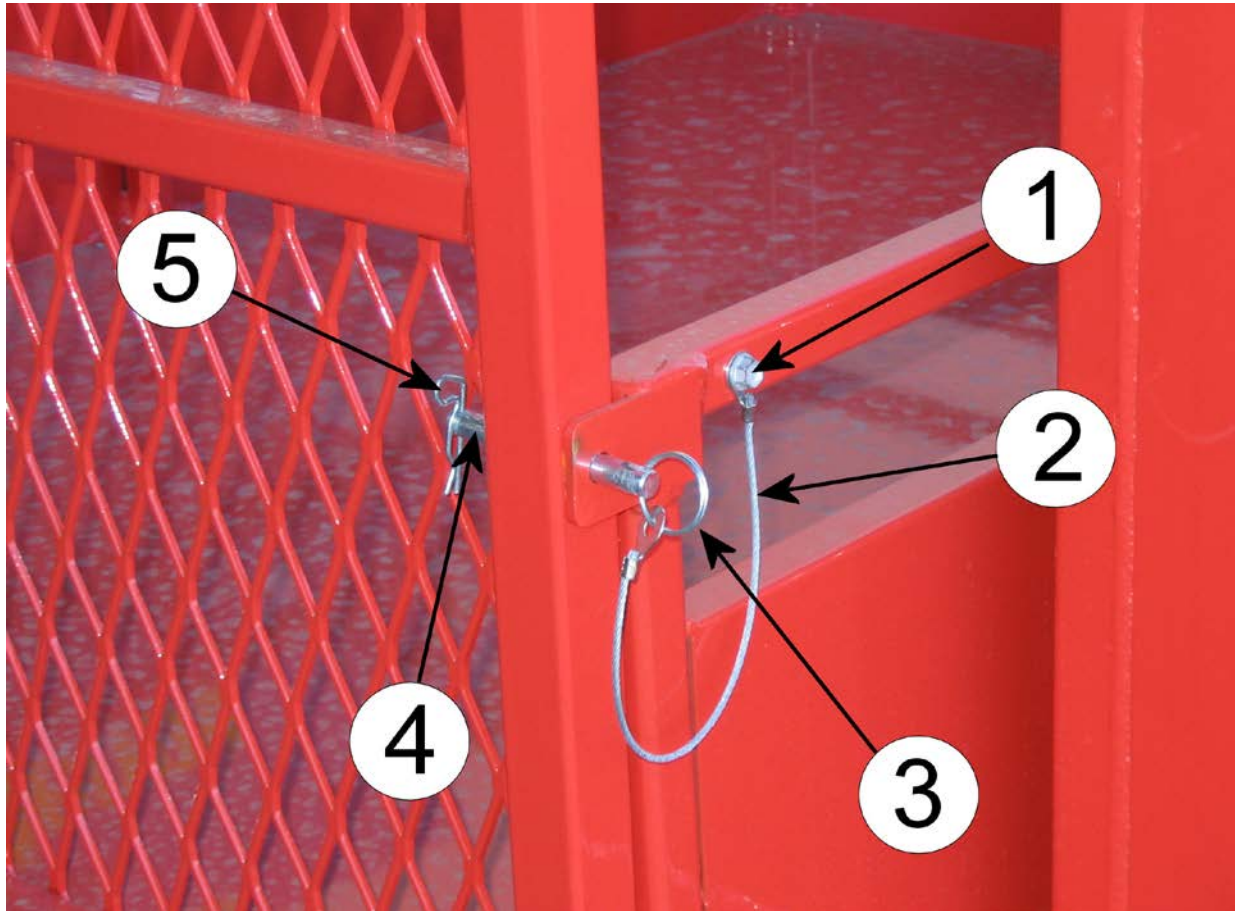
## Chapter 8 Illustrated Parts List

Table 8-3 Super Sealcoater Rear

FIG.	ITEM	PART NO.	DESCRIPTION	QTY.
Figure 8.3	1	70110	STRAINER BOX ASSEMBLY	1
	2	70125	EXPANSION TANK ASSEMBLY	1
	3	70206	MANUAL HOSE REEL	1
	4	44772	SIDE MARKER LIGHT	2
	5	70374	RECESSED TAIL-LIGHT LAMP	2
	6	90544	LICENSE PLATE BRACKET WITH LIGHT	1
	7	70257	AGITATOR SPROCKET BOTTOM GUARD	1
	8	70258	AGITATOR SPROCKET TOP GUARD	1
	9	24128	LIGHT, RED CLEARANCE	1
	10	70241	½" AIR REGULATOR & FILTER	1
	11	70242	AIR PRESSURE GUAGE – 0-160 P.S.I.	1
	12	90539	TAPE, 2" REFLECTIVE – 60" LONG	1
	13	90539	TAPE, 2" REFLECTIVE-16" LONG	2
	14	70037	MATERIAL TANK STEP HANDLE	6
	15	25289	RECORD BOX	1
	16	24042	TAPE, 2" WHITE REFLECTIVE – 10" LONG	2
	17	24042	TAPE, 2" WHITE REFLECTIVE – 12" LONG	2

**Chapter 8 Illustrated Parts List**

**8.5 Storage Deck Gate Lock**



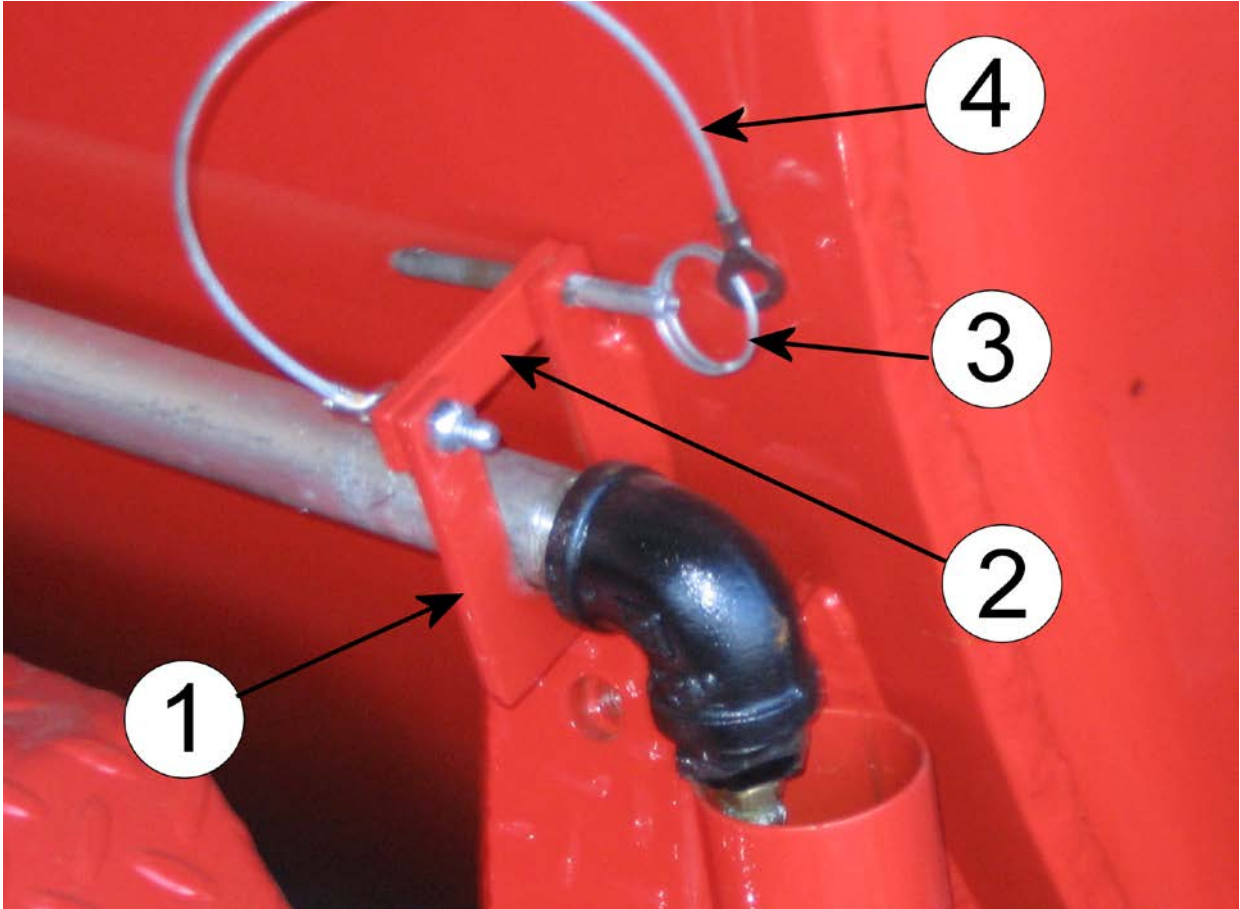
**Figure 8.4 Storage Deck Gate Lock**

**Table 8-4 Storage Deck Gate Lock**

FIG.	ITEM	PART NO.	DESCRIPTION	QTY.
Figure 8.4	1	28985	1/4" X 3/4" SELF TAP SCREW	1
	2	44157	PIN ATTACHMENT	4
	3	70068	SPLIT RING	2
	4	70060	3/8" DIA. CLEVIS PIN	2
	5	70067	HAIRPIN	1

**Chapter 8 Illustrated Parts List**

**8.6 Hand Wand Storage Tab**



**Figure 8.5 Hand Wand Storage Tab**

**Table 8-5 Hand Wand Storage Tab**

FIG.	ITEM	PART NO.	DESCRIPTION	QTY.
<b>Error! Reference source not found.</b>	1	70044	HAND WAND STORAGE TAB	1
	2	70045	HAND WAND STORAGE TAB CLAMP	1
	3	26104	¼" X 2 ½" QUICK PIN	1
	4	44157	PIN ATTACHMENT	4



## Super Sealcoater 550 & 800 Part Manual

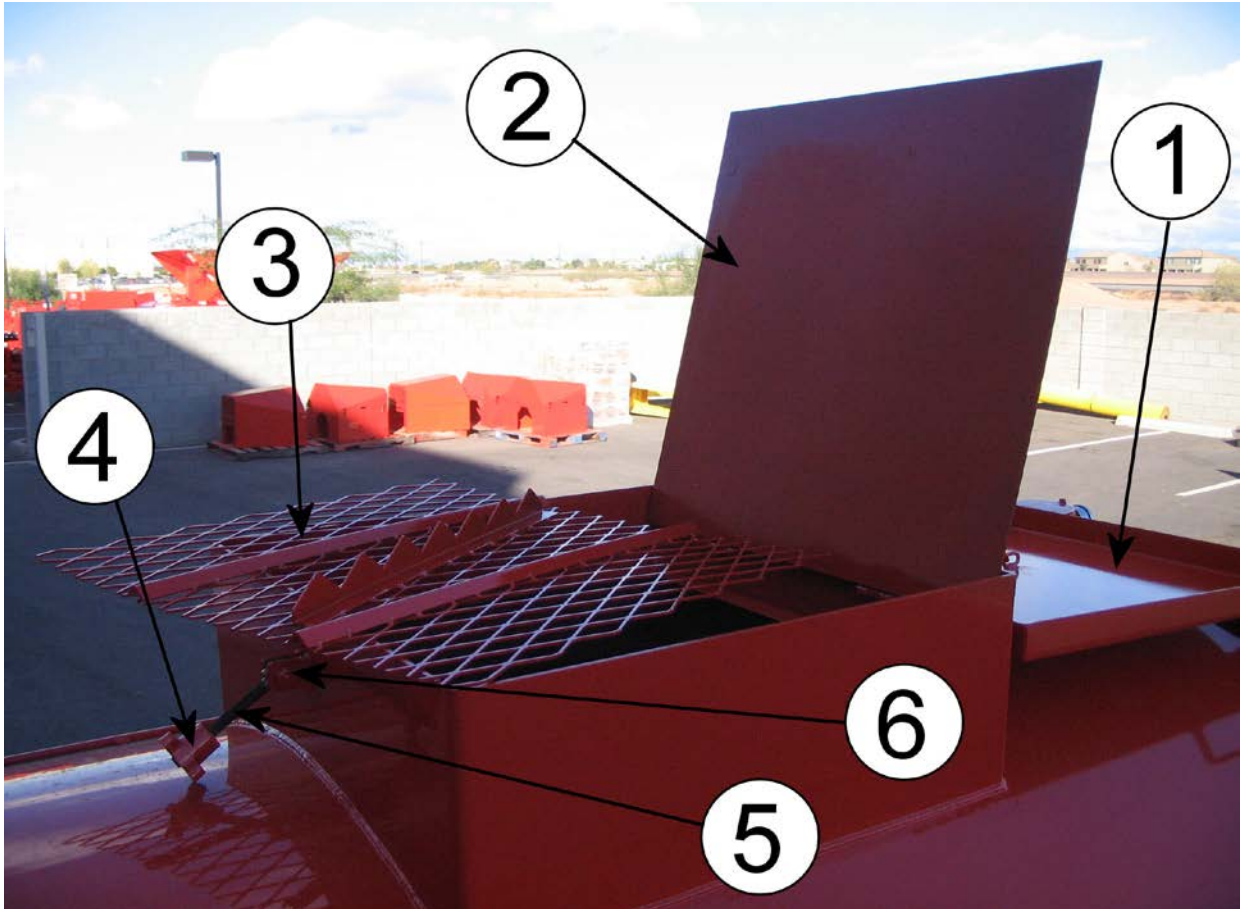
### Chapter 8 Illustrated Parts List

This page left blank intentionally



**Chapter 8 Illustrated Parts List**

**8.7 Material Tank Hatch**



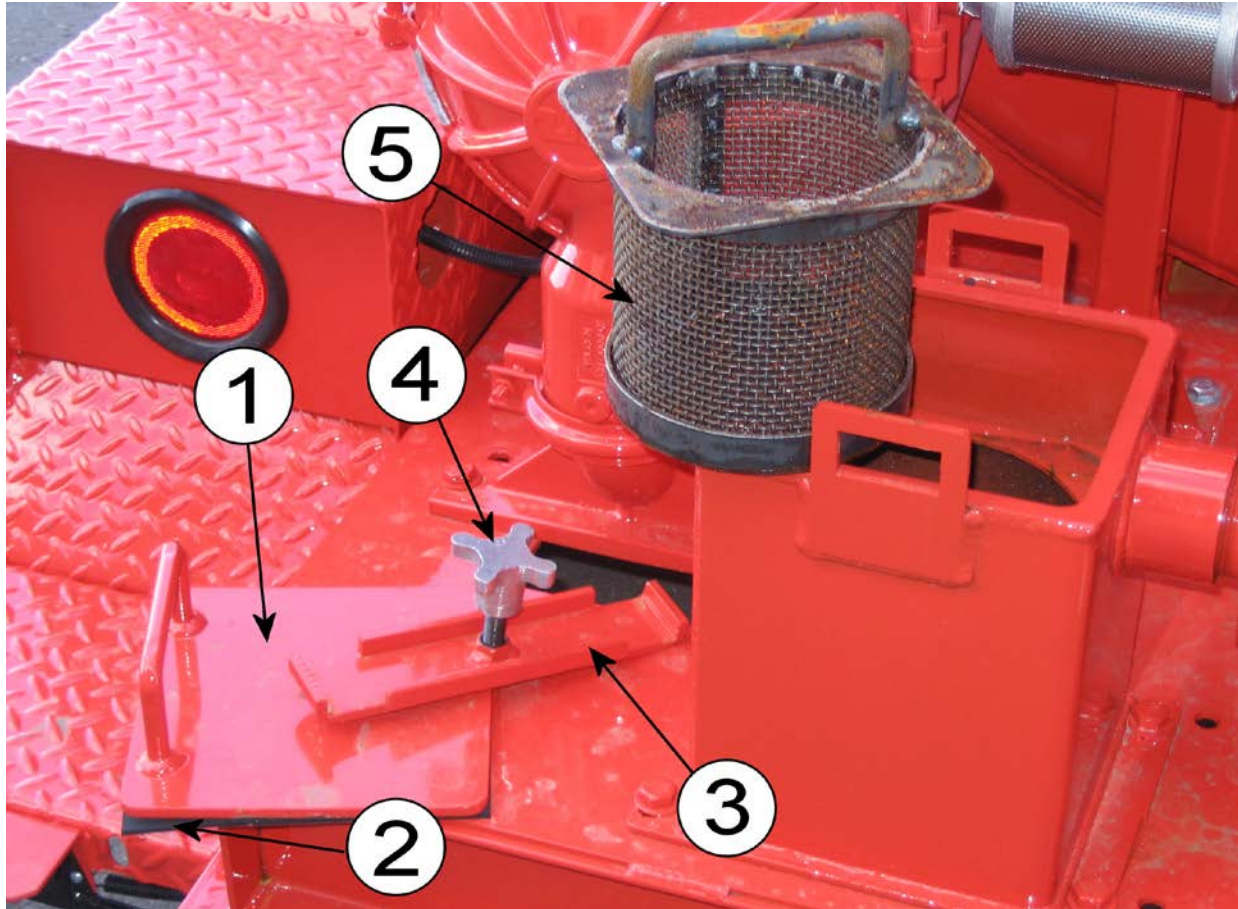
**Figure 8.6 Material Tank Hatch**

**Table 8-6 Material Tank Hatch**

FIG.	ITEM	PART NO.	DESCRIPTION	QTY.
Figure 8.6	1	70140	HATCH LID ASSEMBLY	1
	2	70142	SPLASH LID ASSEMBLY	1
	3	70144	SAND GRATING ASSEMBLY	1
	4	56816	CAST IRON KNOB	1
	5	56815	FEMALE THREADED ROD	1
	6	56814	PLATE LID PIVOT BRACKET	1

**Chapter 8 Illustrated Parts List**

**8.8 Strainer Box**



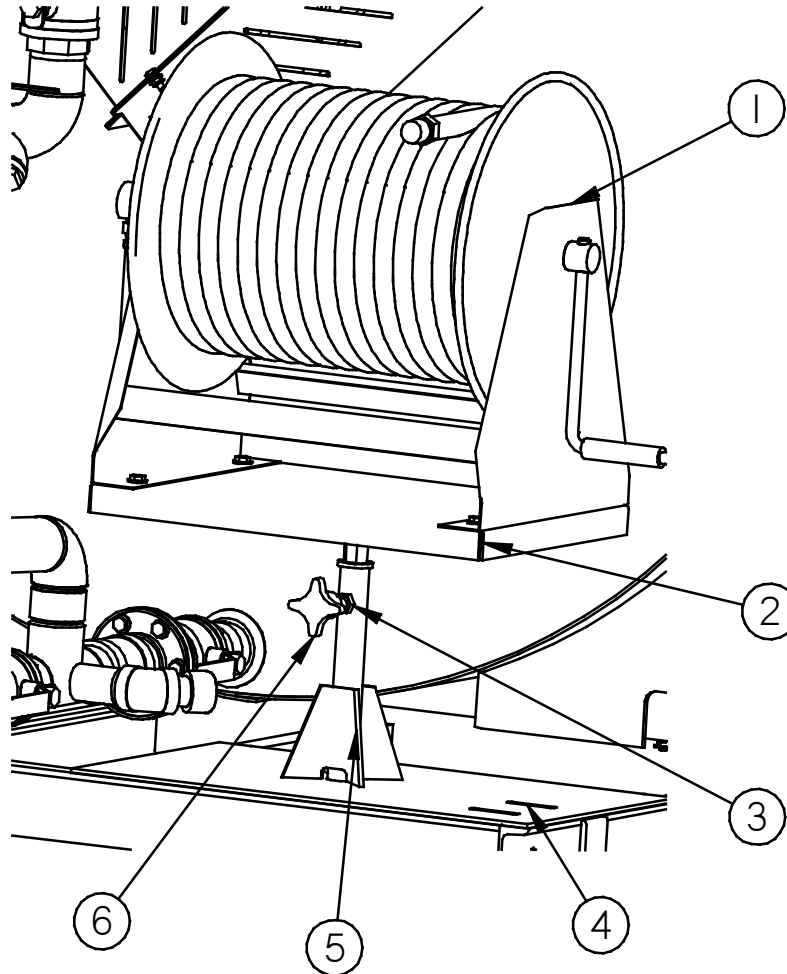
**Figure 8.7 Strainer Box**

**Table 8-7 Hydraulic Control Valve Assembly: PN 45420**

FIG.	ITEM	PART NO.	DESCRIPTION	QTY.
Figure 8.7	1	70117	STRAINER BOX LID ASSEMBLY	1
	2	70137	STRAINER BOX LID GASKET	1
	3	70120	STRAINER BOX LID STRAP ASSEMBLY	1
	4	70122	STRAINER BOX CLAMPING KNOB	1
	5	70225	STRAINER BASKET ASSEMBLY	1

**Chapter 8 Illustrated Parts List**

**8.9 Hose Reel Stand**



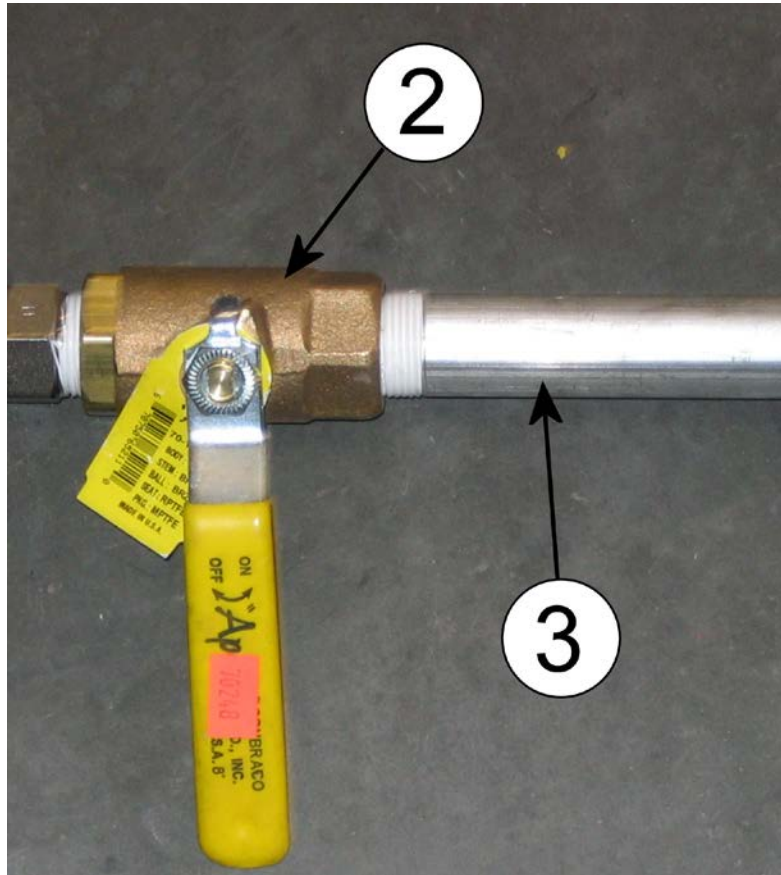
**Figure 8.8 Hose Reel Stand**

**Table 8-8 Hose Reel Stand**

FIG.	ITEM	PART NO.	DESCRIPTION	QTY.
Figure 8.8	1	70206	MANUAL HOSE REEL	1
	2	70200	HOSE REEL MOUNTING PLATE ASSEMBLY	1
	3	28504	1/2-13 HEX NUT	1
	4	70011	TRAILER PASSENGERSIDE REAR DECK PLATE	1
	5	70133	HOSE REEL STAND GUSSET	2
	6	70122	CLAMPING KNOB	1

**Chapter 8 Illustrated Parts List**

**8.10 Hand Wand Assembly**

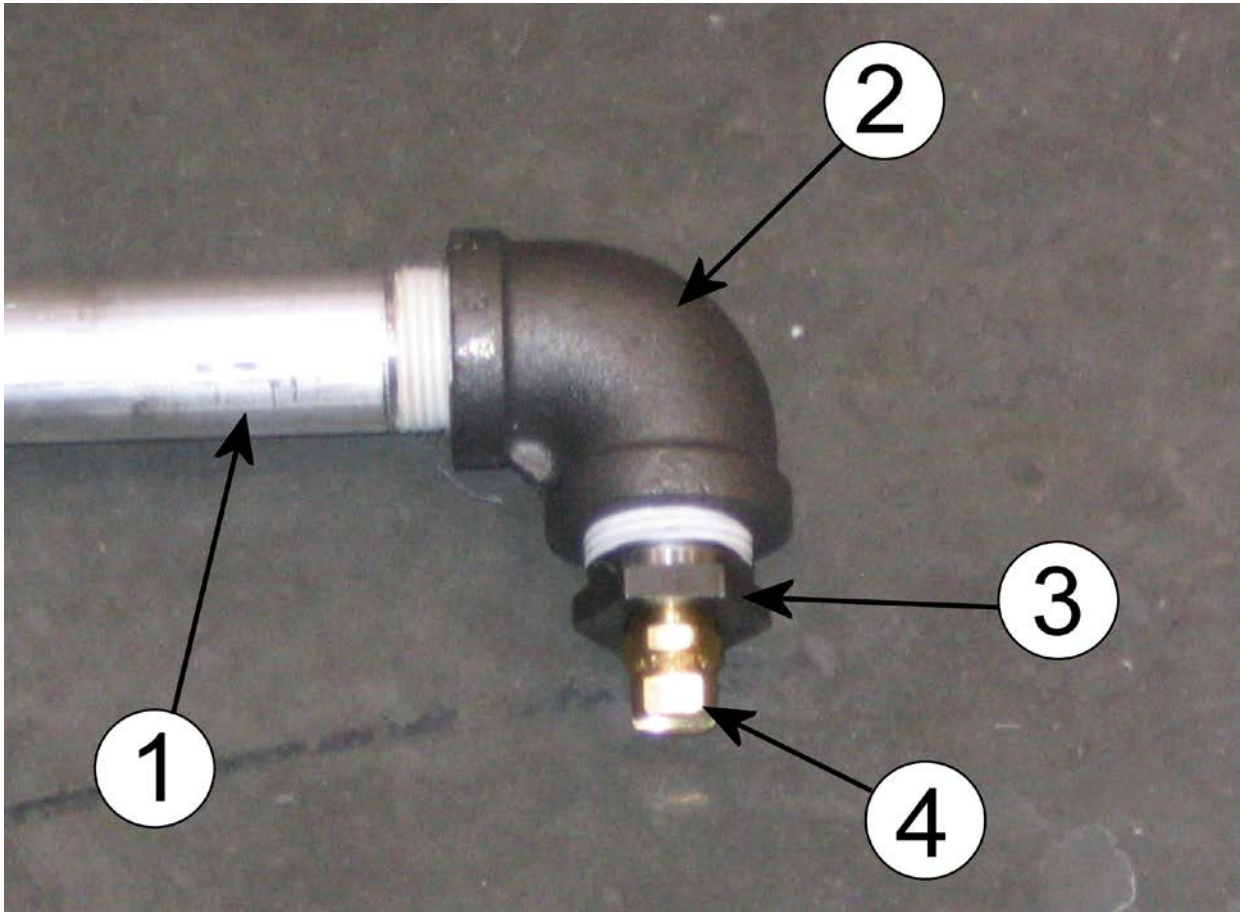


**Figure 8.9 Hand Wand Assembly Valve**

**Table 8-9 Hand Wand Assembly Valve**

FIG.	ITEM	PART NO.	DESCRIPTION	QTY.
Figure 8.9	2	29227	¾ BALL VALVE	1
	3	70249	HAND WAND BODY	1

**Chapter 8 Illustrated Parts List**



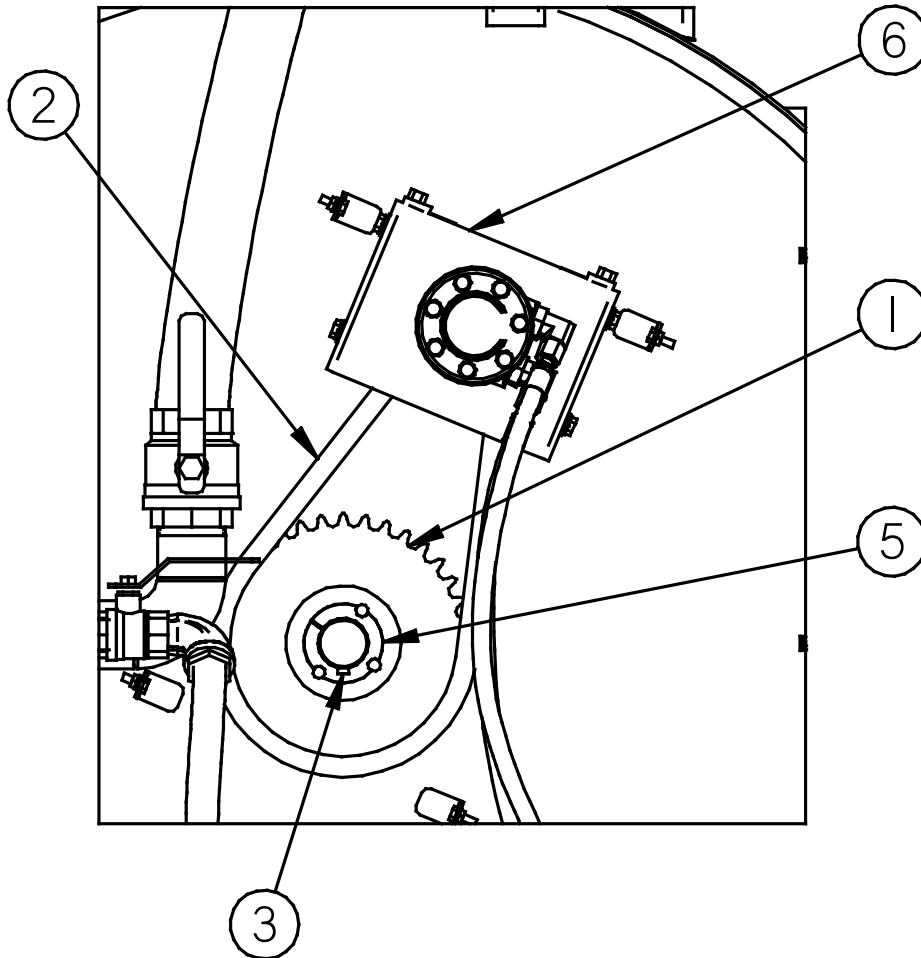
**Figure 8.10 Hand Wand Nozzle**

**Table 8-10 Hand Wand Nozzle**

FIG.	ITEM	PART NO.	DESCRIPTION	QTY.
Figure 8.10	1	70249	HAND WAND BODY	1
	2	28209	3/4" 90° PIPE ELBOW	1
	3	28346	BUSHING, 3/4" X 1/4"	1
	4	70268	FLAT SPRAY NOZZLE 80/50	1

**Chapter 8 Illustrated Parts List**

**8.11 Agitator Drive**

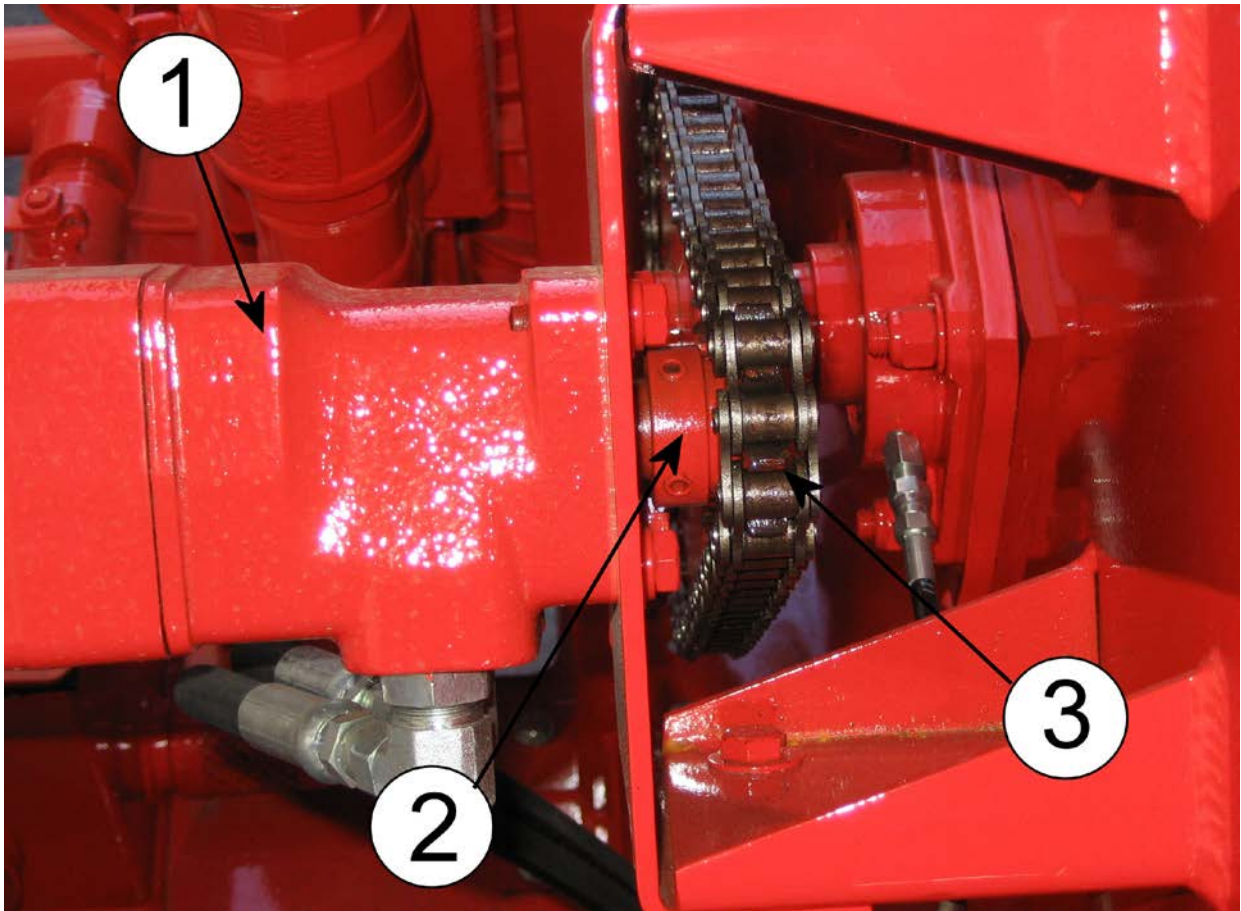


**Figure 8.11 Agitator Drive Chain**

**Table 8-11 Agitator Drive Chain**

FIG.	ITEM	PART NO.	DESCRIPTION	QTY.
Figure 8.11	1	70238	NO. 60 - 36 TOOTH SPROCKET	1
	2	70240	NO. 60 ROLLER CHAIN	1
	3	70233	AGITATOR SHAFT KEY	1
	4	70307	GREASE LINE (NOT SHOWN)	1
	5	70261	TAPER LOCK HUB	1
	6	70155	HYDRAULIC MOTOR ADJUSTMENT BRACKET	1

**Chapter 8 Illustrated Parts List**

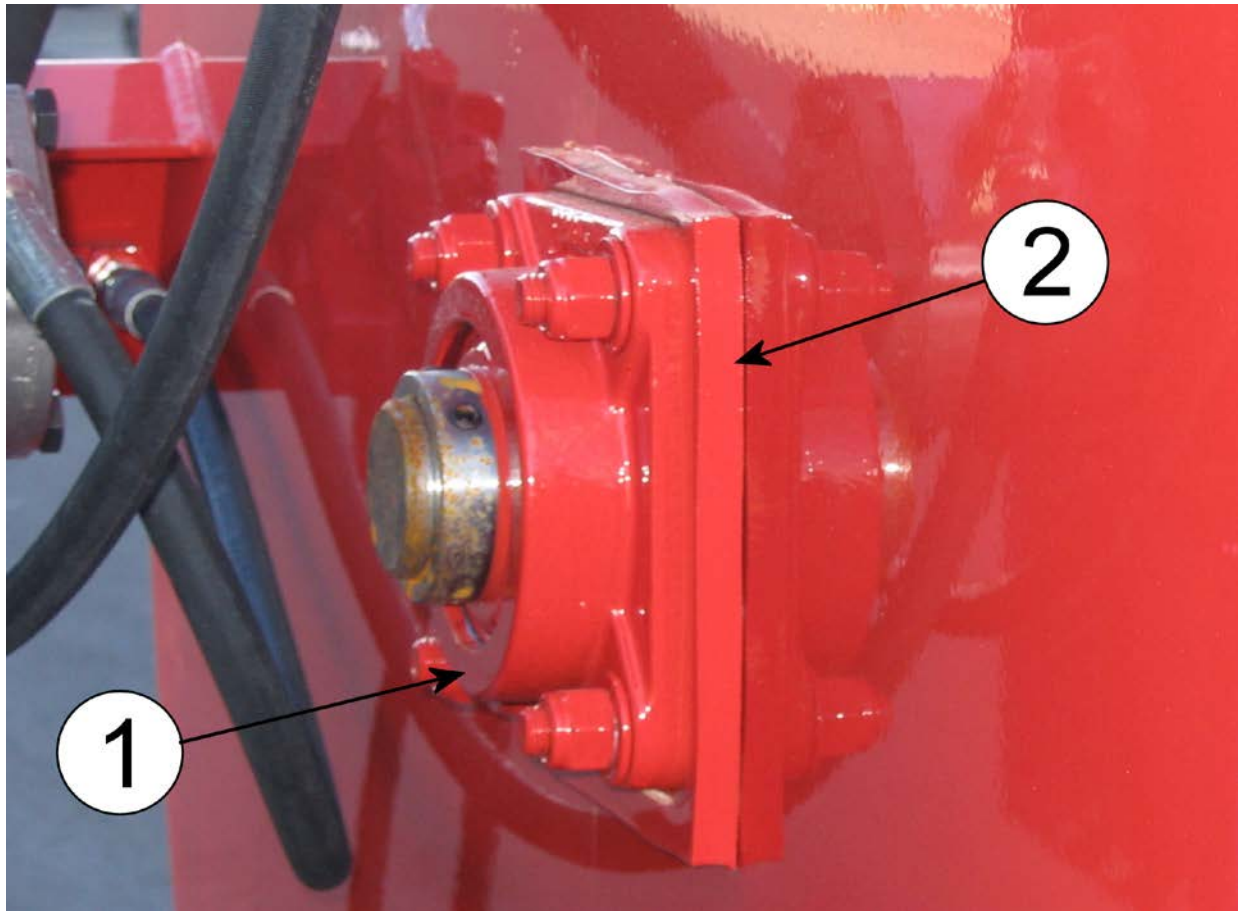


**Figure 8.12 Agitator Drive Motor**

**Table 8-12 Agitator Drive Motor**

FIG.	ITEM	PART NO.	DESCRIPTION	QTY.
Figure 8.12	1	45428	HYDRAULIC MOTOR	1
	2	70239	NO. 60 - 9 TOOTH SPROCKET	1
	3	70240	NO. 60 ROLLER CHAIN	1

**Chapter 8 Illustrated Parts List**



**Figure 8.13 Agitator Drive Bearing and Gasket**

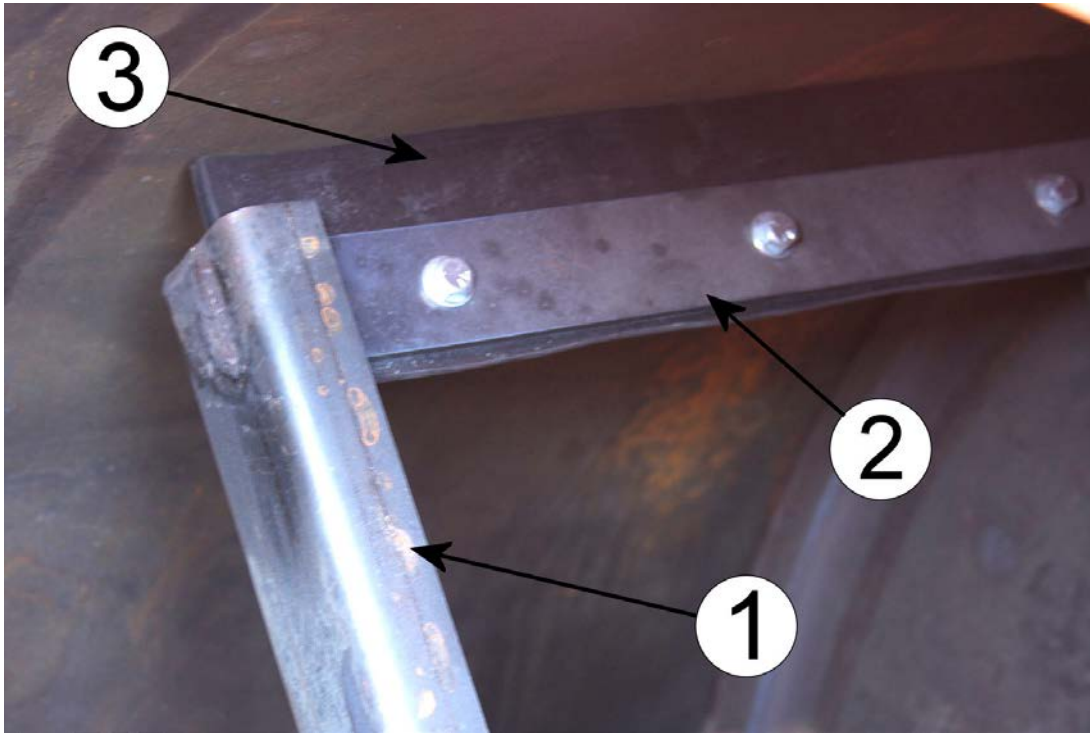
**Table 8-13 Agitator Drive Bearing and Gasket**

FIG.	ITEM	PART NO.	DESCRIPTION	QTY.
Figure 8.13	1	70237	1 3/4" FLANGE BEARING	2
	2	70234	AGITATOR BEARING GASKET	2



**Chapter 8 Illustrated Parts List**

**8.12 Agitator**



**Figure 8.14 Agitator Assembly**

**Table 8-14 Agitator Assembly**

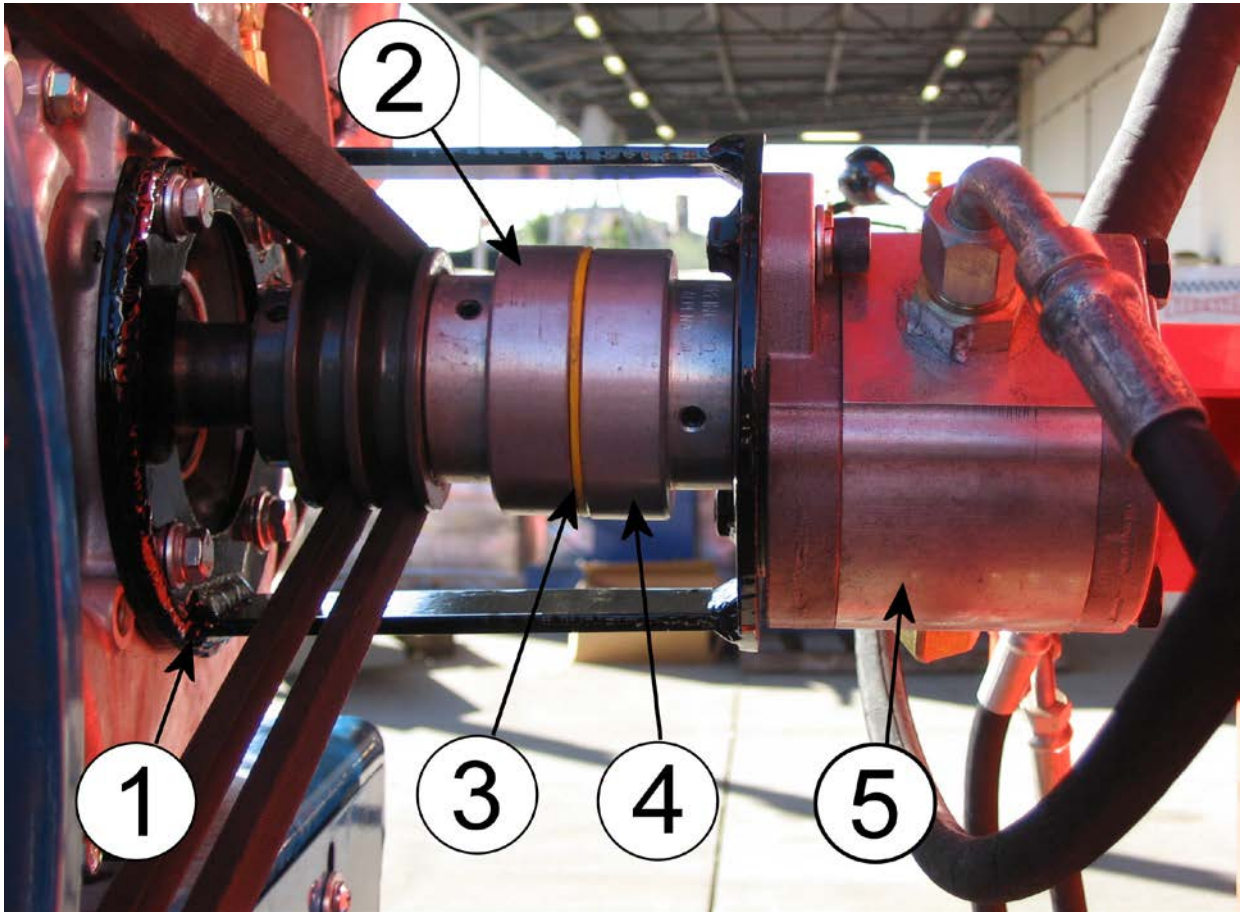
FIG.	ITEM	PART NO.	DESCRIPTION	QTY.
Figure 8.14	1	70179 (550 GAL) 70544 (800 GAL)	550 AGITATOR PADDLE ARM 800 AGITATOR PADDLE ARM	6
	2	70181 70183	AGITATOR CLAMP – OUTSIDE AGITATOR CLAMP - CENTER	3
	N/A	70180	AGITATOR PADDLE END (OPPOSITE AGITATOR CLAMP, NOT SHOWN)	3
	3	70184 70185	PADDLE WIPER – OUTSIDE PADDLE WIPER - CENTER	3
	N/A	70176	AGITATOR SHAFT	1

**Chapter 8 Illustrated Parts List**

This page left blank intentionally

**Chapter 8 Illustrated Parts List**

**8.13 Hydraulic Drive**



**Figure 8.15 Hydraulic Pump Without Cover**

**Table 8-15 Hydraulic Pump**

FIG.	ITEM	PART NO.	DESCRIPTION	QTY.
Figure 8.15	1	70215	HYDRAULIC PUMP MOUNTING BRACKET	1
	2	44829	COUPLING HALF, 1"	1
	3	44830	SPIDER COUPLING	1
	4	56303	COUPLING HALF, 5/8"	1
	5	70220	HYDRAULIC PUMP	1

## Chapter 8 Illustrated Parts List

### 8.14 Material System

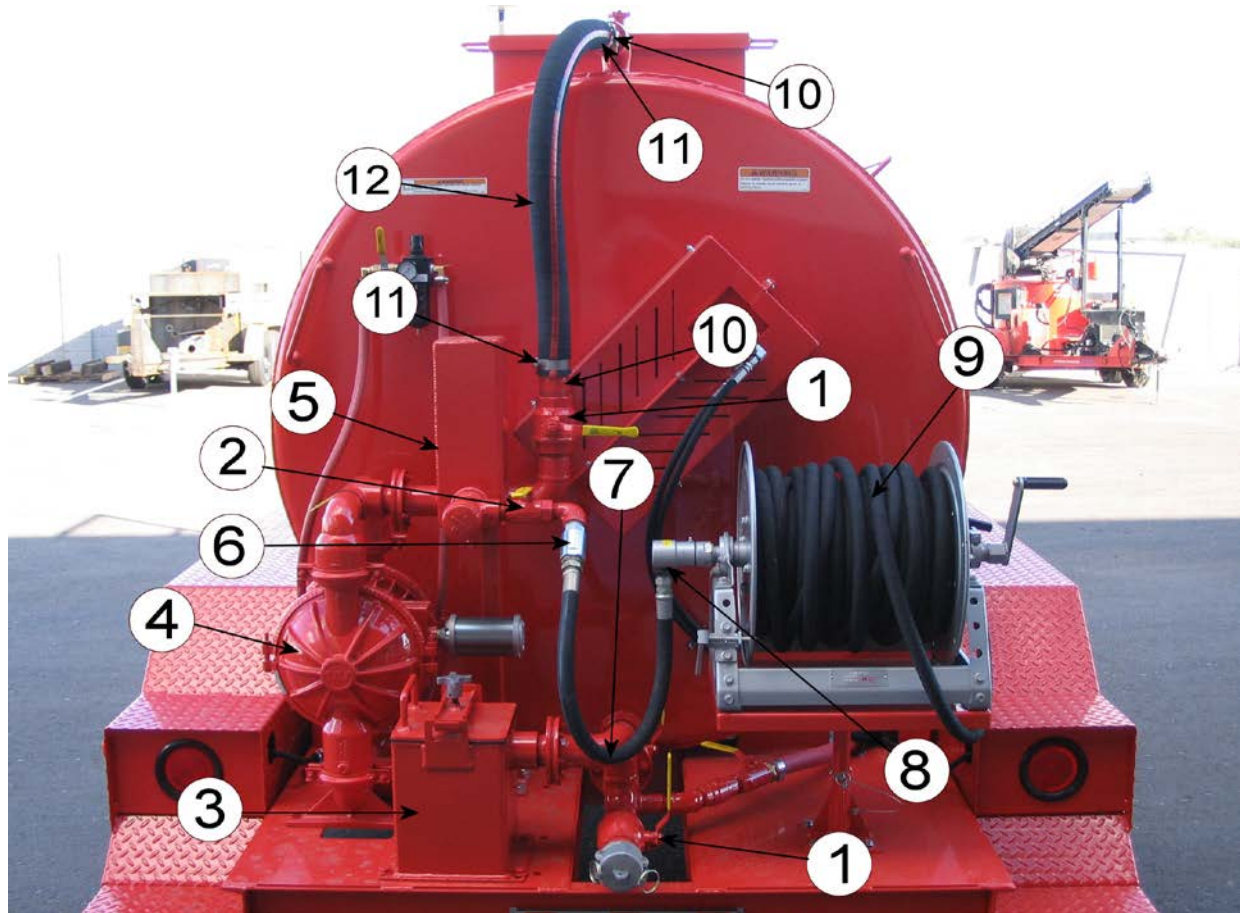


Figure 8.16 Material System

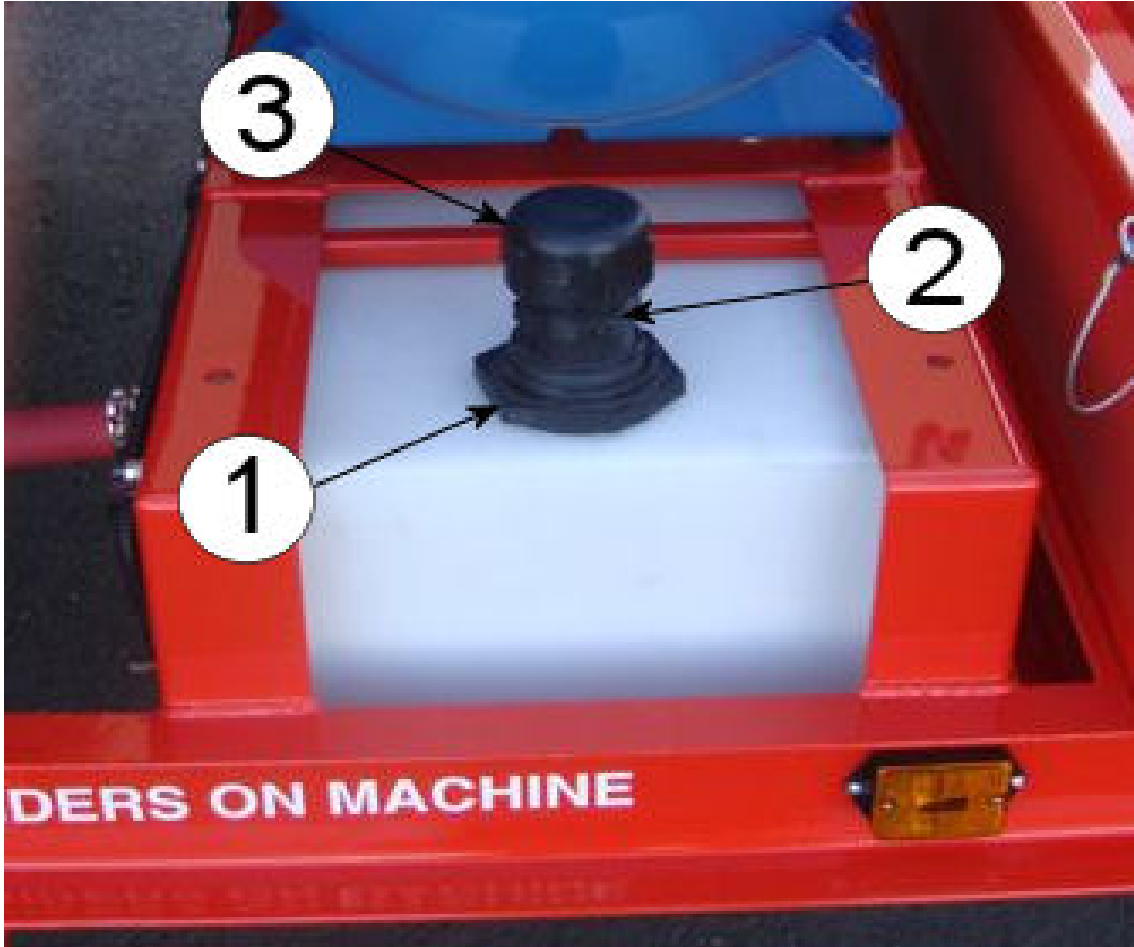
**Chapter 8 Illustrated Parts List**

**Table 8-16 Material System**

FIG.	ITEM	PART NO.	DESCRIPTION	QTY.
Figure 8.16	1	70327	2" BALL VALVE	2
	2	70221	1" BALL VALVE	1
	3	70110	STRAINER BOX ASSEMBLY	1
	4	70167	2" AIR DIAPHRAGM PUMP	1
	5	70125	EXPANSION TANK ASSEMBLY	11
	6	27048	1" INLINE SWIVEL	1
	7	70301	HOSE ASSEMBLY	1
	8	28351	1" X 3/4" HEX HEAD BUSHING	1
	9	70302	3/4" X 100' SLURRY HOSE	1
	10	70303	2" BARB FITTING	1
	11	70304	2" HOSE CLAMP	2
	12	70305	2" HOSE	2

**Chapter 8 Illustrated Parts List**

**8.15 Optional Water System**

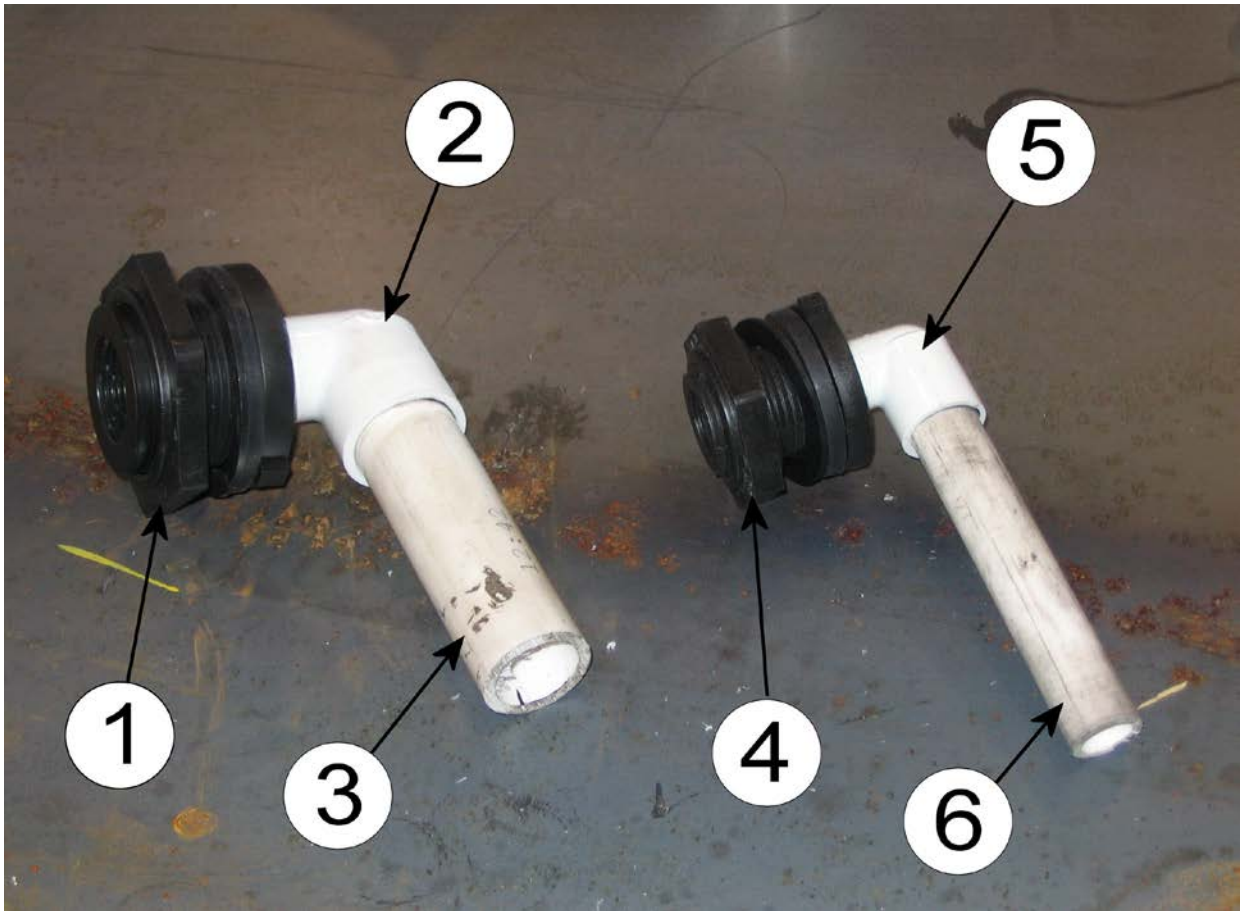


**Figure 8.17 Optional Water Tank**

**Table 8-17 Optional Water Tank**

FIG.	ITEM	PART NO.	DESCRIPTION	QTY.
Figure 8.17	1	70163	2" BULKHEAD FITTING	1
	2	70166	2" SCH. 40 X 2 ½" LONG PLASTIC PIPE NIPPLE	1
	3	70164	2" SCH. 80 PLASTIC PIPE CAP	1

**Chapter 8 Illustrated Parts List**

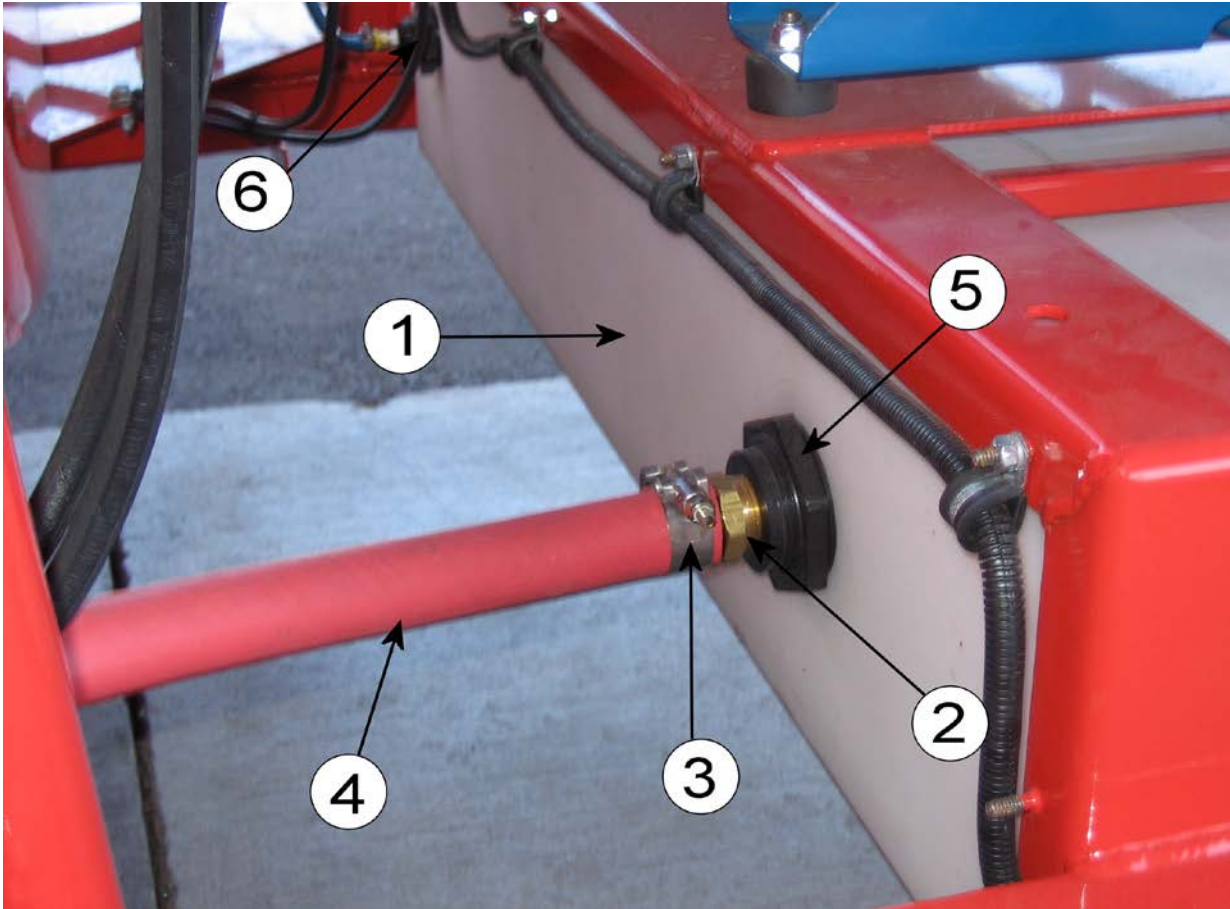


**Figure 8.18 Optional Water System Fittings**

**Table 8-18 Optional System Fittings**

FIG.	ITEM	PART NO.	DESCRIPTION	QTY.
Figure 8.18	1	70162	1" PLASTIC BULKHEAD FITTING	1
	2	70284	1" 90° PVC STREET ELBOW	1
	3	70282	1" SCH. 40 PVC PIPE X 6.5" LONG	1
	4	70161	1/2" PLASTIC BULKHEAD FITTING	1
	5	70285	1/2" 90° PVC STREET ELBOW	1
	6	70283	1/2" SCH. 40 PVC PIPE X 6.5" LONG	1

**Chapter 8 Illustrated Parts List**



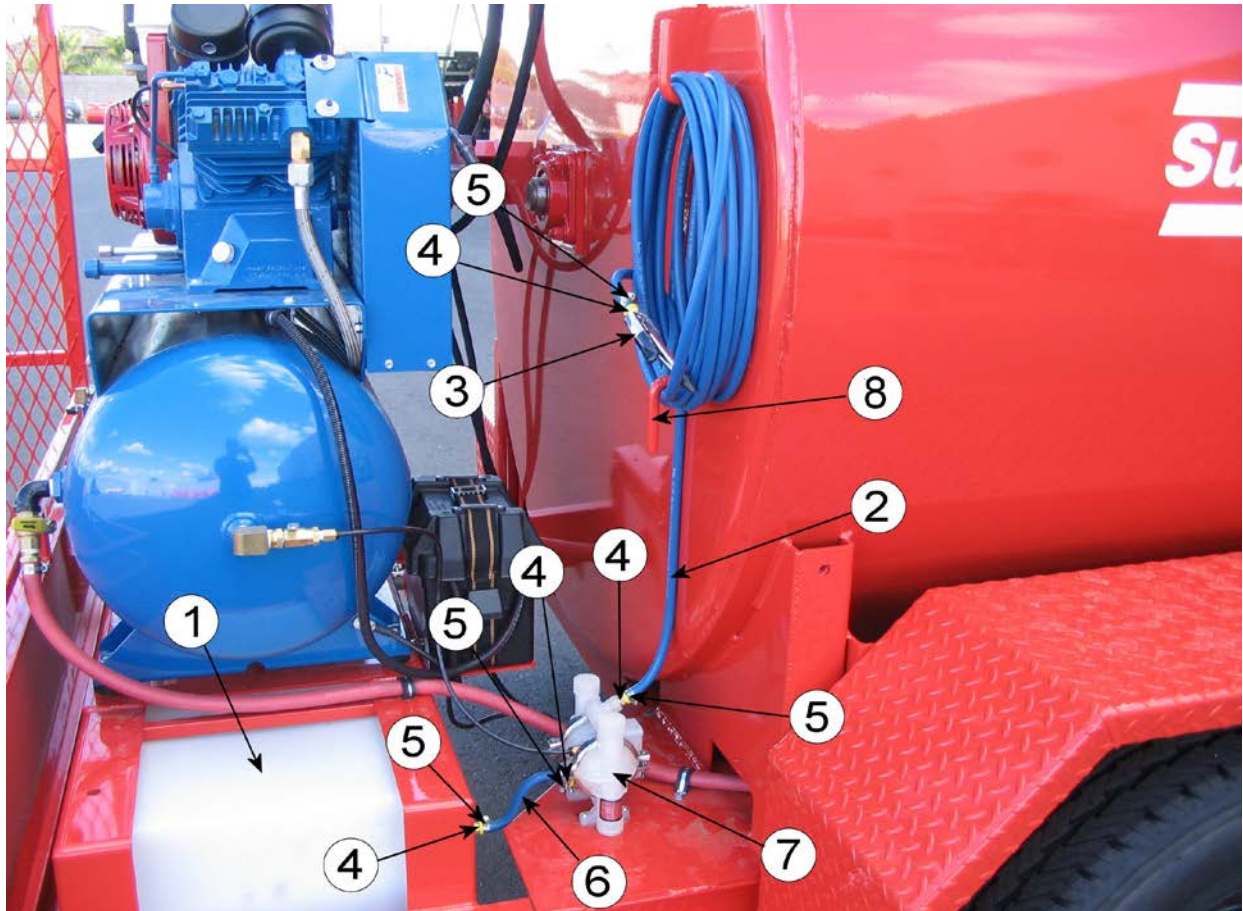
**Figure 8.19 Optional Water System**

**Table 8-19 Optional System**

FIG.	ITEM	PART NO.	DESCRIPTION	QTY.
Figure 8.19	1	70151	35 GAL PLASTIC WATER TANK	1
	2	70289	1" HOSE STRAIGHT MALE PUSH-ON FITTING	1
	3	70290	T-BOLT CLAMP – 1 1/2	1
	4	70291	1" PUSH-ON BLUE HOSE	1
	5	70162	1" PLASTIC BULKHEAD FITTING	1
	6	70161	½" PLASTIC BULKHEAD FITTING	1



**Chapter 8 Illustrated Parts List**

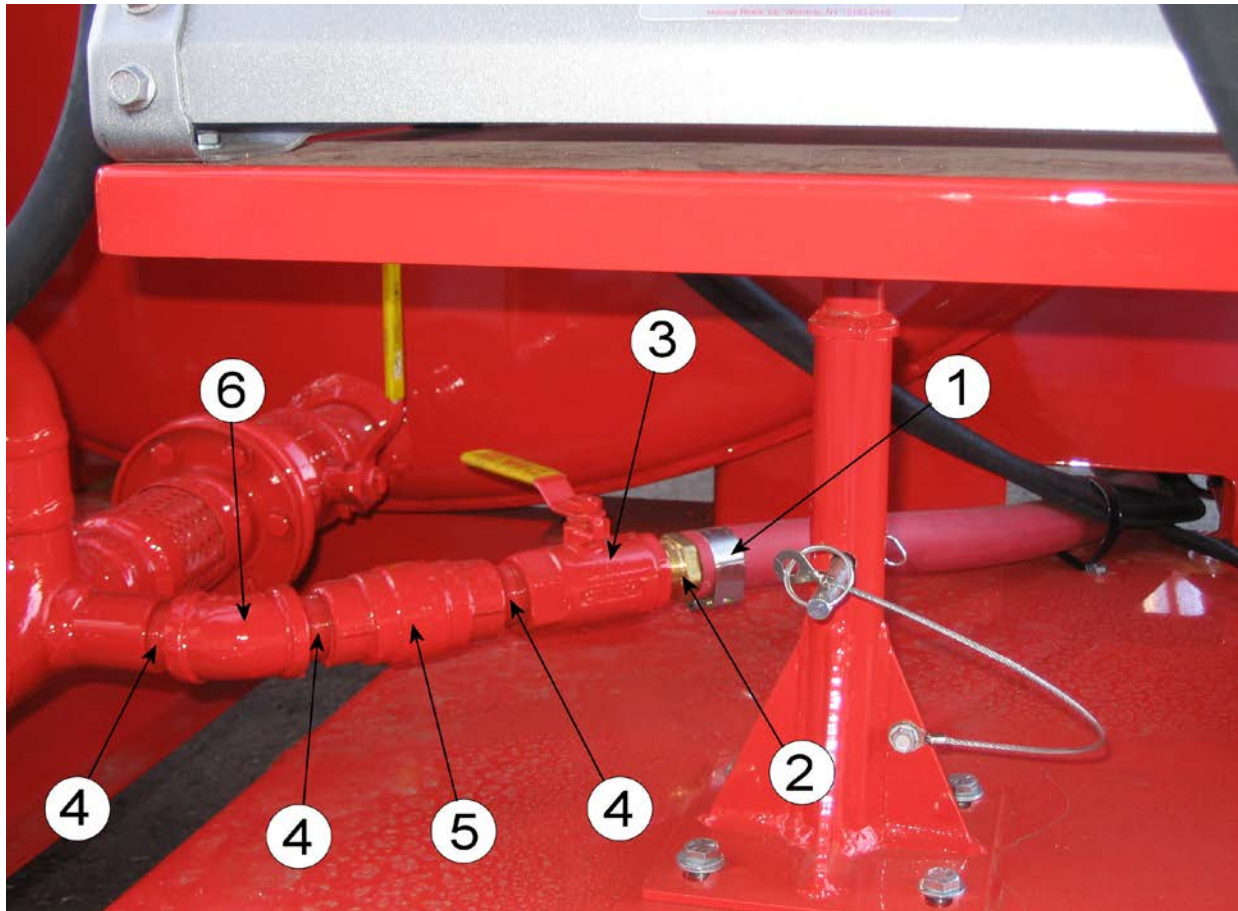


**Figure 8.20 Optional Water System (Continued)**

**Table 8-20 Optional Water System (Continued)**

FIG.	ITEM	PART NO.	DESCRIPTION	QTY.
Figure 8.20	1	70151	35 GAL PLASTIC WATER TANK	1
	2	70287	¼" PUSH-ON BLUE HOSE X 25'	1
	3	70288	RUBBER TIP BLOW GUN	1
	4	26751	¼" HOSE STRAIGHT MALE PUSH-ON FITTING	4
	5	26080	GEAR CLAMP SIZE #4	4
	6	70286	¼" PUSH-ON BLUE HOSE X 1'	1
	7	70173	0.25 AIR DIAPHRAGM PUMP	1
	8	91281	HOSE STROAGE BRACKET	1

**Chapter 8 Illustrated Parts List**



**Figure 8.21 Optional Water System Rear Valves**

**Table 8-21 Optional Water System Rear Valves**

FIG.	ITEM	PART NO.	DESCRIPTION	QTY.
Figure 8.21	1	70290	T-BOLT CLAMP, 1 1/2	1
	2	70289	1" HOSE STRAIGHT MALE PUSH-ON FITTING	1
	3	29236	1" BRONZE BALL VALVE	1
	4	28005	1" CLOSE NIPPLE	3
	5	70254	1" BRASS CHECK VALVE	1
	6	28195	1" 45° ELBOW	1



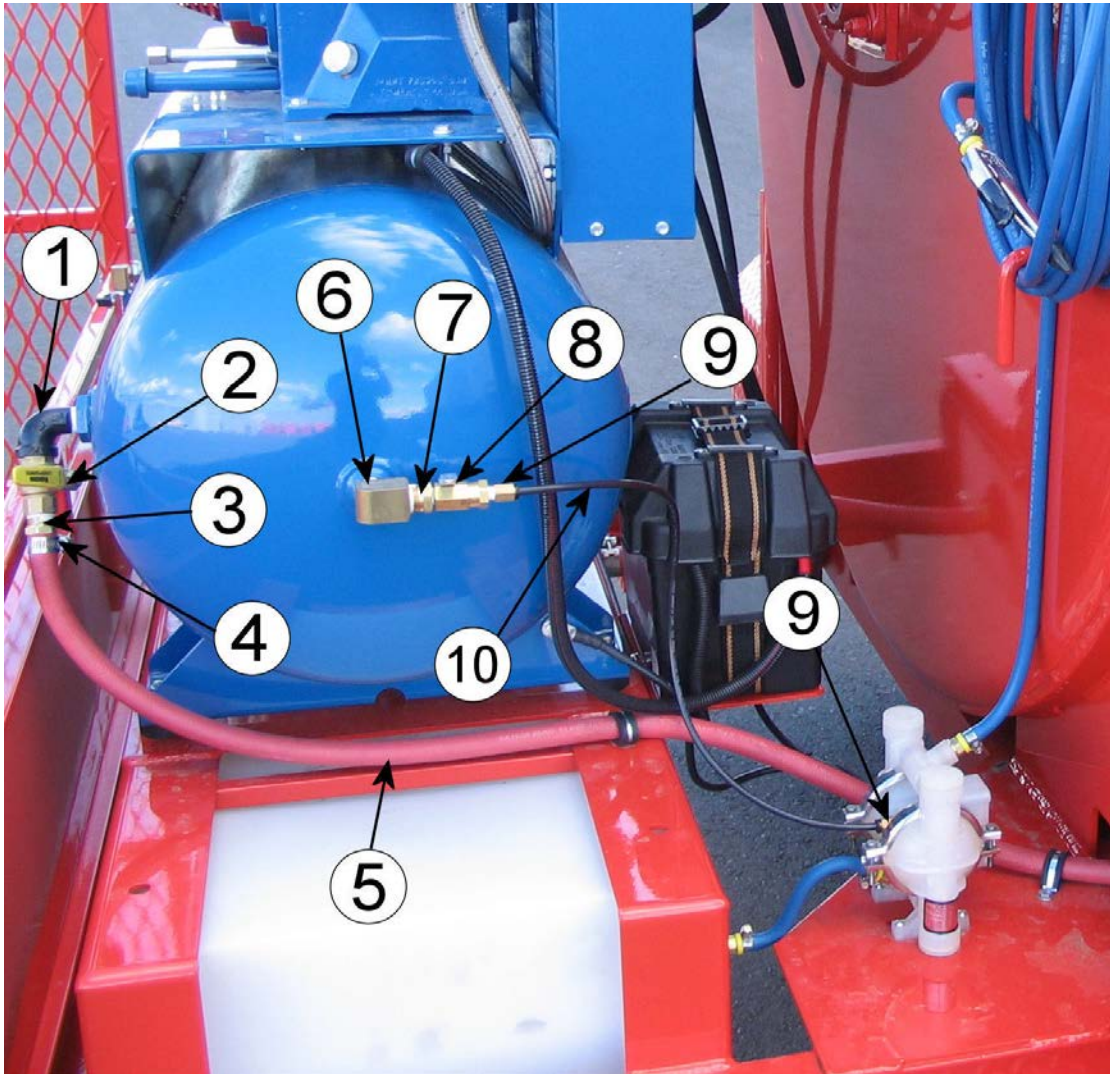
# Super Sealcoater 550 & 800 Part Manual

## Chapter 8 Illustrated Parts List

This page left blank intentionally

**Chapter 8 Illustrated Parts List**

**8.16 Air System**



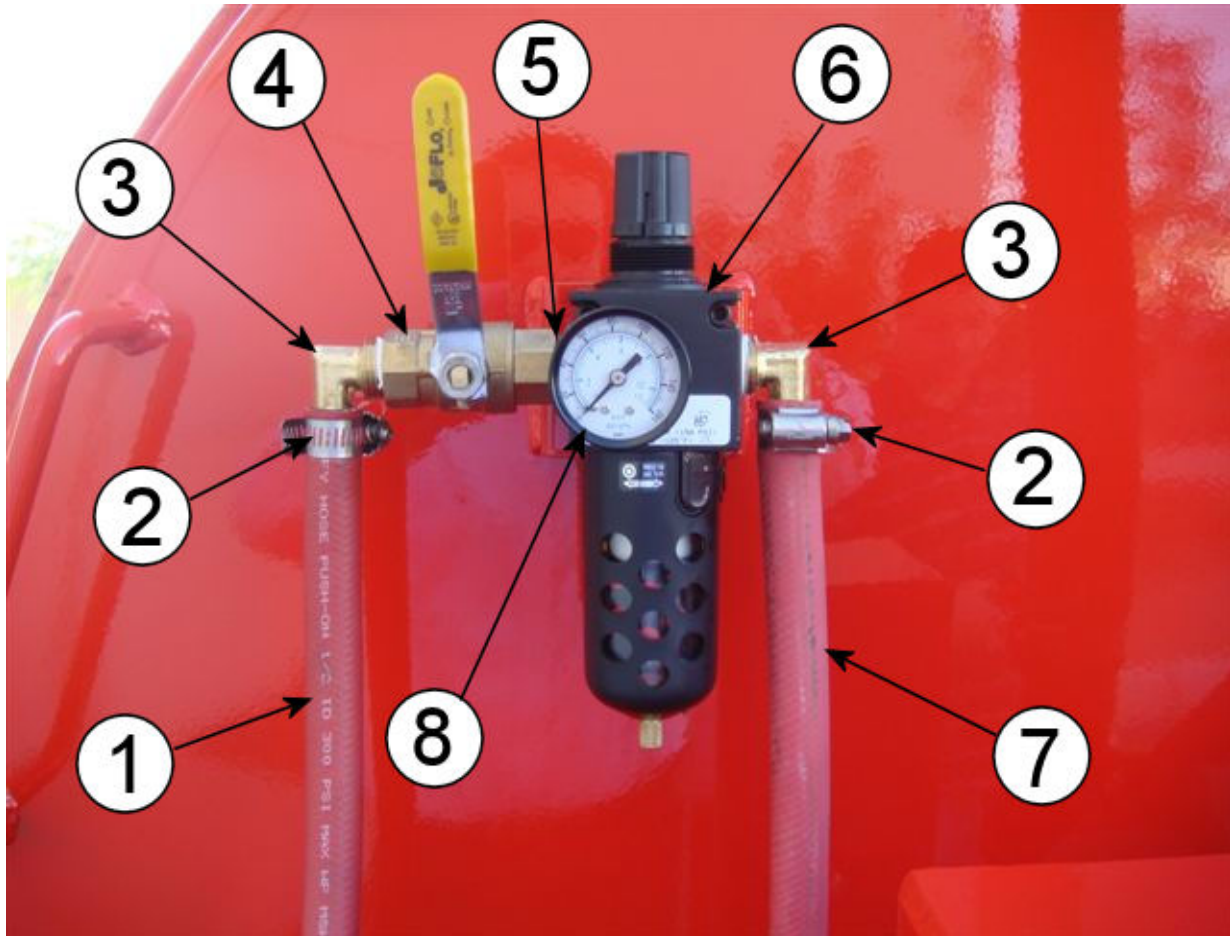
**Figure 8.22 Air System**

## Chapter 8 Illustrated Parts List

**Table 8-22 Air System**

FIG.	ITEM	PART NO.	DESCRIPTION	QTY.
Figure 8.22	1	28238	½" STREET ELBOW	1
	2	29214	½" BALL VALVE	1
	3	70292	BARB, ½ X ½ MPT	1
	4	70293	CLAMP, ½ X 29/32	1
	5	70294	HOSE, DUROFLEX ½ 300PS X 154" LONG	1
	6	70297	STREET 90, ½ BRASS (OPTIONAL)	1
	7	70321	½ X 1/8 HEX HEAD PIPE BUSHING (OPTIONAL)	1
	8	70298	BALL VALVE, 1/8 M X FPT (OPTIONAL)	1
	9	70299	AB FITTING, ¼ X 1/8 MPT (OPTIONAL)	2
	10	90897	TUBING, ¼ NYLON AB X 2' LONG (OPTIONAL)	1

**Chapter 8 Illustrated Parts List**

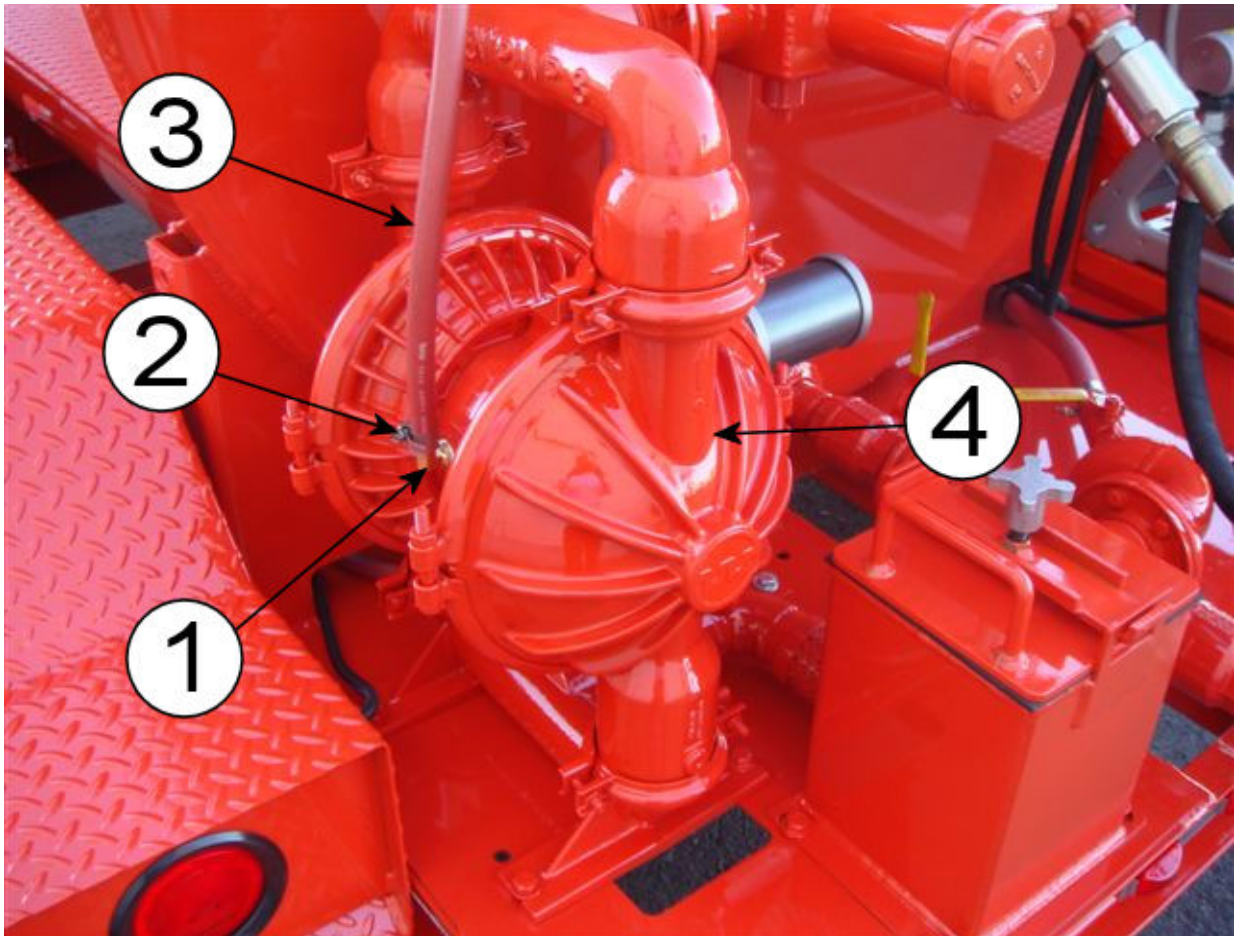


**Figure 8.23 Air System Regulator**

**Table 8-23 Air System Regulator**

FIG.	ITEM	PART NO.	DESCRIPTION	QTY.
Figure 8.23	1	70296	HOSE DUROFLEX ½ 300PS X 30" LONG	1
	2	70293	CLAMP, ½ X 29/32	1
	3	70292	BARB, ½ X ½ MPT 90 FITTING	1
	4	29214	½" BALL VALVE	1
	5	28003	½" CLOSE NIPPLE	1
	6	70241	½" AIR REGULATOR & FILTER	1
	7	70294	HOSE DUROFLEX ½ 300PS X 154" LONG	1
	8	70242	½" AIR PRESSURE GAUGE	1

**Chapter 8 Illustrated Parts List**



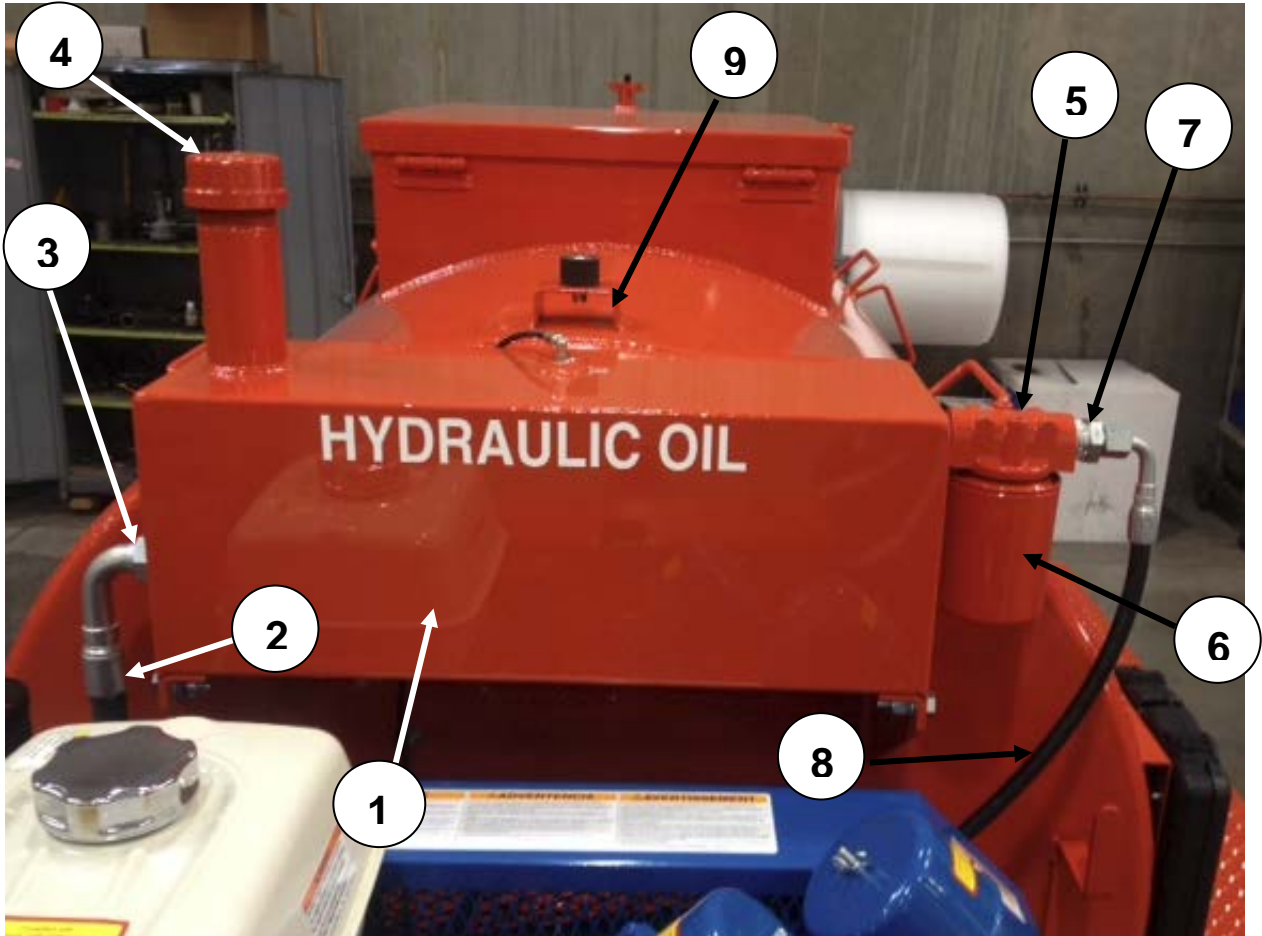
**Figure 8.24 Air System Diaphragm Pump**

**Table 8-24 Air System Regulator**

FIG.	ITEM	PART NO.	DESCRIPTION	QTY.
Figure 8.24	1	70295	BARB, ½ X ½ MPT 90° FITTING	1
	2	70293	CLAMP, ½ X 29/32	1
	3	70296	HOSE DUROFLEX ½ 300PS X 30" LONG	1
	4	70167	2" AIR DIAPHRAGM PUMP	1

**Chapter 8 Illustrated Parts List**

**8.17 Hydraulic System**



**Figure 8.25 Hydraulic Tank**

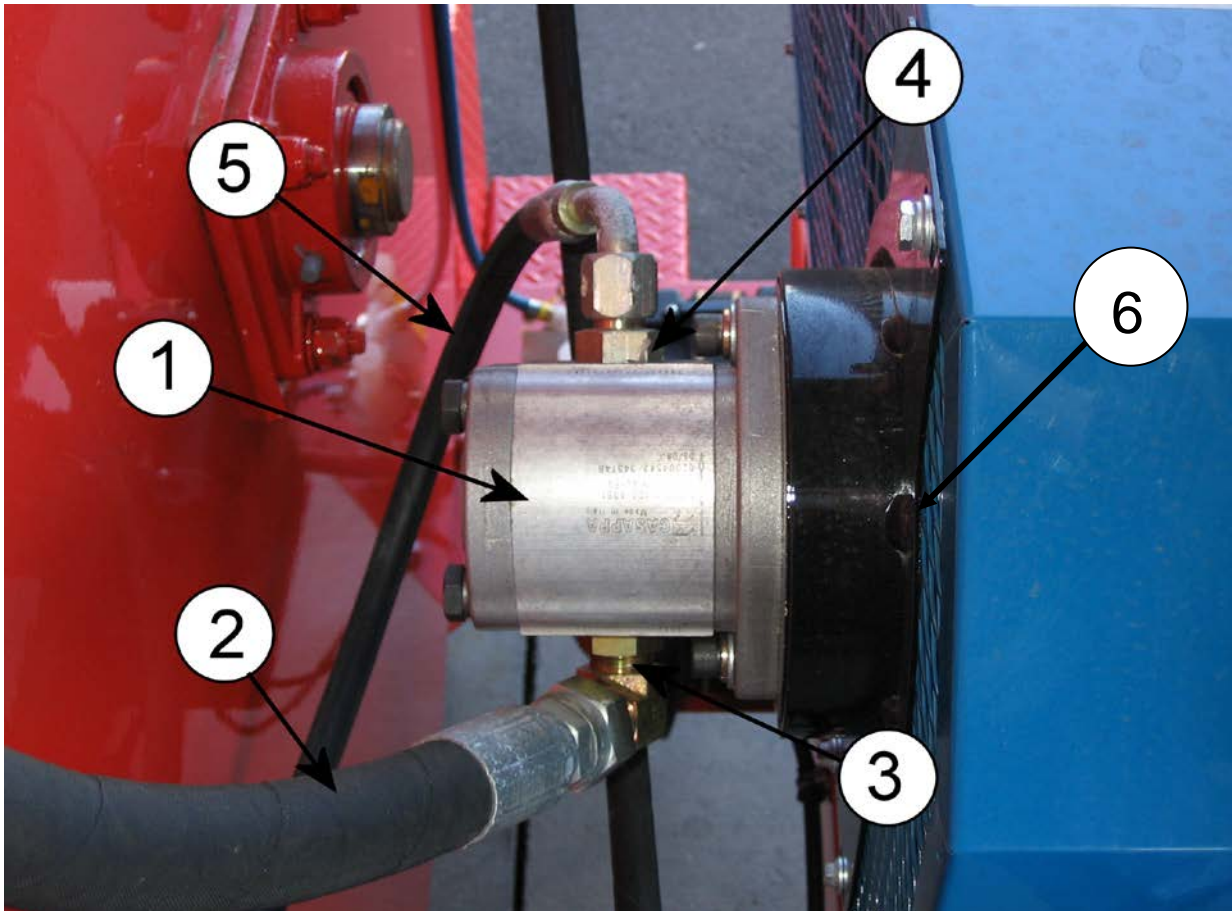


## Chapter 8 Illustrated Parts List

**Table 8-25 Hydraulic Tank**

FIG.	ITEM	PART NO.	DESCRIPTION	QTY.
Figure 8.25	1	70100	HYDRAULIC OIL TANK ASSEMBLY	1
	2	C12-16FJ9-12FJ-17 (550 GAL) C12-16FJ9-12FJ-24 (800 GAL)	HYDRAULIC HOSE ASSEMBLY (TANK TO PUMP)	1
	3	29818	SAE O-RING 1 ¼" X 1" JIC ADAPTER	1
	4	28273	CAP, 2" PIPE	1
	5	22070	HYD. FILTER W/ MOUNTING BASE ASSY.	1
	6	22071	HYD. FILTER ELEMENT	1
	7	40317	1" NPT X ½" JIC FITTING	1
	8	AX6-8FJ9-6FJ-54 (550 GAL) AX6-8FJ9-6FJ-60 (800 GAL)	HYDRAULIC HOSE ASSEMBLY (VALVE TO TANK)	1
	9	60233	¼" 90 PLASTIC TUBE FITTING	1
	10	70106	HYD. OIL BREATHER TUBE	1

**Chapter 8 Illustrated Parts List**

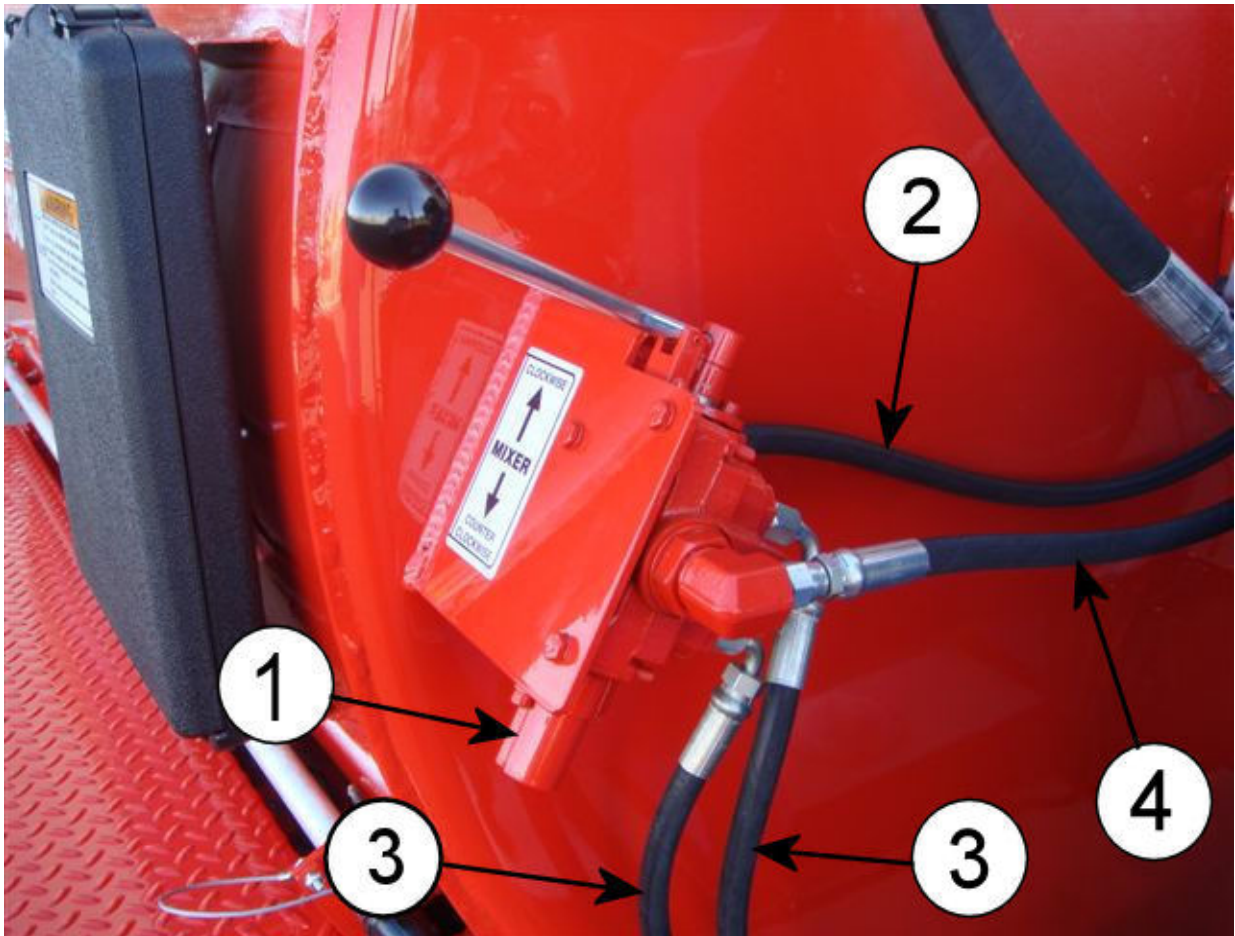


**Figure 8.26 Hydraulic Pump With Cover**

**Table 8-26 Hydraulic Tank**

FIG.	ITEM	PART NO.	DESCRIPTION	QTY.
Figure 8.26	1	70220	HYDRAULIC PUMP	1
	2	C12-16FJ9-12FJ-17 (550 GAL) C12-16FJ9-12FJ-24 (800 GAL)	HYDRAULIC HOSE ASSEMBLY (TANK TO PUMP)	1
	3	29934	3/4" JIC TUBE X 5/8" O-RING ADAPTER	1
	4	29913	5/8" O-RING X 1/2" JIC ADAPTER	1
	5	AX6-8FJ9-6FJ-19 (550 GAL) AX6-8FJ9-6FJ-32 (800 GAL)	HYDRAULIC HOSE ASSEMBLY (PUMP TO VALVE)	1
	6	70262	HYDRAULIC PUMP GUARD	1

**Chapter 8 Illustrated Parts List**

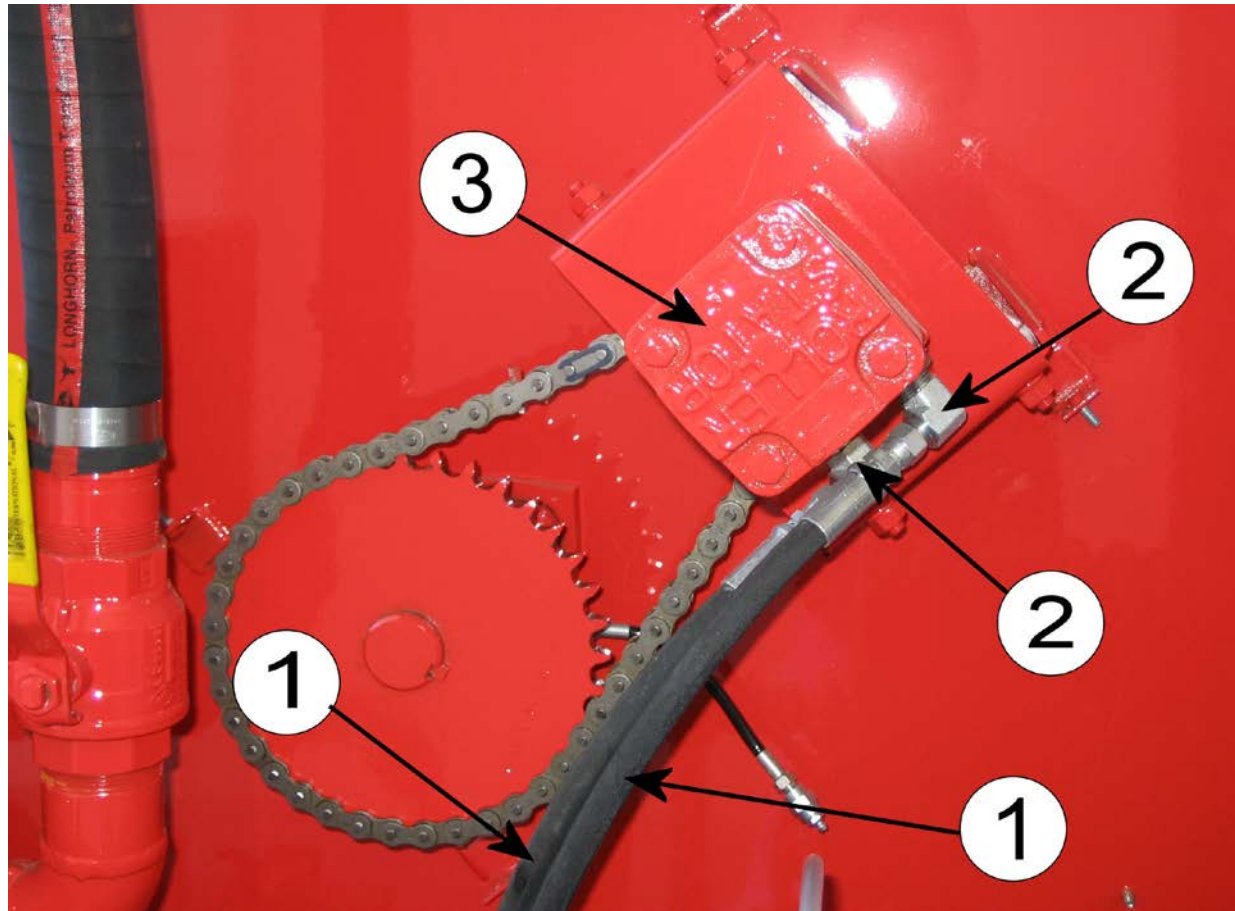


**Figure 8.27 Hydraulic Control and Hoses**

**Table 8-27 Hydraulic Control and Hoses**

FIG.	ITEM	PART NO.	DESCRIPTION	QTY.
Figure 8.27	1	41093	HYDRAULIC VALVE	1
	2	AX6-8FJ9-6FJ-19 (550 GAL) AX6-8FJ9-6FJ-32 (800 GAL)	HYDRAULIC HOSE ASSEMBLY (PUMP TO VALVE)	1
	3	AX6-6FJ-6FJ9-143 (550 GAL) AX6-6FJ-6FJ9-146 (800 GAL)	HYDRAULIC HOSE ASSEMBLY (VALVE TO MOTOR)	2
	4	AX6-8FJ9-6FJ-54 (550 GAL) AX6-8FJ9-6FJ-60 (800 GAL)	HYDRAULIC HOSE ASSEMBLY (VALVE TO TANK)	1

**Chapter 8 Illustrated Parts List**



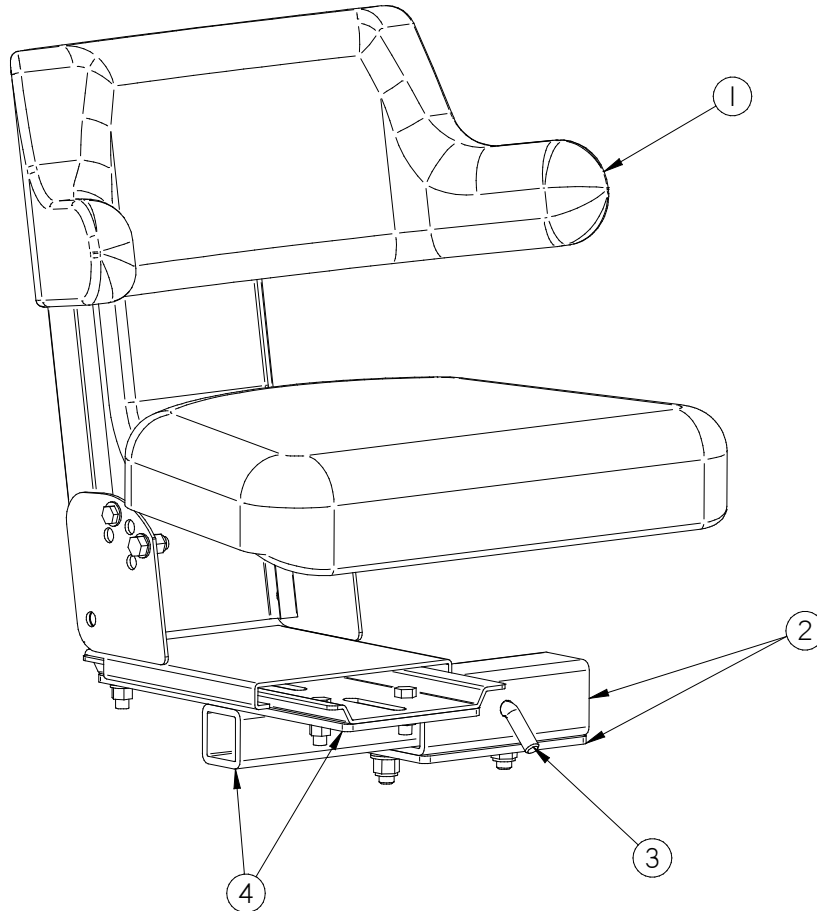
**Figure 8.28 Agitator Drive Hydraulics**

**Table 8-28 Hydraulic Control and Hoses**

FIG.	ITEM	PART NO.	DESCRIPTION	QTY.
Figure 8.28	1	AX6-6FJ-6FJ9-143 (550 GAL) AX6-6FJ-6FJ9-146 (800 GAL)	HYDRAULIC HOSE ASSEMBLY (VALVE TO MOTOR)	1
	2	29828	90 BOSS ADAPTER	2
	3	45428	HYDRAULIC MOTOR	1

**Chapter 8 Illustrated Parts List**

**8.18 Optional Operator Seat**



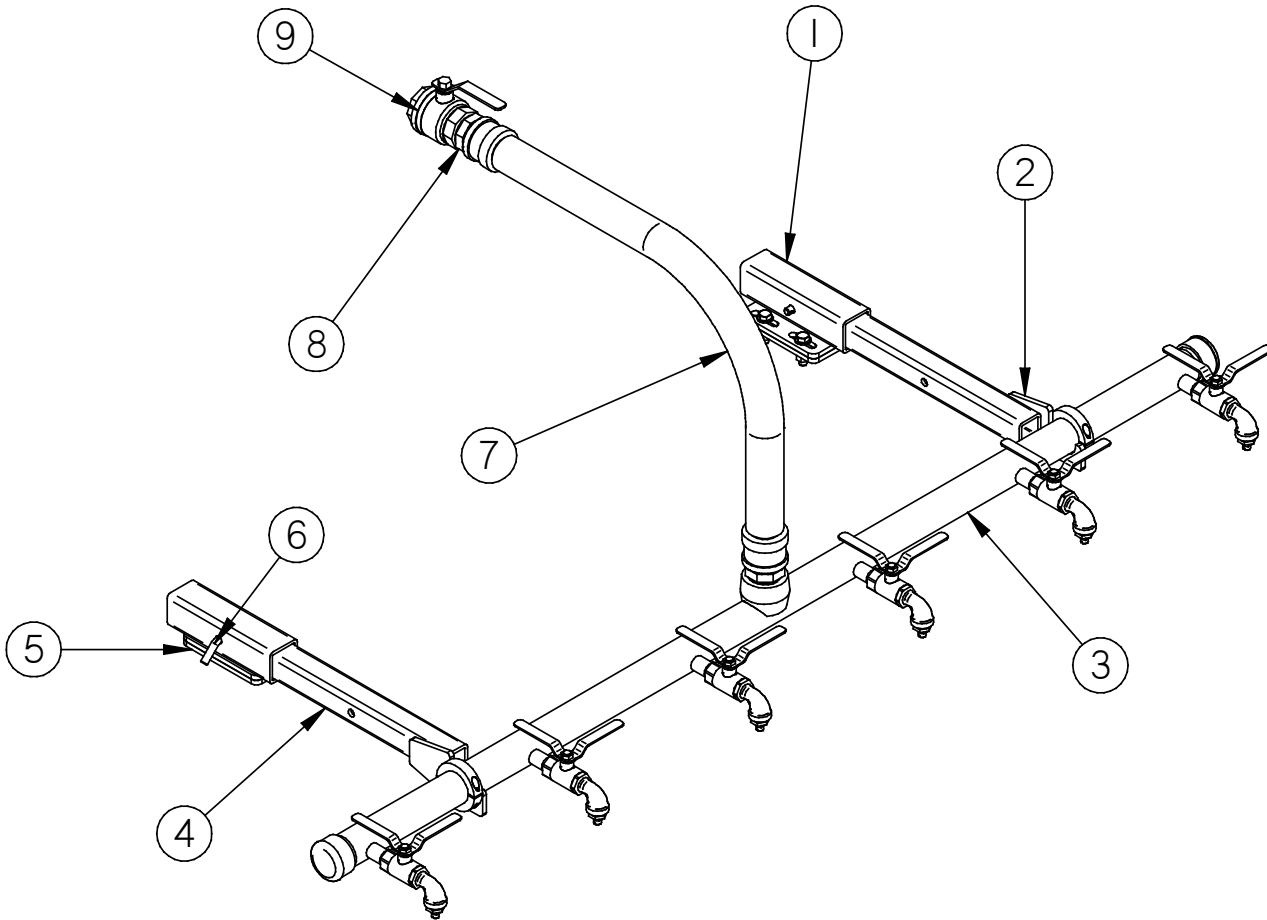
**Figure 8.29 Optional Operator Seat**

**Table 8-29 Optional Operator Seat**

FIG.	ITEM	PART NO.	DESCRIPTION	QTY.
Figure 8.29	1	70361	OPERATOR SEAT	1
	2	70354	SEAT BASE ASEMBLY	1
	3	42262	1/2" BENT HITCH PIN	1
	4	70357	SEAT MOUNT ASSEMBLY	1
	5	70362	SEAT BELT (NOT SHOWN)	1

**Chapter 8 Illustrated Parts List**

**8.19 Optional Manual Spray Bar Kit PN 70330K**



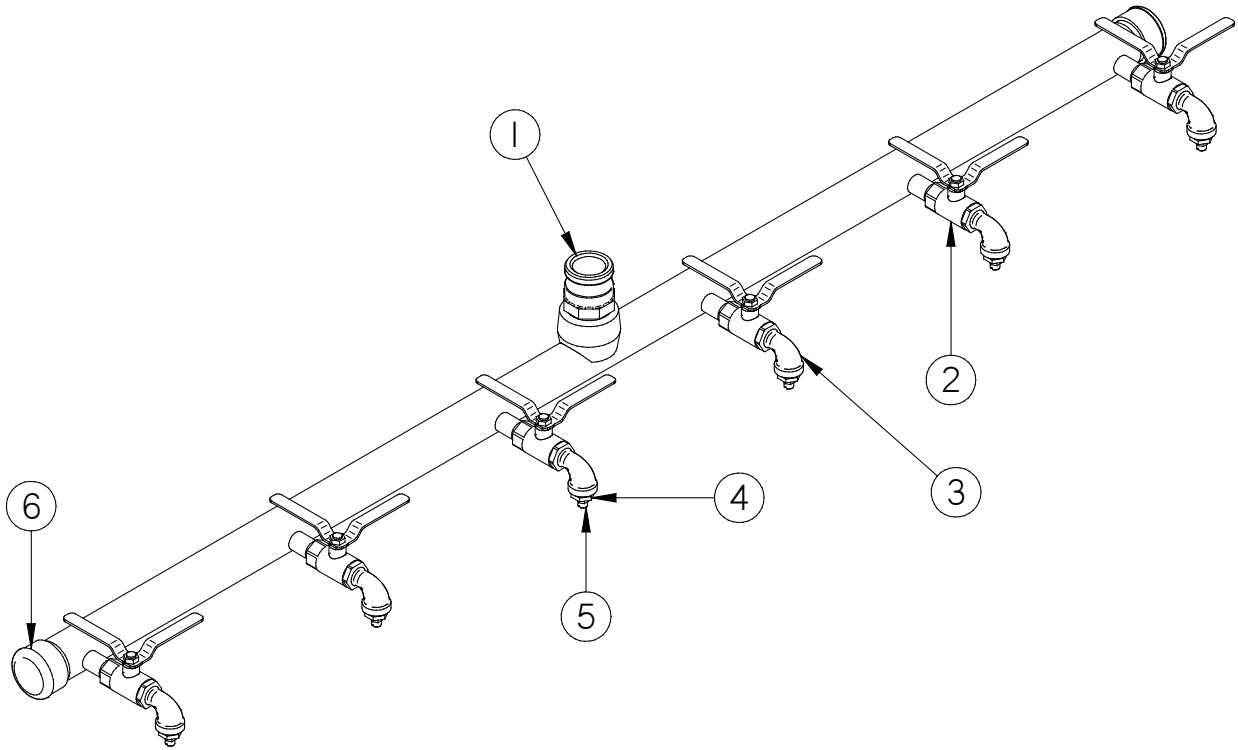
**Figure 8.30 Manual Spray Bar Kit PN 70330K**

**Table 8-30 Optional Spray Bar Kit PN 70330K**

FIG.	ITEM	PART NO.	DESCRIPTION	QTY.
Figure 8.30	1	70345	SPRAY BAR RECIEVER ASSEMBLY	2
	2	70378	SUPPORT RAIL ASSEMBLY – PASSENGERSIDE	1
	3	70330	MANUAL SPRAY BAR ASSEMBLY	1
	4	70377	SUPPORT RAIL ASSEMBLY – DRIVERSIDE	1
	5	70347	SPRAY BAR – RECIEVER MOUNTING PLATE	2
	6	42262	1/2" BENT HITCH PIN	2
	7	70349	SPRAY BAR MATERIAL HOSE	1
	8	70253	2" CAM LOCK X MALE THREADED FITTING	1
	9	70327	2" BALL VALVE – LOW TEMP.	1

**Chapter 8 Illustrated Parts List**

**8.19.1 Manual Spray Bar Assembly PN 70330**



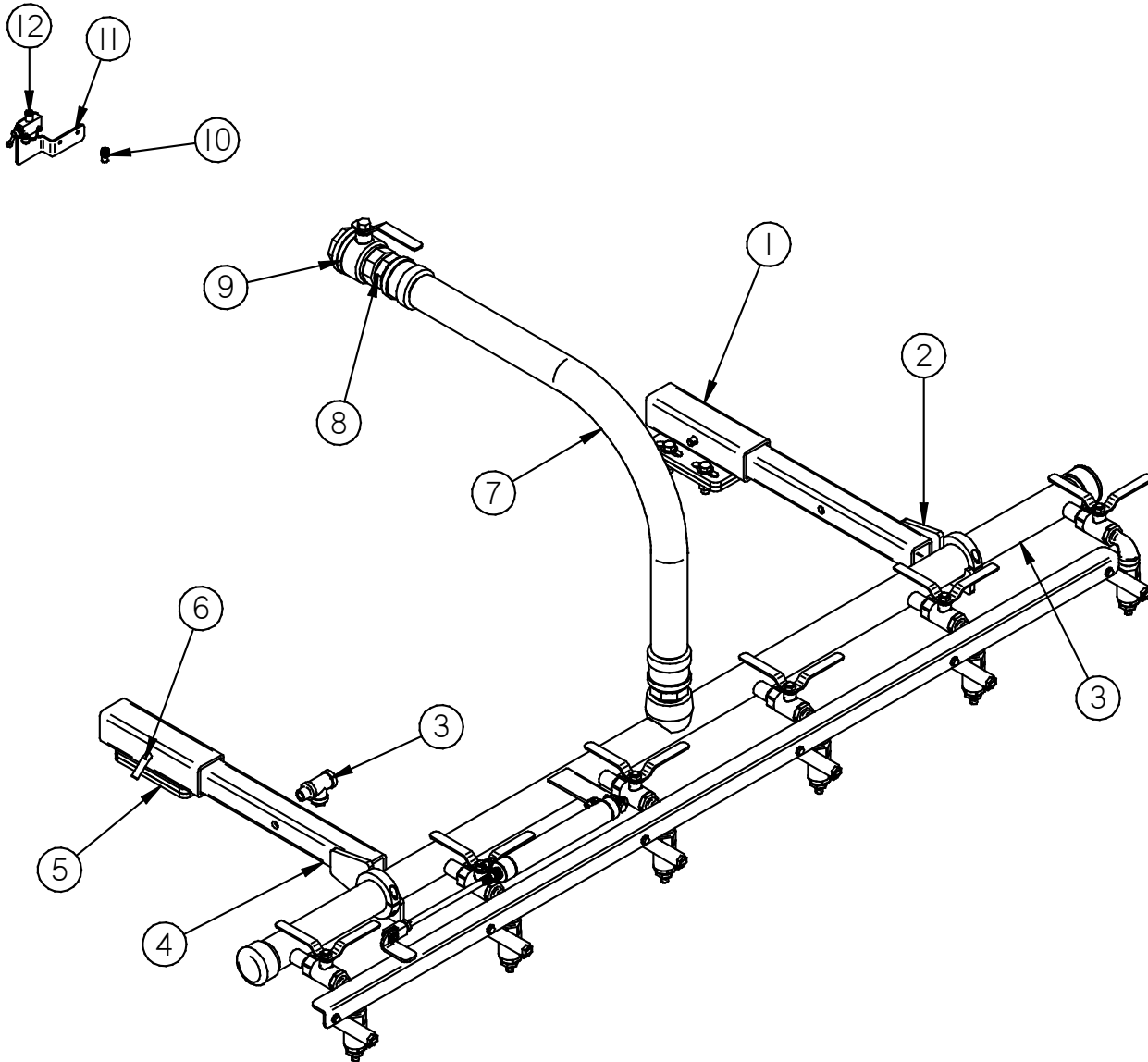
**Figure 8.31 Manual Spray Bar Assembly PN 70330**

**Table 8-31 Optional Spray Bar Assembly PN 70330**

FIG.	ITEM	PART NO.	DESCRIPTION	QTY.
Figure 8.31	1	70253	2" CAM LOCK X MALE THREADED FITTING	1
	2	29227	BRONZE BALL VALE 3/4"	6
	3	28239	3/4" ELBOW	6
	4	28346	BUSHING, 3/4" X 1/4"	6
	5	70268	FLAT SPRAY NOZZLE 80/50	6
	6	28273	2" PIPE CAP	2

**Chapter 8 Illustrated Parts List**

**8.20 Optional Automated Spray Bar Kit PN 70331K**



**Figure 8.32 Automated Spray Bar Kit PN 70331K**



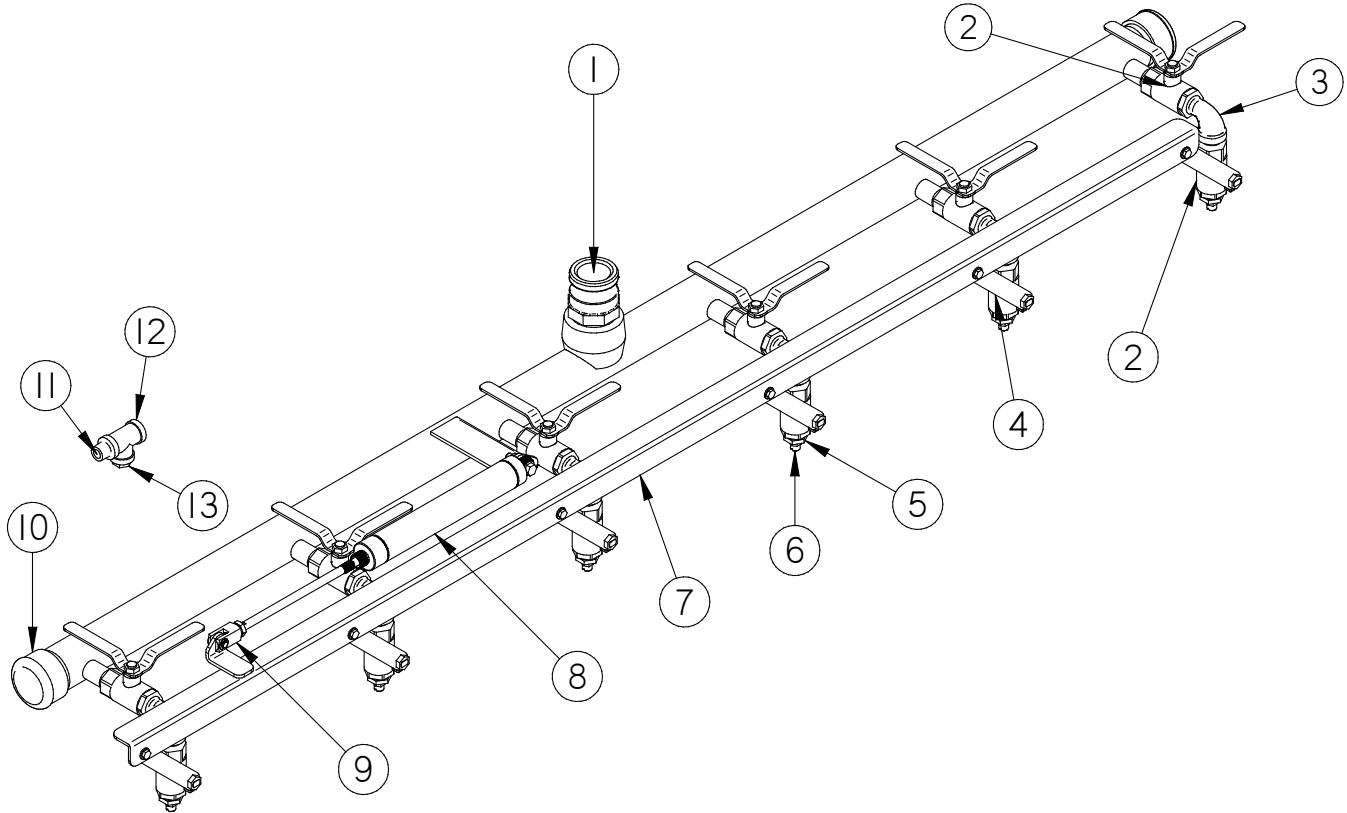
## Chapter 8 Illustrated Parts List

**Table 8-32 Optional Automated Spray Bar Kit PN 70331K**

FIG.	ITEM	PART NO.	DESCRIPTION	QTY.
Figure 8.32	1	70345	SPRAY BAR RECIEVER ASSEMBLY	2
	2	70378	SUPPORT RAIL ASSEMBLY – PASSENGERSIDE	1
	3	70331	AUTOMATED SPRAY BAR ASSEMBLY	1
	4	70377	SUPPORT RAIL ASSEMBLY – DRIVERSIDE	1
	5	70347	SPRAY BAR – RECIEVER MOUNTING PLATE	2
	6	42262	1/2" BENT HITCH PIN	2
	7	70349	SPRAY BAR MATERIAL HOSE	1
	8	70253	2" CAM LOCK X MALE THREADED FITTING	1
	9	70327	2" BALL VALVE – LOW TEMP.	1
	10	70363	1/4" TUBE X 1/8" NPT STRAIGHT FITTING	1
	11	70365	AIR SWITCH BRACKET	1
	12	70351	SPRAY BAR TOGGLE SWITCH	1

## Chapter 8 Illustrated Parts List

### 8.20.1 Automated Spray Bar Assembly PN 70331



**Figure 8.33 Automated Spray Bar PN 70331**

## Chapter 8 Illustrated Parts List

**Table 8-33 Automated Spray Bar PN 70331**

FIG.	ITEM	PART NO.	DESCRIPTION	QTY.
Figure 8.33	1	70253	2" CAM LOCK X MALE THREADED FITTING	1
	2	29227	BRONZE BALL VALE 3/4"	12
	3	28239	3/4" ELBOW	6
	4	70341	AUTOMATED SPRAY BAR VALVE HANDLE	6
	5	28346	BUSHING, 3/4" X 1/4"	6
	6	70268	FLAT SPRAY NOZZLE 80/50	6
	7	70342	AUTOMATED SPRAY BAR VALVE BAR	1
	8	70338	AIR CYLINDER, 1-1/2" BORE X 8" STROKE	1
	9	70339	AIR CYLINDER ROD CLEVIS W/ PIN	1
	10	28273	2" PIPE CAP	2
	11	28003	1/2" CLOSED NIPPLE	1
	12	28253	1/2 NPT TEE	1
	13	28343	1/2" X 1/8" BUSHING, GALVANIZED	1



**Chapter 9 Tools and Accessories**

**9.0 Tools and Accessories**



**Crafcoco Applicator Disk**  
27162 – 3" Disk Assembly  
27163 – 4" Disk Assembly  
27164 – 6" Disk Assembly



**Crafcoco Sealing Foot/Protruded**  
27159 – 1/4" Protruding  
27160 – 3/8" Protruding



**Crafcoco Joint Sealing Tip**  
27146 – 1/4" Sealing Tip  
27147 – 3/8" Sealing Tip



**Crafcoco Swivel Disk Applicator**  
27120 – 3" Swivel Applicator  
27130 – 4" Swivel Applicator



**Crafcoco Round Sealing Tip**  
27170 – 3/8" Sealing Tip  
27171 – 1/2" Sealing Tip



**Crafcoco Sealing Foot/Flush**  
27154 – 1/4" Flush  
27155 – 3/8" Flush

**Chapter 9 Tools and Accessories**



**Crafco Heavy Duty Squeegee with Aluminum Handle - 27199**  
27195 – Replacement Blade



**Crafco Pour Pot with Wheels - 40200**



**Super Shot Drip Stopper**  
Use with 50270 Duckbill  
27114 – Tip Adapter  
27115 – Shroud, Tip Adapter



**Crafco Hand Held Pour Pot - 40201**

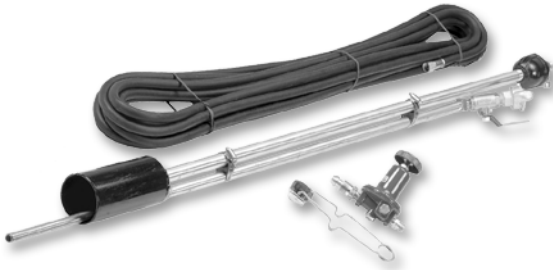


**Crafco Duckbill - 50270**



**Crafco High Velocity Heat Lance - 45650**

**Chapter 9 Tools and Accessories**



**Crafco Low Velocity Heat  
Lance - 32259**



**Crafco Hand Torch  
W/ 20ft. Hose – 25012  
W/ 12ft. Hose – 25016  
W/ 50ft. Hose - 25021**









©2019 Crafco, Inc.